

2014/2015 COMMERCIAL PRODUCTS CATALOG



BALL VALVES

BUTTERFLY VALVES

PRESSURE RELIEF VALVES

BACKFLOW PREVENTERS

GATE, GLOBE & CHECK VALVES

PRESSURE REDUCING VALVES

PIPELINE STRAINERS

WATER GAUGES

PLUMBING/HEATING SPECIALTIES

APOLLOXPRESS®



American Made Quality since 1928





A history of Quality, Service and Innovation

Now in its ninth decade, Conbraco Industries, Inc. is a leading manufacturer of flow control products for U.S. and international markets. The company's headquarters is based in Matthews, North Carolina with manufacturing plants and foundries located in Pageland and Conway, South Carolina.

Conbraco has a history of new product development and innovation that dates back to the company's inception in 1928. Today, the Conbraco line of products is marketed under the "Apollo Valves" brand and includes: ball valves, butterfly valves, backflow prevention devices, water pressure reducing valves, mixing valves, safety relief valves, water gauges, strainers, actuation and APOLLOXPRESS® products.

Conbraco's vertically integrated manufacturing ensures a consistency of production, testing, quality and availability. You can be assured that Conbraco flow control products will deliver long term reliability. All manufacturing facilities are ISO 9001:2008 certified.

The Conbraco line continues to expand with new products, designs and advanced materials to better serve the needs of our customers. Markets served include: chemical processing, pulp and paper, petroleum, residential and commercial plumbing and heating, OEM, irrigation, water works, and fire protection.



PAGELAND, SC
Bronze Foundry and Manufacturing Plant



PAGELAND, SC
Final Assembly and Distribution Center



CONWAY, SC
Steel Foundry and Manufacturing Plant



MATTHEWS, NC
Corporate Headquarters

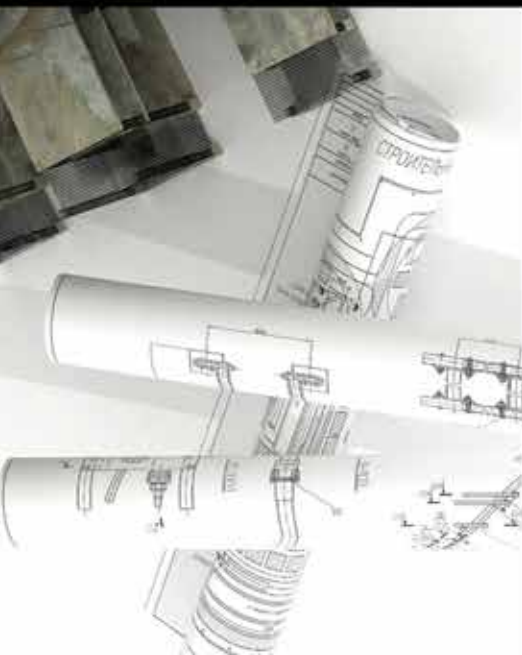

3D CAD DRAWINGS

available formats:
dwg, par, rfa, pdf & sat

Drawings also available for **LEAD FREE** models.

See page 6 for more information on Autodesk Seek.

Throughout this catalog, products that have a Lead Free* option will be identified with this logo.



* **LEAD FREE:** The wetted surfaces of this product shall contain no more than 0.25% lead by weighted average. Complies with Federal Public Law 111-380. ANSI 3rd party approved and listed.

Conbraco Industries offers a wide range of Apollo® products for potable and non-potable applications. When the use of lead free valves is required by code, specification or legislation, it is the sole responsibility of our customers to ensure that only lead free Apollo® products are installed in systems intended for potable water service. Further information related to our product offering and the **U.S. Safe Drinking Water Act (SDWA)** is available at www.apollovalves.com/lead_free, or by contacting Conbraco Customer Service.

** Any imported products are clearly identified as "Apollo International™".

COMMERCIAL PRODUCTS CATALOG

Table of Contents

Introduction	Page 2
Lead Free Products	7
New Products	9-12
APOLLOXPRESS®	13-14
Ball Valves	15-54
Butterfly Valves	55-62
Actuation	63-68
Safety & Relief Valves	69-90
Hydronic & Steam Heating	91-98
Mixing Valves	99-108
Water Pressure Reducing Valves	109-118
Backflow Preventers	119-134
Gate, Globe & Checks	135-152
Strainers	153-158
Water Gauges	159-168
Plumbing Specialties	169-181
Warranty Information & Terms and Conditions	182-183

Table of Contents by Series No.

Series No.	Model No.	Page No.	Series No.	Model No.	Page No.	Series No.	Model No.	Page No.
4A-100	DC4A	121	6WC	910WE	149	24-300		166
4ALF-100	DC4A	121	7K-100		43	24-600		166
4ALF-100(LBF)	DC4A	122	7K-SV		43	25-600		167
4A-200	RP4A	124	9A-100		50	26-100	CG	171
4ALF-200(LBF)	RP4A	125	10	RVW10	71	26-300	CGH	171
4A-500	PVB-4A	127	10-322	RV32	72	26-500	CGH	171
4ALF-200	RP4ALF	124	10-512	RVS52	72	27-200	RAV	93
4ALF-600	DCDA-4A	123	10-600	RVW60/61	73	27-400	SGS	172
4ALF-700	RPDA-4A	126	12-200	RVS12	74	29		84
4AnLF-100	DC-4An	122	13	RVS13	74	30	101S	137
4AnLF-200	RP-4An	125	14-200	RVS14	72	30LF	101S	137
4AnLF-600	DCDA-4An	123	14-400	RVA14	75	30	101T	137
4AnLF-700	RPDA-4An	126	14-500	RVA15	75	30LF	101T	137
4C-100	CBBP	130	14-600	RVV14	76	30	102S	137
4FP3	DUC-4FP	129	15-100	RVA15	77	30LF	102S	137
4NLF-300	DUC-4N	129	16-200	RVW16	78	30	102T-K	138
4SGLF	DC-4SG	122	16-500	RVW16A	78	30	102T	138
4SGLF-600	DCDA-4SG	122	16XT	EXT	93	30LF	102T	138
4W-500	SVB-4W	128	17-400	RVW17	79	30	103T	138
4WLF-500	SVB-4W	128	18C-400	TP	80	30	106T	139
6GA	610F	140	18C-402X	TPX	80	30	107T	139
6GA	611F	141	18C-500	TPC	81	30	111T	139
6GA	620F	140	19		82-83	30	116T	139
6GA	621F	141	20-100		161	31-200	BD90	180
6GB	711F	144	20LF-100		161	31-400	BDT	180
6GB	721F	144	20-200		161	31-500	BD90	180
6P	IBV-125	51	20-300		162	31-600	BD	181
6PLF	IBV-125	51	20-410		163	31-700	BD	181
6Q	IBVE-125	52	20-600/800		163	32-100		27
6SC	910F	147	20-700/710		164	32-200		28
6SC	910FLW	148	21		164	33	120S	142
6SC	920F	148	23-400		165	33LF	120S	142
6WC	910WB	149	23-600		165	33	120T	142



For additional information, submittal sheets and manuals, visit www.apollovalves.com

Customer Service (704) 841-6000

COMMERCIAL PRODUCTS CATALOG

Table of Contents by Series No.

Series No.	Model No.	Page No.	Series No.	Model No.	Page No.	Series No.	Model No.	Page No.
33LF	120T	142	61-100	CVB	150	78-124/125		53
33	121T	142	61LF-100	CVB	150	78-130		41
33LF	121T	142	61-200	CVB	150	78-256		39
33	122T	143	61LF-200	CVB	150	78-260/290		40
33	127T	143	61-500	CVBE	151	78-274-01		40
33	128T	143	61LF-500	CVBE	151	78-275-01		40
34ALF	MVA	102	61-600	CVBES	152	78-600	PBS	96
34B	MVB	104	61-700	CV	152	78-620		41
34BLF	MVB	104	61Y	161S	145	78-660/962		42
34C	MVC	103	61YLF	161S	145	78-970-01		97
34D	MVD	103	61Y	161T	145	78-RV	EXV	97
34DLF	MVD	103	61YLF	161T	145	78LF-RV	EXV	97
34ELF	MVE	107	61Y	162T	145	79-700		42
34HL	MVHL	105-106	61Y	163S	146	80-100		35
34-200	TV	101	61YLF	163S	146	82-200/240		45
35	FF	93	61Y	163T	146	82LF-200/240		45
35-200	HB	180	61YLF	163T	146	82-200/240 F1		46
35-300	BD	181	61Y	164T	146	82-200/240 F3		46
35-403	FCT	94	61Y	168T	147	82-100		44
35-6A3	FFB	94	61Y	169T	147	82LF-100		44
35-6H3	FFB	94	62-100	CVS	151	82-200		44
35FC	FC	94	62-500	CVSE	151	82LF-200		44
36LF	PR	111	62LF-500	CVSE	151	90-100		35
36CLF	PRC	112	70-100-BC		150	94A		47
36ELF	PRE	113-114	70-100/200		19	94ALF-A		48
36HLF	PRH	115	70LF-100/200		20	94 MBV		50
37-200	VR	98	70-140-64		23	94XLF		49
38-100	AVB1	128	70-200		20	95ALF		49
38LF-100	AVB1	128	70-200-63		24	119		85-86
38-200	AVB2	128	70-300/400		24	125YF	125YF	158
38-300	HBV2	132	70-600		25	500		87-89
38-304	HBDUC	132	70-800		25	612	YSS	156
38-400	HBVAF2	132	70-900		26	612	YCS/YCSW	157
38-502	LFDUC	132	70-HC		27	A127		116-117
40-000	FPV	131	70B-140		23	AD/AS	AD/AS	65
40LF-000	FPV	131	71-100		28	AE	AE	66
40-200	TK3/TK5/TKF	133	71-500		29	AGD		134
40-200 BV		134	73A-100		29	Ball Valve OPTIONS		21-22
40-200-ST	ST1	133	75-100-41		30	DPE		90
40-200-T2S	RP-40S	124	76F-100-A		30	I-2733/2734		168
40-300	DUC-40	130	77F		38	LC149		60
40-400	DCAP	131	77FLF		38	LD/WD 141		57-59
40-XT	EXP	98	77-100		31	LD/WD 145		57-59
41		173-174	77-200		31	W-7793-00		117
42-100		175	77-200		32	W-8078-00	HCPG	117
43-100		175	77-900		32	YCT	YCT	157
44-100		175	77B-100		33			
50	GCB	176	77BLF-100		33			
50G	GB50/GB50A	54	77B-300		33			
51	GC	177	77BLF-300		33			
51G	GB10/15/16	52-53	77BLF-800		34			
52	GC2	177	77C-100/200		17			
53	GC3	178	77C-100-94		96			
54	GCA	178	77CLF-100/200		18			
55	GCR	179	77D		34			
56	GCP	179	77G-UL		34			
58	BAV	95	77V		36			
58A		95	77VLF		36			
58B		95	77W		37			
59	YB	155	77WLF		37			
59LF	YB	155	77W-HC		39			
59-300	YBS	156	77WLF-HC		39			
59LF-300	YBS	156	77X		38			
59V	YVB	156	78-114-01		41			

COMMERCIAL PRODUCTS CATALOG

Table of Contents by Model No.

Model No.	Series No.	Page No.	Model No.	Series No.	Page No.	Model No.	Series No.	Page No.
101S	30	137	CV	61-700	152	PRH	36HLF	115
101S	30LF	137	CVB	61-100	150	PVB-4A	4A-500	127
101T	30	137	CVB	61LF-100	150	RAV	27-200	93
101T	30LF	137	CVB	61-200	150	RP-40S	40-200-T2S	124
102S	30	137	CVB	61LF-200	150	RP-4An	4AnLF-200	125
102S	30LF	137	CVBE	61-500	151	RP4A	4A-200	124
102T	30	138	CVBE	61LF-500	151	RP4ALF	4ALF-200	124
102T	30LF	138	CVBES	61-600	152	RP4A	4ALF-200(LBF)	125
102T-K	30	138	CVS	62-100	151	RPDA-4A	4ALF-700	126
103T	30	138	CVSE	62-500	151	RPDA-4An	4AnLF-700	126
106T	30	139	CVSE	62LF-500	151	RV32/52	10-322	72
107T	30	139	DC-4An	4AnLF-100	122	RVA14	10-512	72
111T	30	139	DC-4SG	4SGLF	122	RVA14	14-400/500	75
116T	30	139	DC4A	4A-100	121	RVA15	15-100	77
120S	33LF	142	DC4A	4ALF-100	121	RVS12	12-200	74
120S	33	142	DC4A	4ALF-100(LBF)	122	RVS13	13	74
120T	33LF	142	DCAP	40-400	131	RVS14	14-200	72
120T	33	142	DCDA-4A	4ALF-600	122	RVS32	10-322	72
121T	33	142	DCDA-4An	4AnLF-600	122	RVS52	10-512	72
121T	33LF	142	DCDA-4SG	4SGLF-600	122	RVV14	14-600	76
122T	33	143	DUC-40	40-300	130	RVW10	10	71
125YF	125YF	158	DUC-4FP	4FP3	129	RVW16	16-200	78
127T	33	143	DUC-4N	4NLF-300	129	RVW16A	16-500	78
128T	33	143	EXP	40-XT	98	RVW17	17-400	79
161S	61Y	145	EXT	16XT	93	RVW60/61	10-600	73
161S	61YLF	145	EXV	78-RV	97	SGS	27-400	172
161T	61Y	145	EXV	78LF-RV	97	ST1	40-200-ST	133
161T	61YLF	145	FC	35FC	94	SVB-4W	4W-500	128
162T	61Y	145	FCT	35-403	94	SVB-4W	4WLF-500	128
163S	61Y	146	FF	35	93	TK3/TK5/TKF	40-200	133
163S	61YLF	146	FFB	35-6A3	94	TP	18C-400	80
163T	61Y	146	FFB	35-6H3	94	TPC	18C-500	81
163T	61YLF	146	FPV	40-000	131	TPX	18C-402X	80
164T	61Y	146	FPV	40LF-000	131	TV	34-200	101
168T	61Y	147	GB10/15/16	51G	52-53	VR	37-200	98
169T	61Y	147	GB50/GB50A	50G	54	YB	59	155
610F	6GA	140	GC	51	177	YB	59LF	155
611F	6GA	141	GC2	52	177	YBS	59-300	156
620F	6GA	140	GC3	53	178	YBS	59LF-300	156
621F	6GA	141	GCA	54	178	YCS/YCSW	612	157
711F	6GB	144	GCB	50	176	YCT	YCT	157
721F	6GB	144	GCP	56	179	YSS	612	156
910F	6SC	147	GCR	55	179	YVB	59V	156
910FLW	6SC	148	HB	35-200	180			
910WB	6WC	149	HBDUC	38-304	132			
910WE	6WC	149	HBV2	38-300	132			
920F	6SC	148	HBVAF2	38-400	132			
AD/AS	AD/AS	65	HCPG	W-8078-00	117			
AE	AE	66	IBV-125	6P	51			
AVB1	38-100	128	IBVE-125	6Q	51			
AVB1	38LF-100	128	LDUC	38-502	132			
AVB2	38-200	128	MVA	34ALF	102			
BAV	58	95	MVB	34B	104			
BD	31-600	181	MVB	34BLF	104			
BD	31-700	181	MVC	34C	103			
BD	35-300	181	MVD	34D	103			
BD90	31-200	180	MVD	34DLF	103			
BD90	31-500	180	MVE	34ELF	107			
BDT	31-400	180	MVHL	34HL	105-106			
CBBP	4C-100	130	PBS	78-600	96			
CG	26-100	171	PR	36LF	111			
CGH	26-300	171	PRC	36CLF	112			
CGH	26-500	171	PRE	36ELF	113-114			



For additional information, submittal sheets and manuals, visit www.apollovalves.com

Customer Service (704) 841-6000

The latest generation of 3D CAD Revit Models

for **valves** and **fittings**

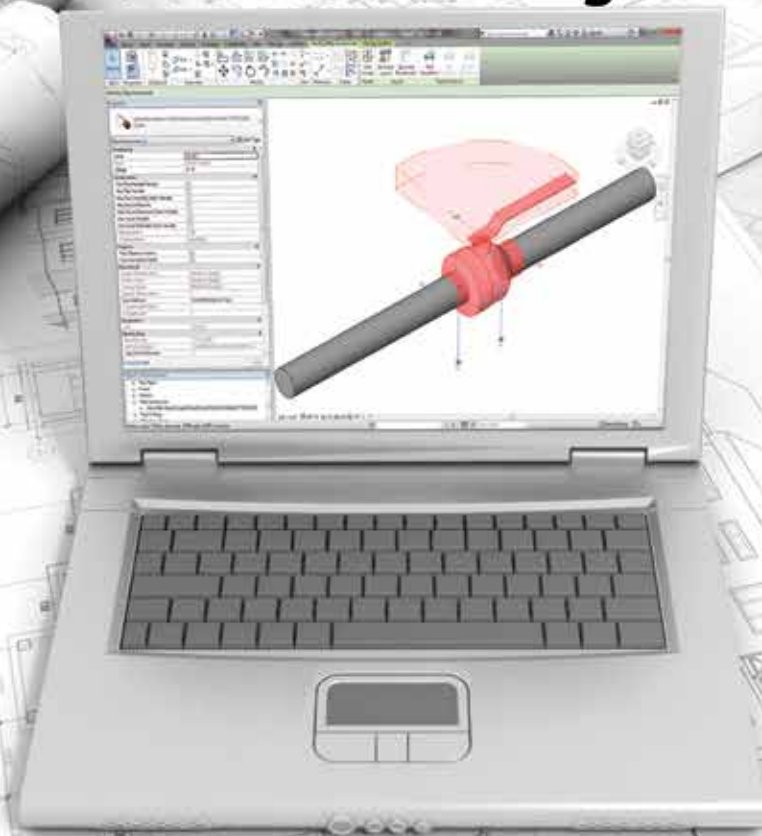

now available
@ seek.autodesk.com



AUTODESK®
SEEK

Featuring **Enhanced Functionality** for the Designer, Estimator and Fabricator:

- Conflict Checking
- In-drawing lever options
- Intelligent Pipe / Tube Connections



Elkhart Products
Corporation



Now Available

Ball Valves
Backflow Preventers
Pressure Reducing Valves
Mixing Valves
Gate, Globe & Check Valves
APOLLOXPRESS® Press Valves and Fittings
Wrot Copper and Kleenfit Fittings
and much more

APOLLO VALVES



(704) 841.6000



[apollovalves.com](https://www.apollovalves.com)

follow us   

ELKHART PRODUCTS



(800) 395.7313



[elkhartproducts.com](https://www.elkhartproducts.com)

follow us   



We have **solutions**
that make **lead free**
easy for you.

Our valves have always conformed to Federal and State lead level requirements. Now, as new lead reduction initiatives have taken effect, Apollo Valves is committed to providing our customers with a Lead Free* alternative for valves intended for potable water service. The same great Apollo products you know and trust, now with optional Lead Free materials and approvals. Choose American-made Apollo Valves.

Apollo® Valves has the products, experience and personnel to help you meet the new Lead Free laws.



Ball Valves | Mixing Valves | Strainers | Backflow Preventers | APOLLOXPRESS® | Pressure Reducing Valves | and more

For the latest Lead Free Information see our **Lead Free Catalog (LFCAT)** at
www.apollovalves.com



















Our Lead Free Products

Series	Size	Description	Connection	Series	Size	Description	Connection
30LF	1/4" - 3"	Bronze Gate Valve	NPT, Solder, Press	45G100	2-1/2" - 6"	Double Check Valve	Flanged, Grooved
33LF	1/4" - 2"	Bronze Globe Valve	NPT, Solder, Press	59LF	1/8" - 4"	Strainer, Bronze	NPT, Push, Press
34ALF	1/2" - 1"	Mixing Valve	NPT, Solder, PEX, CPVC	6PLF*	2" - 10"	Cast Iron Ball Valve	Flanged
34BLF	1/2" - 1"	Mixing Valve	NPT, Solder, PEX, CPVC	61LF100	1/4" - 3"	Check Valve, Bronze, Ball Cone	NPT, Push
34DLF	3/8"	Mixing Valve	Compression	61LF500	3/8" - 3/4"	Check valve, Bronze, Soft Seat	NPT
36LF	1/2" - 2"	Water Pressure Reducing Valve	NPT, Solder, PEX, CPVC	61YLF	1/4" - 2"	Swing Check, Bronze	NPT, Solder, Press
36CLF	1/2" - 1"	Water Pressure Reducing Valve	NPT, Solder, PEX, CPVC, Push, Press	70LF	1/4" - 4"	Ball Valve, Bronze	NPT & Solder
36ELF	1/2" - 2"	Water Pressure Reducing Valve	NPT, Solder, PEX, CPVC, Push, Press	70LF-HC	1/2" - 3/4"	Ball Valve, Bronze, Hose Cap & Chain	NPT & Solder
36HLF	1/2" - 3"	Water Pressure Reducing Valve	NPT, Flanged	76	1/4" - 3"	Ball Valve, SS Standard Port	NPT
38LF-100	1/4" - 2"	Atmospheric Vacuum Breaker	NPT	76F	1/2" - 2"	Ball Valve, SS Full Port	NPT
40LF-000	1/8"	Freeze Protection Valve	NPT	77CLF	1/4" - 2-1/2"	Ball Valve, Bronze	NPT & Solder
40LF-300	1/2" - 1"	Dual Check Valve	NPT, NPSM, BSPP	77FLF	1/4" - 4"	Ball Valve, Brass	NPT & Solder
40LF-400	1/2" - 3/4"	Dual Check with Atmospheric Port	NPT, Solder, BSPP	77VLF	1/2" - 4"	Ball Valve, Brass	Press ends
40XT	3/4"	Expansion Tanks, Potable	NPT	77WLF	1/2" - 2"	Ball Valve, Bronze	Press ends
4ALF-100	1/2" - 2"	Double Check Valve	NPT	77WLF-HC	1/2" - 3/4"	Ball Valve, Bronze, Hose Cap & Chain	Press end
4ALF-100	2 1/2" - 12"	Double Check Valve	Flanged, Grooved	78LF-RV	3/4"	Ball Valve, Thermal Expansion Relief	NPT, Solder, PEX, Push
4ALF-200	1/2" - 2"	Reduced Pressure Assembly	NPT	82LF	1/4" - 2-1/2"	Ball Valve, Bronze, 3 Piece	NPT, Solder / Brazed
4ALF-200	2-1/2" - 12"	Reduced Pressure Assembly	Flanged, Grooved	86A	1/4" - 2"	Ball Valve, SS 3 Piece 1500 CWP	NPT, SW, BW
4ANLF-100	2-1/2" - 12"	Double Check Valve	Flanged, Grooved	86B	1/4" - 2"	Ball Valve, SS 3 Piece Class 600	NPT, SW, BW
4ANLF-200	2-1/2" - 12"	Reduced Pressure Assembly	Flanged, Grooved	87A-200	1/2" - 4"	Ball Valve, SS ASME 150#	Flanged
4C100	1/4" - 3/8"	Carbonated Beverage Backflow Prev.	NPT & Flare	94ALF-A*	1/4" - 4"	Ball Valve, Brass	NPT & Solder
4FPLF300	1" - 1-1/4"	Residential F.P. Dual Check Valve	NPT & NPSM	94XLF*	1/2" - 1"	Ball Valve, Lead Free Brass	PEX
4NLF300	3/8" - 1"	Dual Check Valve	NPT, NPSM, BSPP	95ALF*	1/2" - 1"	Ball Valve, Brass, Stop and waste	NPT & Solder
				LD/WD 145	2" - 12"	Butterfly Valve	Lug or Wafer

* Apollo International

COMMERCIAL PRODUCTS CATALOG

Apollo Ball Valves Certification Key

<p>American Society of Mechanical Engineers Section I - Power Boilers</p>		<p>CSA International</p> 
<p>American Society of Mechanical Engineers Section VIII - Pressure Vessels</p>		<p>American Society of Sanitary Engineering</p> 
<p>American Society of Mechanical Engineers Section IV - Heating Boilers</p>		<p>National Sanitation Foundation</p> 
<p>National Board of Boiler & Pressure Vessel Inspectors</p>		<p>Underwriters Laboratory</p> 
<p>Factory Mutual</p>		<p>Uniform Plumbing Code</p> 
<p>Communauté Européenne/ Pressure Equipment Directive</p>		<p>International Association of Plumbing & Mechanical Officials</p> 
<p>American National Standards Institute</p>		<p>Truesdail Laboratories ANSI 3rd party testing agency</p> 
<p>Manufacturers Standardization Society</p>		<p>International Code Council</p> 



NEW PRODUCTS

NEW PRODUCTS

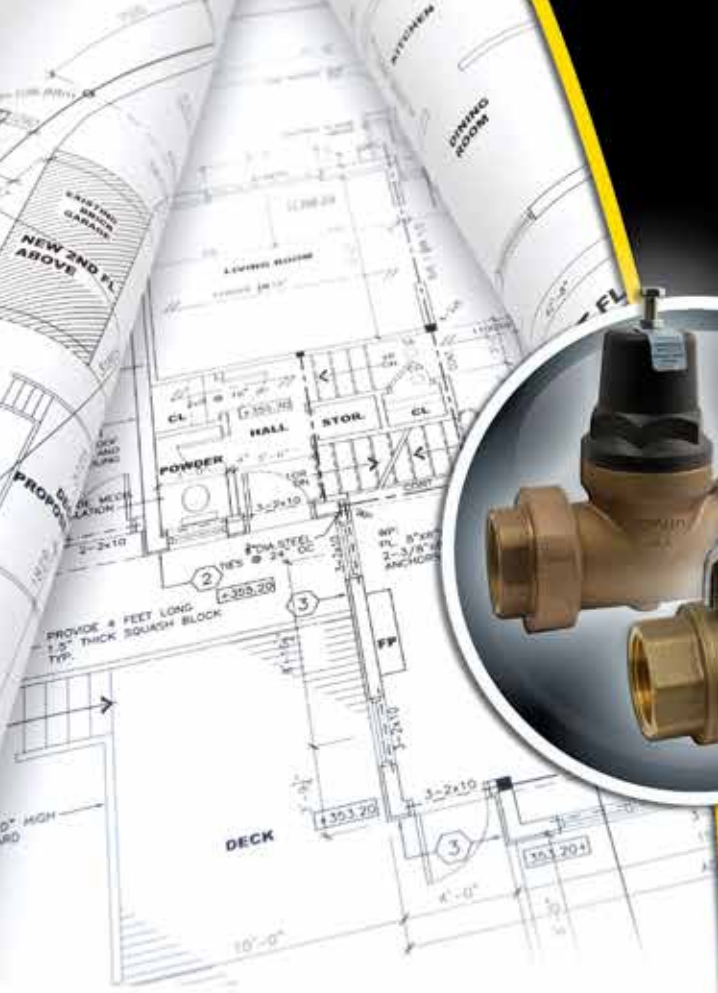

NEW PRODUCTS

Ball Valves

82LF SERIES

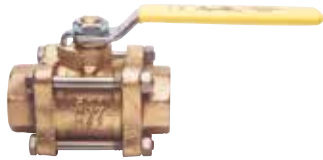

LEAD FREE - FULL PORT BRONZE THREE-PIECE SOLDER/BRAZED END VALVE

Valve features full port and is easily repaired inline. Apollo EZ-Solder™ lead free bronze is designed for soft soldering or brazed installation. Includes RPTFE seats and seals. Sizes 1/4" - 2-1/2".

See page 44 for more information.

77F/77FLF SERIES



FULL PORT BRASS BALL VALVE

The Apollo 77F Series is a full port forged brass ball valve suitable for a wide range of plumbing and heating applications. These 2-piece valves combine reliable operation with maximum economy. Available in NPT and Solder in Standard and Lead Free Brass. Valves include most pertinent agency approvals for fuels, gas and fire protection applications. Proudly Made in the USA. Sizes 1/4" - 4". See page 38 for more information.

94ALF-A SERIES



LEAD FREE - FULL PORT BRASS BALL VALVE

The Apollo® International 94ALF-A Lead Free forged brass ball valves combine reliable operation with maximum economy. Now with multi-agency approvals, the 94ALF-A is ideal for gas, fuels, fire protection and general plumbing and HVAC applications including potable water. Valves are ANSI 3rd party Lead Free certified. Sizes 1/4" - 4".

See page 48 for more information.

95ALF SERIES



LEAD FREE - FULL PORT BRASS BALL VALVE – STOP AND WASTE

The Apollo® International 95ALF Lead Free forged brass ball valves combine reliable operation with maximum economy. Ideal for plumbing or hydronic systems where draining is required. Valves are certified by IAPMO and ANSI 3rd party Lead Free certified. Sizes 1/2" - 1". See page 49 for more information.

77V/77VLF SERIES



APOLLOXPRESS®



APOLLOXPRESS® PRESS END BRASS BALL VALVE

The APOLLOXPRESS® 77V/77VLF Series two-piece press ball valve is ideal for installation in most plumbing and heating systems. Features Leak Before Press® technology and 250 psig maximum working pressure. Sizes 1/2" - 4". Proudly Made in the USA. See page 36 for more information.

94XLF SERIES



LEAD FREE - APOLLOPEX™ BALL VALVE

The Apollo® International 94XLF Lead Free* DZR forged brass ball valves with F1807 PEX connections combine reliable operation with maximum economy. Ideal for plumbing and heating applications including potable water. Valves are ANSI 3rd party Lead Free* certified and listed to NSF 14, NSF 61 and NSF 372 Lead Free. Sizes 1/2" - 1".

See page 49 for more information.

COMMERCIAL PRODUCTS CATALOG

Butterfly Valves

LD/WD 145 SERIES



WD 145 Wafer
2" - 12"



LD 145 Lug
2" - 12"

MADE IN AMERICA

The Apollo LD/WD Series ductile iron butterfly valves are ideal for use in industrial and HVAC/mechanical applications. The WD Series is a wafer style valve and the LD Series is a lug style.

FEATURES

- Sizes: 2" - 12"
- Compatible with ANSI 125# & 150# flanges
- ISO 5211 top plate allows choice of Apollo pneumatic actuators and manual operators
- Conforms to MSS SP-67 & API 609
- LD145 Series suitable for end of line service to rated pressure
- 3"-12" meet performance requirements of AWWA C-504
- NSF/ANSI 372 Lead Free

See page 57 for more information.

Water Pressure Reducing Valves

PRE (36ELF) SERIES



HIGH EFFICIENCY ECONOMY - RESIDENTIAL AND COMMERCIAL APPLICATIONS

The Apollo® 36ELF is designed to protect residential and commercial water supplies by automatically reducing elevated supply pressures. The streamlined dezincification resistant bronze body and dielectric polymer cage provide maximum corrosion resistance. Designed for easy in-line servicing with simple cartridge removal. **Now available in sizes 1/2" - 2". Proudly Made in the USA.** *See page 114 for more information.*

APOLLOPUSH™ VALVES

APOLLOPUSH™



APOLLOPUSH™ WATER PRESSURE REDUCING VALVE, STRAINERS & IN-LINE CHECK VALVES

The Apollo 36ELF Series, 59LF Series, and 61LF Series are now available with Apollo-Push direct connectors. Combining standard features with proven TECTITE push-fit technology. Features fast and simple "push to connect" installation. Suitable for use with copper, CPVC, and PEX tubing. Dezincification resistant bronze construction provides maximum corrosion resistance. Removable using optional demounting tool. Standard and Lead Free models available.

See our website for more information.

Apollo International™ Cast Iron Ball Valve

6PLF SERIES



CAST IRON CLASS 125 FLANGED BALL VALVE

The cast iron/epoxy coated, Class 125, 6PLF Series Lead Free Ball Valves offer unobstructed turbulence-free flow that gate and butterfly valves can't match. Compact design and low profile handle for easy installation in tight areas. Valves are NSF 61 approved and NSF 372 Lead Free, ANSI 3rd party approved and listed.

See page 52 for more information.



APOLLOXPRESS®

APOLLOXPRESS®

Your **Single Source Solution** for **Press Technology**

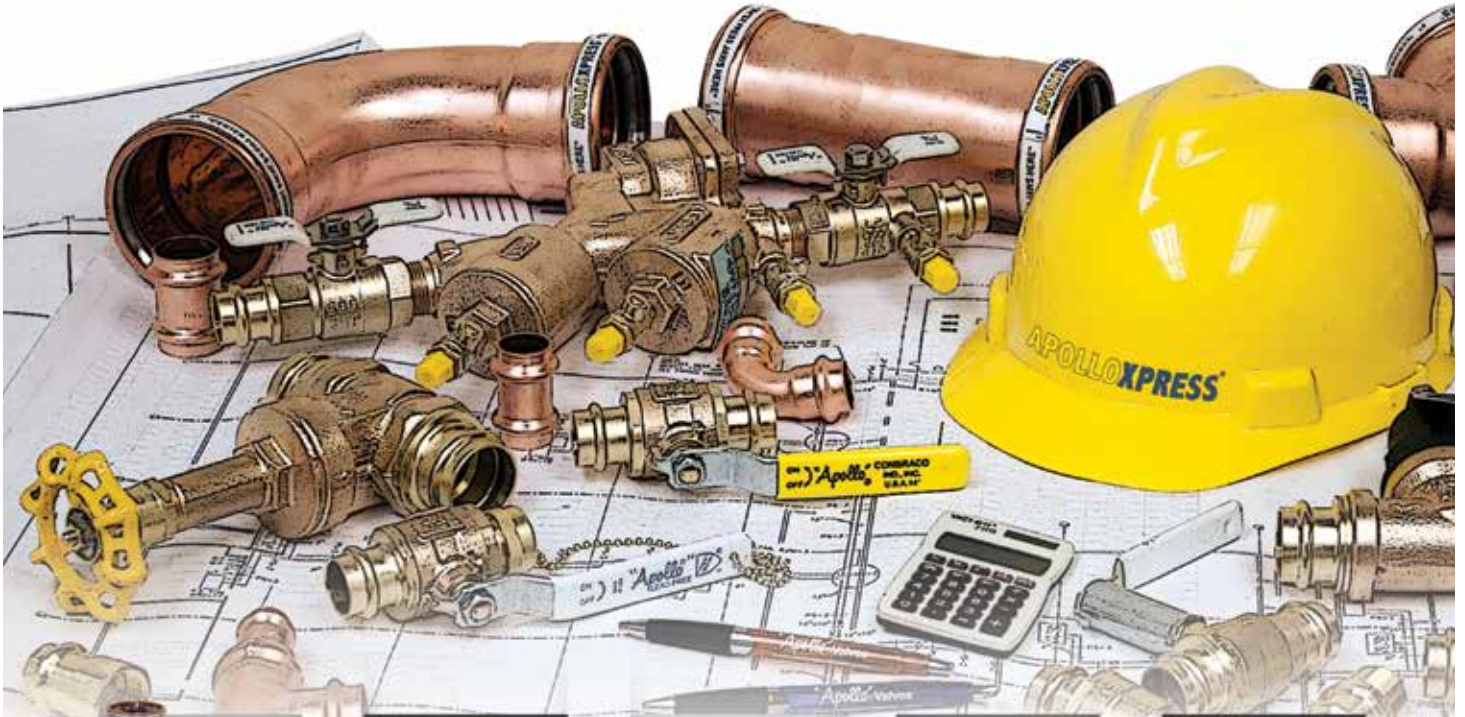

LARGE AND SMALL DIAMETER FITTINGS

Available in Sizes 1/2" to 4"



BALL VALVES

Available in Sizes 1/2" to 4"



GATE, GLOBE, CHECKS and STRAINERS

Available in Sizes 1/2" to 2"



WATER PRESSURE REDUCING VALVES

Available in Sizes 1/2" to 2"



BACKFLOW PREVENTION

Available in Sizes 1/2" to 2"

Features & BENEFITS

American Made **Quality** you can **Depend On**.

Mechanical **Leak Before Press®** on small diameter, within a 120 degree turn.

Deepest cup depth on the market.

Short turn elbows for space saving alternatives.

Radial orientation on installation is not necessary on the **APOLLOXPRESS®** line.

VISUAL and **Mechanical Leak Before Press®** feature on our large diameter fittings.

Patented stainless steel grab ring on large diameter 2 1/2" - 4"

Unique Floating flanges can be put back in place during installation.

One piece **welded construction tees**.

Custom Factory welded by **certified welders**.

Lighter construction.

Height reduction resulting in **smaller envelope**.

100% water tested weld or press.

BIM ready **3D CAD drawings** available.

Made in USA



Valves available in both **standard** and **Lead Free** models



See **APOLLOXPRESS®** Catalog (AXCAT) for more detailed information about **APOLLOXPRESS®** products.



BALL VALVES

COMMERCIAL PRODUCTS CATALOG

Apollo Ball Valve Numbering System

APOLLO NUMBERING SYSTEM FORMULA: 70 - 105 - 01

XX	-	X	X	X	- XX
SERIES		CONFIGURATION	VARIATIONS	SIZE*	OPTIONS
32		1 = FNPT	4 = 316 Stainless Steel	1 = 1/4"	-01 = Standard
50		2 = Solder	Ball & Stem	2 = 3/8"	-02 = Grounded
51		3 = Union End NPT	9 = Pinned Retainer	3 = 1/2"	-04 = 2-1/4" Stem extension
6P		4 = Union End Solder		4 = 3/4"	-05 = Plain Ball
NEW 6PLF		5 = Spring Return		5 = 1"	-07 = Tee Handle
		6 = 3-Way NPT		6 = 1-1/4"	-08 = 90° Reversed Stem
6Q		7 = Full-Port Refrigeration Valves		7 = 1-1/2"	-10 = Stainless Steel Lever & Nut
		8 = Male X FNPT		8 = 2"	-11 = Therma-Seal™ Insulating Handle
64		9 = 3-Way Solder		9 = 2-1/2"	-12 = Stamped "157 SWP" & Bagged
70				A = 4"	-13 = Stamped "157 SWP"
70LF					-14 = Side Vented Ball (uni-directional)
71					-15 = Round Handle, Steel
75					-16 = Chain Lever - Vertical
77					-17 = Rough Chrome Plated
77B					-18 = Plain Yellow Grip
77C					-19 = Lock Plate
77CLF					-20 = Slot Vented Ball (bi-directional)
77D					-21 = UHMWPE Trim (non-PTFE)
NEW 77F					-24 = Graphite Packing
77FLF					-27 = Stainless Steel Latch-Lock Lever & Nut
77V					-30 = Cam-Lock and Grounded
77VLF					-31 = 77B Series w/Boss NOT Drilled/Tapped
77W					-32 = Stainless Steel Tee Handle & Nut
77WLF					-35 = VTFE Trim (PTFE)
78					-36 = Stainless Steel Hi-Rise Round Handle, Stainless Steel Nut
79					-39 = SS Hi-rise Locking Round Handle, SS Nut
77B					-40 = Cyl-Loc and Grounded
7K					-41 = Automatic Drain
80					-45 = Less Lever and Nut
82					-46 = Latch-Lock Lever - Lock in Closed Position Only
82LF					-47 = SS Oval Latch-Lock Handle & Nut
90					-48 = SS Oval Handle (No Latch) & Nut
94A					-49 = Assembled Dry
94ALF-A					-50 = 2-1/4" Carbon Steel Locking Stem Extension
94MBV					-56 = Multifill Seats & Packing
NEW 94XLF					-57 = Oxygen Cleaned
95ALF					-58 = Chain Lever - Horizontal
9A					-59 = SS External Trim - 3-pc. Valves & Flange
					-60 = Grounded Ball & Stem
					-62 = Body Center Section
					-63 = NPT x Solder
					-64 = 250 SWP
					-65 = Multifill Seats & Graphite Packing
					-72 = RTFE Packing
					-83 = SS Tee Handle & Nut (77B)
					-84 = Reverse SS Tee Handle & Nut (77B)
					-85 = Short Tee Handle (77B)
					-91 = Locking SS Tee (3/4" and 1")
					-92 = Balancing Stop
					-94 = -04 & Salancing stop
					-BC = Ball Check
					-HC = Hose Thread and Cap Option
					-SV = Safety vent - 77-100/7K-100 series (Auto drain)
					-SW = Limit switch mounted
					-TH = Tested, Hydrostatic
					-TC = Tested, Hydrostatic, w/certification
					-TW = Tested, Hydrostatic, w/witness and certification

*BODY SIZE WHEN ENDS ARE MIXED.

** LEAD FREE: The wetted surfaces of this product shall contain no more than 0.25% lead by weighted average. Complies with Federal Public Law 111-380. ANSI 3rd party approved and listed.

NOTE: NOT ALL VARIATIONS AND FEATURES ARE AVAILABLE ON SAME VALVE. CONSULT CONBRACO REPRESENTATIVE.

BALL VALVES

Full-Port Bronze Ball Valves

77C-100/200 SERIES

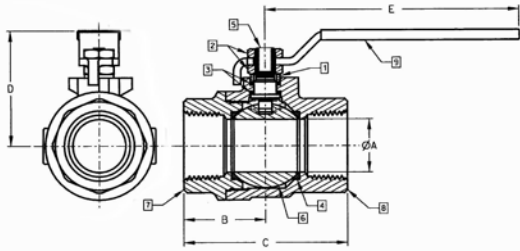

CONTRACTOR SERIES FULL PORT BRONZE BALL VALVE WITH SOLID BALL

Apollo's® solid ball design delivers true full-port performance with 100 percent American construction.

FEATURES

- ASTM grade bronze castings
- Solid brass ball, plated
- 600 psig CWP, non-shock
- 150 SWP steam rating
- Premium multi-fill MTFE seats and stem packing
- Adjustable stem packing
- Blow-out proof stem design
- Vacuum service to 29 in. Hg
- Full-port design through 2-1/2"
- Reversible handle orientation
- ANSI B16.18 solder end version available as 77C-200 Series

OPTIONS

- 2-1/4" stem extension (-04)
- CS tee handle (-07)
- Therma-Seal™ insulating tee handle (-11)
- SS Latch-lock handle (-27),
- Stem extension and balancing stop (-94)
- SS vented ball and stem (77C140 and 77C240 series)
- Other handle options available
- Also available in a Lead free version as the 77CLF Series.

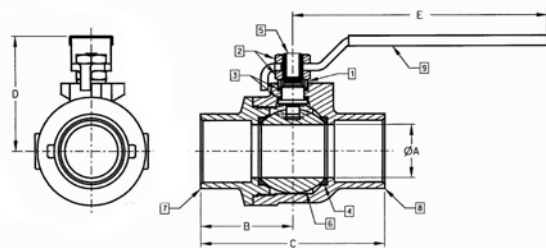

Model Number	Size (in.)	Dimensions (in.)					Cv	Wt. (lbs.)
		A	B	C	D	E		
Threaded Connection								
77C-101-01	1/4	0.37	0.95	1.97	1.76	3.74	4.5	0.6
77C-102-01	3/8	0.37	1.07	2.09	1.76	3.74	7.2	0.6
77C-103-01	1/2	0.50	1.15	2.25	1.79	3.74	15.5	0.6
77C-104-01	3/4	0.75	1.32	2.65	2.00	4.88	35.6	1.1
77C-105-01	1	1.00	1.53	3.07	2.19	4.88	68.1	1.8
77C-106-01	1-1/4	1.25	2.04	4.08	3.13	7.06	125.0	4.2
77C-107-01	1-1/2	1.50	2.21	4.43	3.29	7.06	177.0	4.6
77C-108-01	2	2.00	2.76	5.29	3.83	7.06	389.0	8.1
77C-109-01	2-1/2	2.50	3.12	6.37	4.51	8.06	503.0	16.2
Solder Connection								
77C-202-01	3/8	0.37	1.30	2.21	1.76	3.74	7.2	0.6
77C-203-01	1/2	0.50	1.41	2.58	1.79	3.74	15.5	0.6
77C-204-01	3/4	0.75	1.64	3.03	2.00	4.88	35.6	1.0
77C-205-01	1	1.00	1.92	3.61	2.19	4.88	68.1	1.6
77C-206-01	1-1/4	1.25	2.36	4.44	3.13	7.06	125.0	3.9
77C-207-01	1-1/2	1.50	2.63	4.89	3.29	7.06	177.0	5.8
77C-208-01	2	2.00	3.17	6.06	3.83	7.06	389.0	10.2
77C-209-01	2-1/2	2.50	3.77	7.14	4.51	8.06	503.0	14.8

COMMERCIAL PRODUCTS CATALOG

Full-Port Bronze Ball Valves

77CLF-100/200 SERIES

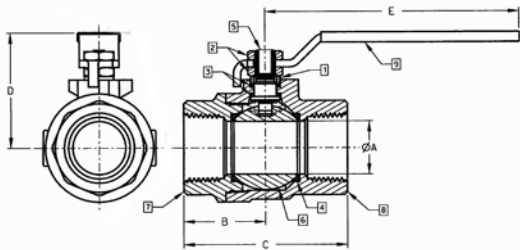

CONTRACTOR SERIES FULL PORT LEAD FREE BRONZE BALL VALVE WITH SOLID BALL
 Apollo's® solid ball design delivers true full-port performance with 100 percent American construction.

FEATURES

- ASTM grade EZ-Solder™ lead free bronze
- Solders just like standard bronze
- 600 psig CWP, non-shock
- 150 SWP steam rating
- Premium multi-fill MTFE seats and stem packing
- Adjustable stem packing
- Blow-out proof stem design
- Solid brass ball, plated
- Vacuum service to 29 in. Hg
- Full-port design through 2-1/2"
- Reversible handle orientation
- NSF/ANSI 61-G
- NSF/ANSI 372 Lead Free
- ANSI B16.18 solder end version available as 77CLF-200 Series

OPTIONS

- 2-1/4" stem extension (-04)
- CS tee handle (-07)
- Therma-Seal™ insulating tee handle (-11)
- SS Latch-lock handle (-27),
- Stem extension and balancing stop (-94)
- SS vented ball and stem (77CLF140 and 77CLF240 series)
- Other handle options available

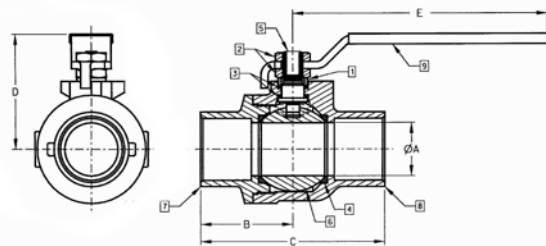

LF Model Number	Size (in.)	Dimensions (in.)					Cv	Wt. (lbs.)
		A	B	C	D	E		
Threaded Connection								
77CLF-101-01	1/4	0.37	0.95	1.97	1.76	3.74	4.5	0.6
77CLF-102-01	3/8	0.37	1.07	2.09	1.76	3.74	7.2	0.6
77CLF-103-01	1/2	0.50	1.15	2.25	1.79	3.74	15.5	0.6
77CLF-104-01	3/4	0.75	1.32	2.65	2.00	4.88	35.6	1.1
77CLF-105-01	1	1.00	1.53	3.07	2.19	4.88	68.1	1.8
77CLF-106-01	1-1/4	1.25	2.04	4.08	3.13	7.06	125.0	4.2
77CLF-107-01	1-1/2	1.50	2.21	4.43	3.29	7.06	177.0	4.6
77CLF-108-01	2	2.00	2.76	5.29	3.83	7.06	389.0	8.1
77CLF-109-01	2-1/2	2.50	3.12	6.37	4.51	8.06	503.0	16.2
Solder Connection								
77CLF-202-01	3/8	0.37	1.30	2.21	1.76	3.74	7.2	0.6
77CLF-203-01	1/2	0.50	1.41	2.58	1.79	3.74	15.5	0.6
77CLF-204-01	3/4	0.75	1.64	3.03	2.00	4.88	35.6	1.0
77CLF-205-01	1	1.00	1.92	3.61	2.19	4.88	68.1	1.6
77CLF-206-01	1-1/4	1.25	2.36	4.44	3.13	7.06	125.0	3.9
77CLF-207-01	1-1/2	1.50	2.63	4.89	3.29	7.06	177.0	5.8
77CLF-208-01	2	2.00	3.17	6.06	3.83	7.06	389.0	10.2
77CLF-209-01	2-1/2	2.50	3.77	7.14	4.51	8.06	503.0	14.8

BALL VALVES

General Purpose Ball Valves

70-100/200 SERIES



BRONZE BALL VALVE

The Apollo® 70 series is the most widely used and trusted bronze ball valve in the industry. It features blowout-proof stem, RPTFE seats and stuffing box ring and plated brass ball.

FEATURES

- Rated 600 psig CWP, non-shock
- 150 psig for saturated steam
- 100% tested
- Vacuum service to 29 in. Hg
- Adjustable packing gland
- Multiple options available (see pages 21-22)
- Lead Free option (70LF)

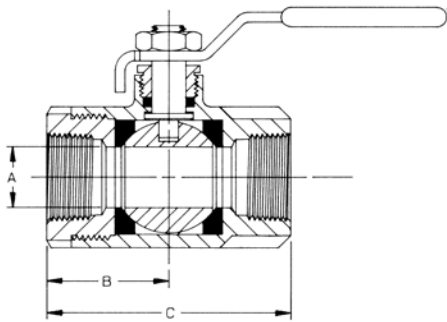

Model Number	Size (in.)	Dimensions (in.)*		
		A	B	C
NPT				
70-101-01	1/4	0.37	1.03	2.06
70-102-01	3/8	0.37	1.03	2.06
70-103-01	1/2	0.50	1.12	2.25
70-104-01	3/4	0.68	1.50	3.00
70-105-01	1	0.87	1.68	3.37
70-106-01	1-1/4	1.00	2.00	4.00
70-107-01	1-1/2	1.25	2.18	4.37
70-108-01	2	1.50	2.34	4.68
70-109-01A	2-1/2	2.00	3.12	6.25
70-100-01	3	2.50	3.37	6.75
70-10A-01	4	3.12	3.68	7.37

* Body only. Total will vary with handle and end connection options. Contact Conbraco Customer Service for additional dimensions.

NOTE: 1/4", 3/8", and 1/2" are full port.

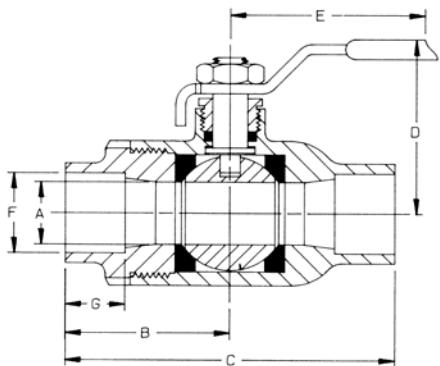

Model Number	Size (in.)	Dimensions (in.)*						
		A	B	C	D	E	F	G
Solder								
70-202-01	3/8	0.37	1.28	2.56	1.75	3.87	0.505	0.37
70-203-01	1/2	0.50	1.43	2.87	1.75	3.87	0.63	0.50
70-204-01	3/4	0.68	1.93	3.87	2.12	4.87	0.88	0.75
70-205-01	1	0.87	2.25	4.50	2.25	4.87	1.13	0.90
70-206-01	1-1/4	1.00	2.31	4.62	2.62	5.50	1.38	0.96
70-207-01	1-1/2	1.25	2.62	5.25	3.06	8.00	1.63	1.09
70-208-01	2	1.50	3.18	6.37	3.25	8.00	2.13	1.34
70-209-01A	2-1/2	2.00	3.74	7.51	3.72	8.00	2.63	1.48
70-200-01	3	2.50	4.12	8.25	4.12	8.00	3.13	1.67
70-20A-01	4	3.12	4.61	9.22	5.22	9.94	4.13	2.16

* Based on 70-200-01 – Dimensions may vary with options. Soldering temperature: 500°F or less

NOTE: 1/4", 3/8", and 1/2" are full port.

COMMERCIAL PRODUCTS CATALOG

General Purpose Ball Valves

70LF-100/200 SERIES

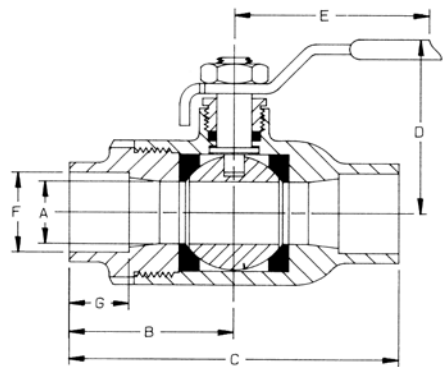
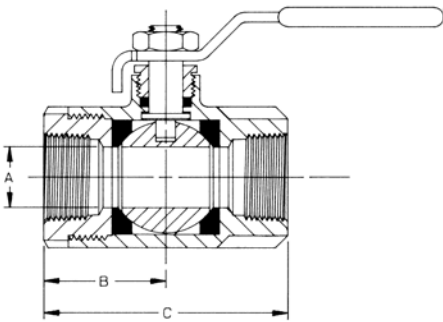

LEAD FREE BRONZE BALL VALVE

The Apollo® 70LF series is the most widely used and trusted lead free bronze ball valve in the industry. It features blowout-proof stem, RPTFE seats and stuffing box ring and plated brass ball.

FEATURES

- EZ-Solder™ Lead Free Bronze
- Solders just like standard bronze
- Rated 600 psig CWP, non-shock
- 150 psig for saturated steam
- 100% factory tested
- Vacuum service to 29 in. Hg
- NSF/ANSI 61-G
- NSF/ANSI 372 Lead Free
- Adjustable packing gland
- Multiple options available (see pages 21-22)

LF Model Number	Size (in.)	Dimensions (in.)*		
		A	B	C
NPT				
70LF-101-01	1/4	0.37	1.03	2.06
70LF-102-01	3/8	0.37	1.03	2.06
70LF-103-01	1/2	0.50	1.12	2.25
70LF-104-01	3/4	0.68	1.50	3.00
70LF-105-01	1	0.87	1.68	3.37
70LF-106-01	1-1/4	1.00	2.00	4.00
70LF-107-01	1-1/2	1.25	2.18	4.37
70LF-108-01	2	1.50	2.34	4.68
70LF-109-01A	2-1/2	2.00	3.12	6.25
70LF-100-01	3	2.50	3.37	6.75
70LF-10A-01	4	3.12	3.68	7.37

* Body only. Total will vary with handle and end connection options. Contact Conbraco Customer Service for additional dimensions.

NOTE: 1/4", 3/8", and 1/2" are full port.

LF Model Number	Size (in.)	Dimensions (in.)*						
		A	B	C	D	E	F	G
Solder								
70LF-202-01	3/8	0.37	1.28	2.56	1.75	3.87	0.505	0.37
70LF-203-01	1/2	0.50	1.43	2.87	1.75	3.87	0.63	0.50
70LF-204-01	3/4	0.68	1.93	3.87	2.12	4.87	0.88	0.75
70LF-205-01	1	0.87	2.25	4.50	2.25	4.87	1.13	0.90
70LF-206-01	1-1/4	1.00	2.31	4.62	2.62	5.50	1.38	0.96
70LF-207-01	1-1/2	1.25	2.62	5.25	3.06	8.00	1.63	1.09
70LF-208-01	2	1.50	3.18	6.37	3.25	8.00	2.13	1.34
70LF-209-01A	2-1/2	2.00	3.74	7.51	3.72	8.00	2.63	1.48
70LF-200-01	3	2.50	4.12	8.25	4.12	8.00	3.13	1.67
70LF-20A-01	4	3.12	4.61	9.22	5.22	9.94	4.13	2.16

* Based on 70-200-01 – Dimensions may vary with options. Soldering temperature: 500°F or less

NOTE: 1/4", 3/8", and 1/2" are full port.

BALL VALVES

Common Ball Valve Options

Suffix No.

-04



Apollo offers these options on the 70 Series as well as many other valve series. Note: Not all options are available on all sizes and models. Review the latest submittal sheet or contact the factory to determine availability.

STANDARD BALL VALVE WITH STEM EXTENSION

A plated steel stem extension to accommodate 2" thick pipe insulation or to relocate handle position.

-07



THREADED VALVE WITH TEE HANDLE

Plated steel tee handle is ideal when space is limited and where safety is a consideration. Handle still provides visual indication of OPEN or CLOSED position.

-08



90° REVERSED STEM

Used in applications when handle is required to be in a parallel position when closed.

-10



STAINLESS STEEL LEVER AND NUT

Additional corrosion resistance for damp or outdoor installations.

-11



THERMA-SEAL® HANDLE - **NEW** UL 2043 CLASSIFIED

The Therma-Seal thermal insulating tee-handle is designed to be use in applications where vapor barrier piping insulation is required. Manufactured from high strength glass reinforce nylon, these handles are ideally suited for the toughest commercial and industrial applications. Handles are available as a factory installed option (-11 option suffix) or as a kit for retro fits.

-16 or -58



CHAIN LEVER BALL VALVES

Reliable quarter turn operation in overhead applications. A favorite for use in industrial environments.

- Specify suffix -16 for assembly with valve in vertical position
- Specify -58 for valve in horizontal position

-17



ROUGH CHROME PLATING

Use where a clean, bright finish is required or for matching up with other chrome-plated equipment.

COMMERCIAL PRODUCTS CATALOG

Common Ball Valve Options

Apollo offers these options on the 70 Series as well as many other valve series. Note: Not all options are available on all sizes and models. Review the latest submittal sheet or contact the factory to determine availability.

Suffix No.

-27

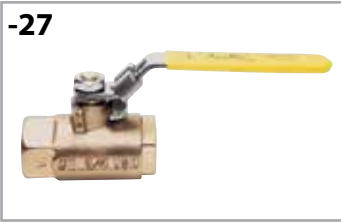

LATCH LOCK

Sliding lock mechanism secures handle in open or closed position. Valve can also be padlocked open or closed.

-30



CAM-LOCK® HANDLE

Patented Cam-Lock® handle gives valve extra protection against accidental operation. Reliable quarter-turn shut-off from a versatile, ruggedly built valve.

- RPTFE seats and stuffing box ring
- Rated 600 psig CWP, non-shock
- Available for the following Series: 70, 71, 73A, 76, 82, 83, 86, 87, 89, 9A, 92, and 96

-32 and -83



STAINLESS STEEL TEE HANDLE AND NUT

Increased corrosion resistance versus the plated steel -07 option.

- -32 for standard bronze
- -83 for 77B/77BLF and 77C/77CLF Series

-41



BALL VALVE WITH AUTOMATIC DRAIN

When this valve is closed for maintenance of pneumatic tool, downstream pressure from valve to tool is automatically drained to atmosphere to prevent accidental operation of the tool, causing possible injury.

- Conforms to certain OSHA requirements in pneumatic installations
- Easy, safe maintenance of pneumatic tools
- Cannot be used where drained media could cause damage
- Temperature range: 50°F to 200°F
- Rated 125 psig CWP, non-shock air or water
- Includes directional arrow for correct installation
- Available with latch lock option, specify -27 -41 suffix
- Available for the following Series: 70, 71, 75, and 78

-48



STAINLESS STEEL OVAL HANDLE

- Available for the following Series: 70, 71, 73A, 76, 76F, 77, 82, 83, 85, 86, 89, 9A, 92, and 96

-94



BALL VALVE WITH BALANCING STOP AND STEM EXTENSION

Ideal for HVAC systems. Stop plate and a 2-1/4" stem extension combination to accommodate insulation and handle repositioning. *Contact customer service for exact handle dimensions*

BALL VALVES

Steam Valves

70-140-64 SERIES

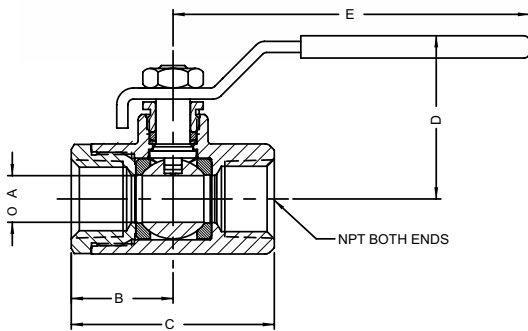

250 LB. BRONZE STEAM BALL VALVE

Designed for reliable operation on high pressure steam systems and with fluids of widely varying temperatures. Stainless steel slot vented ball and stem standard.

FEATURES

- Heavy cast bronze body
- ASTM B584 bronze body
- Slot vented stainless steel ball
- Special high-temperature MTFE seats and stem packing
- 250 SWP rating
- Red handle graphics for identification
- Made in USA

Model Number	Size (in.)	Dimensions (in.)				
		A	B	C	D	E
70-141-64	1/4	0.37	1.03	2.06	1.75	3.87
70-142-64	3/8	0.37	1.03	2.06	1.75	3.87
70-143-64	1/2	0.50	1.12	2.25	1.75	3.87
70-144-64	3/4	0.68	1.50	3.00	2.12	4.87
70-145-64	1	0.87	1.68	3.37	2.25	4.87
70-146-64	1-1/4	1.00	2.00	4.00	2.62	5.50
70-147-64	1-1/2	1.25	2.18	4.37	3.06	8.00
70-148-64	2	1.50	2.34	4.68	3.25	8.00
70-140-64	3	2.50	3.37	6.75	4.12	8.00

(Also available in 71 & 77 Series)

Bronze Ball Valves for Steam Boiler Service

70B-140 SERIES

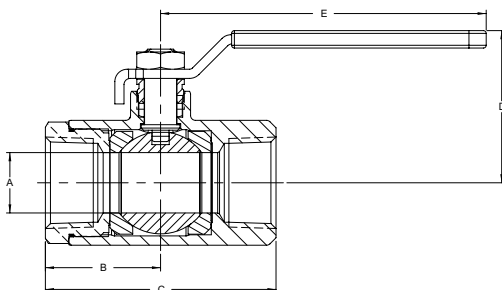
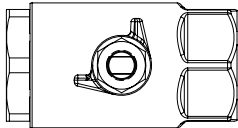

B31.1 POWER PIPING BRONZE BALL VALVE

The Apollo® 70B series offers the same rugged features as the standard 70 series valves but with materials of construction that meet the latest requirements of the ASME B31.1 Power Piping Code for steam service. This valve provides proven performance and Code compliance for B31.1 Power Piping applications.

FEATURES

- ASTM B62 Bronze body and retainer
- Stainless Steel ball & stem
- Body is marked "250 SWP" and "B62"
- Pressure balanced slot-vented ball
- Blow-out proof stem design
- Premium MPTFE seats and stem packing
- 100% factory tested
- Made in USA

Model Number	Size (in.)	Dimensions (in.)					Wt. (lb.)
		A	B	C	D	E	
70B-141-64	1/4"	0.37	1.03	2.06	1.75	3.87	0.60
70B-142-64	3/8"	0.37	1.03	2.06	1.75	3.87	0.56
70B-143-64	1/2"	0.50	1.12	2.25	1.75	3.87	0.63
70B-144-64	3/4"	0.68	1.50	3.00	2.12	4.87	1.39
70B-145-64	1"	0.87	1.68	3.37	2.25	4.87	1.72
70B-146-64	1-1/4"	1.00	2.00	4.00	2.62	5.50	3.26
70B-147-64	1-1/2"	1.25	2.18	4.37	3.06	8.00	4.61
70B-148-64	2"	1.50	2.34	4.68	3.25	8.00	6.06

COMMERCIAL PRODUCTS CATALOG

General Purpose Ball Valves

70-200-63 SERIES

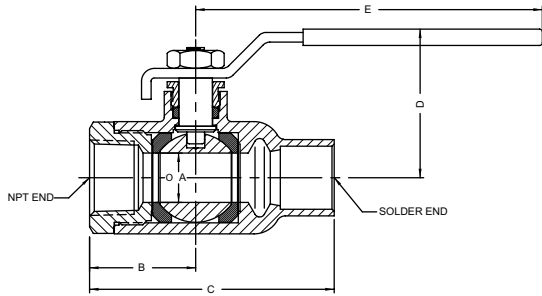

BALL VALVE WITH FNPT x SOLDER ENDS

Eliminates special pipe connector for connecting dissimilar piping such as iron and copper. Reliable shut-off and easy quarter-turn operation.

FEATURES

- Rated 600 psig CWP, non-shock
- Body is solder, retainer is threaded FNPT
- ASTM B584 Bronze
- Blowout-proof stem design
- RPTFE seats and stuffing box ring
- Vacuum service to 29 in. Hg

Model Number	Size (in.)	Dimensions (in.)				
		A	B	C	D	E
70-202-63	3/8	0.37	1.02	2.30	1.75	3.87
70-203-63	1/2	0.50	1.09	2.51	1.75	3.87
70-204-63	3/4	0.68	1.48	3.41	2.12	4.87
70-205-63	1	0.87	1.67	3.91	2.25	4.87
70-206-63	1-1/4	1.00	1.98	4.28	2.62	5.50
70-207-63	1-1/2	1.25	2.19	4.75	3.06	8.00
70-208-63	2	1.50	2.35	5.51	3.25	8.00
70-200-63	3	2.50	3.37	7.49	4.12	8.00

NOTE: 3/8" and 1/2" are full port.

70-300/400 SERIES

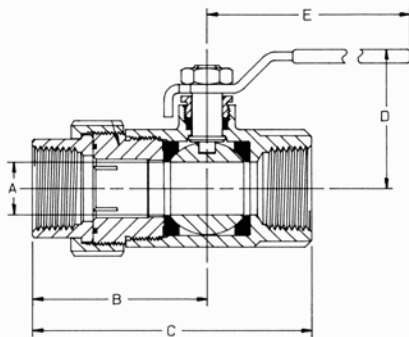

BALL VALVE WITH FNPT x UNION END

This valve combines a pipe union with ball valve shut-off; it saves time and labor by eliminating the need for extra connections. Viton O-ring sealed union requires light torque for proper seal.

FEATURES

- ASTM B584 Bronze
- Blowout-proof stem design
- Adjustable packing gland
- 600 psig CWP, non-shock
- NPT and solder union connection
- Vacuum service to 29 in. Hg
- 70LF-300/400 Series features EZ-Solder™ Lead Free Bronze

Model Number	LF Model Number	Size (in.)	Dimensions (in.)				
			A	B	C	D	E
NPT							
70-301-01	—	1/4	0.37	1.90	2.93	1.75	3.87
70-302-01	—	3/8	0.37	1.90	2.93	1.75	3.87
70-303-01	70LF-303-01	1/2	0.50	2.01	3.14	1.81	3.87
70-304-01	70LF-304-01	3/4	0.68	2.46	3.96	2.12	4.87
70-305-01	70LF-305-01	1	0.87	2.78	4.46	2.25	4.87
70-306-01	70LF-306-01	1-1/4	1.00	2.68	4.68	2.62	5.50
70-307-01	70LF-307-01	1-1/2	1.25	2.87	5.06	3.05	8.00
70-308-01	70LF-308-01	2	1.50	3.25	5.59	3.24	8.00
Solder							
70-403-01	—	1/2	0.50	2.00	3.43	1.75	3.87
70-404-01	70LF-404-01	3/4	0.68	2.62	4.56	2.06	4.78
70-405-01	70LF-405-01	1	0.87	2.81	5.06	2.25	4.78
70-406-01	70LF-406-01	1-1/4	1.00	2.87	5.18	2.62	5.50
70-407-01	70LF-407-01	1-1/2	1.25	2.92	5.53	3.10	8.00
70-408-01	70LF-408-01	2	1.50	3.50	6.75	3.24	8.00

NOTE: 1/4", 3/8", and 1/2" are full port.

BALL VALVES

Diverter Valves

70-600 SERIES

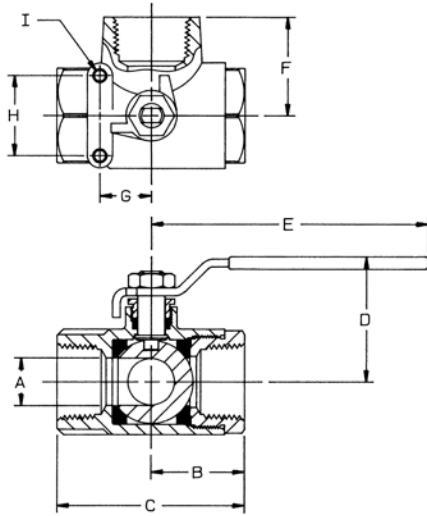

THREADED 3-WAY BALL VALVE

Ideal for applications requiring flow diversion, this valve combines the features of two valves. Its large ports make tank selection and fluid transfers quicker and easier. Easy quarter-turn operation.

FEATURES

- Simple quarter-turn operation
- ASTM B584 Bronze
- 400 psig CWP, non-shock
- Blowout-proof stem
- Adjustable stem packing
- Vacuum service to 29 in. Hg

Model Number	Size (in.)	Dimensions (in.)								
		A	B	C	D	E	F	G	H	I
70-601-01	1/4	0.37	1.12	2.32	1.80	3.88	1.18	0.875	1.37	10-24
70-602-01	3/8	0.37	1.12	2.32	1.80	3.88	1.18	0.875	1.37	10-24
70-603-01	1/2	0.50	1.09	2.25	1.75	3.87	1.18	0.87	1.37	10-24
70-604-01	3/4	0.68	1.50	3.00	2.12	4.87	1.62	0.87	1.37	10-24
70-605-01	1	0.81	1.59	3.18	2.25	4.87	1.71	0.87	1.37	10-24
70-606-01	1-1/4	1.00	1.97	3.95	2.69	5.50	2.01	0.93	1.50	1/4-20
70-607-01	1-1/2	1.25	2.21	4.40	2.87	5.50	2.38	0.94	1.50	1/4-20
70-608-01	2	1.50	2.34	4.69	3.00	5.50	2.50	0.94	1.50	1/4-20

General Purpose Ball Valves

70-800 SERIES

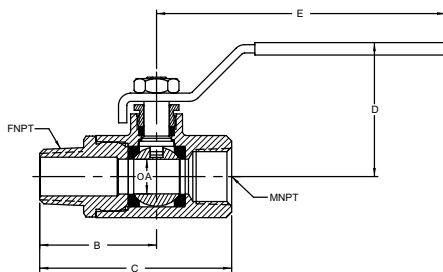

MALE X FEMALE NPT BALL VALVE

Eliminates need for extra nipple when connecting to female connection to save time and labor. Ruggedly built for lasting performance with chromium-plated ball and blowout-proof stem.

FEATURES

- 600 psig CWP, non-shock
- 150 SWP steam rating
- RPTFE seats and stuffing box ring
- Adjustable stem packing
- Vacuum service to 29" Hg.

Model Number	Size (in.)	Dimensions (in.)				
		A	B	C	D	E
70-801-01	1/4	0.37	1.40	2.43	1.75	3.87
70-802-01	3/8	0.37	1.46	2.50	1.75	3.87
70-803-01	1/2	0.50	1.68	2.81	1.81	3.87
70-804-01	3/4	0.68	2.00	3.50	2.12	4.87
70-805-01	1	0.87	2.31	4.00	2.25	4.87
70-806-01	1-1/4	1.00	2.31	4.31	2.62	5.50
70-807-01	1-1/2	1.25	3.00	5.18	3.06	8.00

NOTE: 1/4", 3/8", and 1/2" are full port.

COMMERCIAL PRODUCTS CATALOG

Diverter Valves

70-900 SERIES

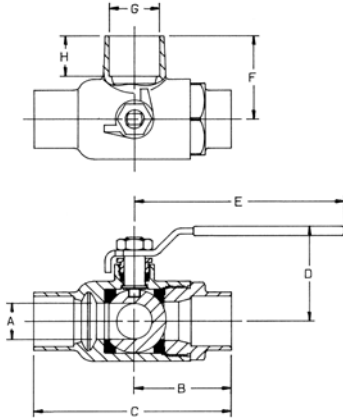

3-WAY DIVERTER VALVE WITH SOLDER ENDS

Tank selection and fluid transfers are easier because of large port diameters. The valve is 100 percent air tested under water. Designed to be soft soldered without disassembly.

FEATURES

- Simple quarter-turn operation
- ASTM B584 Bronze
- 400 psig CWP, non-shock
- Blowout-proof stem
- Adjustable packing

Model Number	Size (in.)	Dimensions (in.)							
		A	B	C	D	E	F	G	H
70-903-01	1/2	0.50	1.44	2.87	1.75	3.87	1.34	0.628	0.50
70-904-01	3/4	0.68	1.94	3.87	2.12	4.87	1.69	0.878	0.90
70-905-01	1	0.81	2.19	4.42	2.25	4.87	1.87	1.129	0.90

BALL VALVES

Specialty Valves

70-HC SERIES

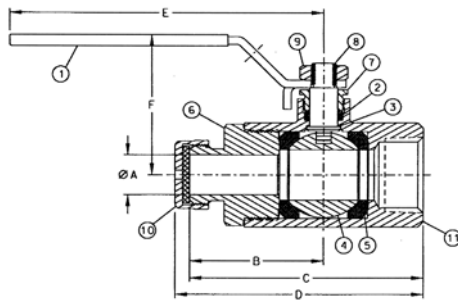
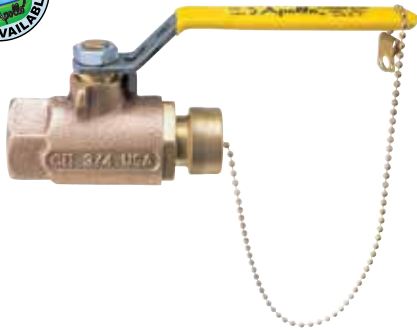

CAP & CHAIN VALVE WITH 3/4 INCH HOSE CONNECTION, HEAVY BRASS CAP AND REVERSE HANDLE

Ideally suited for HVAC systems, these valves allow direct connections to hoses. Valve features a securely attached cover (includes chain) which prevents damage to hose threads. -200 model designed for soft soldering into lines without disassembly.

FEATURES

- Reverse lever is standard for easier installation
- Stainless steel lever & nut standard
- NPT and solder connections
- EZ-Solder™ Lead Free Bronze
- ASTM B584 Bronze
- Blowout-proof stem design
- RPTFE seats and stuffing box ring
- Adjustable packing gland
- Vacuum Service to 29 in. Hg
- Maximum pressure: 600 psi CWP
- Temperature rating: 200°F
- Full pressure rated brass hose cap
- Therma-Seal® insulating lever option (-11)
- Stainless Steel ball and stem option (70-24X-HC/70LF-24X-HC)

Model Number	LF Model Number	Size (in.)	Dimensions (in.)					
			A	B	C	D	E	F
70-103-HC	70LF-103-HC	1/2 NPT x 3/4 Hose	0.50	1.68	2.81	2.97	3.87	1.75
70-104-HC	70LF-104-HC	3/4 NPT x 3/4 Hose	0.68	1.96	3.50	3.67	4.87	2.12
70-105-HC	70LF-105-HC	1 NPT x 3/4 Hose	0.87	2.24	3.92	4.16	5.28	2.43
70-203-HC	70LF-203-HC	1/2 Solder x 3/4 Hose	0.50	1.68	3.14	3.28	3.89	1.75
70-204-HC	70LF-204-HC	3/4 Solder x 3/4 Hose	0.68	1.96	3.94	4.09	4.89	2.12

Regular Port Economy Ball Valves

32-100 SERIES

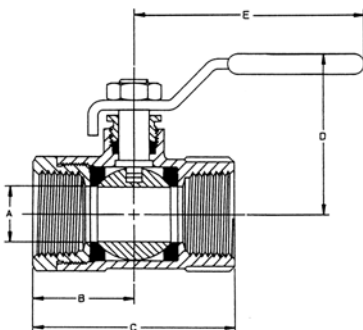

REGULAR PORT THREADED END BRONZE BALL VALVE

NPT threaded ball valve rated to 400 psig CWP, non-shock and 125 psig for saturated steam. Blowout-proof stem design with adjustable packing gland.

FEATURES

- ASTM B584 Bronze
- PTFE seats and MPTFE stuffing box ring

OPTIONS

- 2-1/4" stem extension (-04)
- Tee handle (-07)
- Round handle (-15)
- SS latch-lock lever & nut (-27)
- Balancing stop (-92)

Model Number	Size (in.)	Dimensions (in.)				
		A	B	C	D	E
32-101-01	1/4	0.37	0.80	1.60	1.65	2.87
32-102-01	3/8	0.37	0.80	1.60	1.65	2.87
32-103-01	1/2	0.40	1.00	2.00	1.68	2.87
32-104-01	3/4	0.65	1.20	2.41	1.90	3.87
32-105-01	1	0.75	1.55	3.09	2.18	4.87
32-106-01	1-1/4	1.00	1.72	3.44	2.53	5.50
32-107-01	1-1/2	1.12	1.93	3.87	2.69	5.50
32-108-01	2	1.50	2.17	4.37	2.94	5.50



For additional information, submittal sheets and manuals, visit www.apollovalves.com

Customer Service (704) 841-6000

REV. 10-9-14

COMMERCIAL PRODUCTS CATALOG

Regular Port Economy Ball Valves

32-200 SERIES

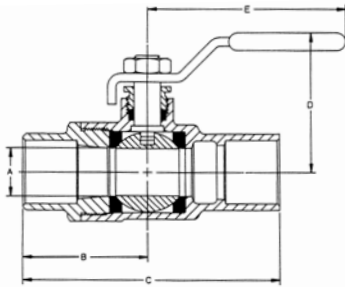

REGULAR PORT SOLDER END BRONZE BALL VALVE

Solder end ball valve with vacuum service to 29" Hg. 400 psig CWP, non-shock 125 psig for saturated steam. Blowout-proof design with adjustable packing gland.

FEATURES

- ASTM B584 Bronze
- PTFE seats and MPTFE Stuffing box ring
- Extended solder cups help protect seats from excessive heat during soldering

OPTIONS

- 2-1/4" stem extension (-04)
- Tee handle (-07)
- Round handle (-15)
- SS latch-lock lever & nut (-27)
- Balancing stop (-92)

NOTE: This valve is being discontinued. After current stock is depleted; this valve will be replaced by the 77F-200 Series.

Model Number	Size (in.)	Dimensions (in.)				
		A	B	C	D	E
32-203-01	1/2	0.40	1.29	2.65	1.68	2.87
32-204-01	3/4	0.65	1.73	3.56	1.90	3.87
32-205-01	1	0.75	2.11	4.26	2.18	4.87
32-206-01	1-1/4	1.00	2.36	4.60	2.53	5.50
32-207-01	1-1/2	1.12	2.84	5.42	2.69	5.50
32-208-01	2	1.50	3.33	6.48	2.94	5.50

Ball Valves w/Mounting Pad

71-100 SERIES

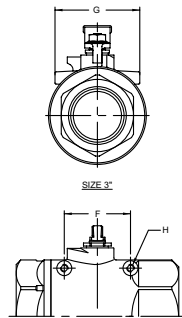
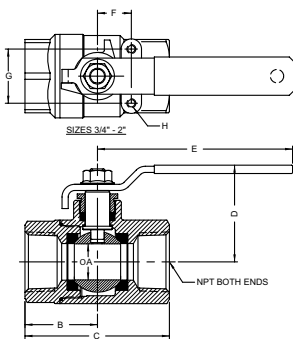
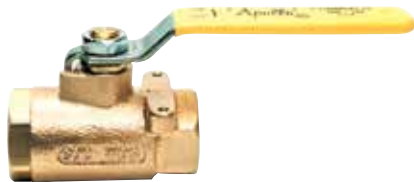

BALL VALVE WITH MOUNTING PAD

Designed to easily accommodate spring return handle, actuator or simple panel mounting. Threaded end connections with RPTFE seats and stuffing box ring.

FEATURES

- 3/4" to 3" models (See 77 Series for 1/4" - 1/2")
- 600 CWP non-shock
- Blowout-proof stem
- ASTM B584 Bronze
- Round handle option
- Adjustable packing

Model Number	Size (in.)	Dimensions (in.)							
		A	B	C	D	E	F	G	H
71-104-01	3/4	0.68	1.50	3.00	2.12	4.87	0.87	1.37	10-24 NC
71-105-01	1	0.87	1.68	3.37	2.25	4.87	0.87	1.37	10-24 NC
71-106-01	1-1/4	1.00	2.00	4.00	2.62	5.50	0.93	1.50	1/4-20 NC
71-107-01	1-1/2	1.25	2.18	4.37	2.87	8.00	0.93	1.50	1/4-20 NC
71-108-01	2	1.50	2.34	4.68	3.06	8.00	0.93	1.50	1/4-20 NC
71-100-01	3	2.50	3.37	6.75	4.12	8.00	3.37	2.75	1/4-20 NC

BALL VALVES

Shut-Off Ball Valves

71-500 SERIES

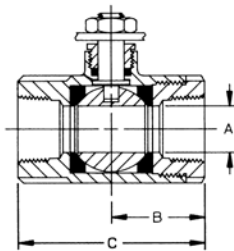
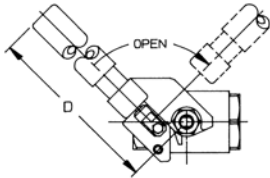

CAST BRONZE VALVE WITH SPRING RETURN HANDLE

Ideal in applications where the valve must be in OFF position at all times such as feeding fuel lines. Can be used in reverse with 90° reverse stem option. Basic configuration: spring return to CLOSED. All lever components are stainless steel.

FEATURES

- Rated 600 psig CWP, non-shock
- 150 psig for saturated steam
- Spring return to OPEN (-08)

Model Number	Size (in.)	Dimensions (in.)			
		A	B	C	D
71-501-01	1/4	0.43	1.12	2.25	7.00
71-502-01	3/8	0.50	1.12	2.25	7.00
71-503-01	1/2	0.50	1.12	2.25	7.00
71-504-01	3/4	0.68	1.50	3.00	7.00
71-505-01	1	0.87	1.68	3.37	7.00
71-506-01	1-1/4	1.00	2.00	4.00	9.00
71-507-01	1-1/2	1.25	2.18	4.37	9.00
71-508-01	2	1.50	2.34	4.68	9.00

73A-100 SERIES

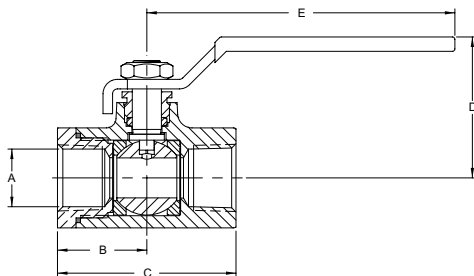
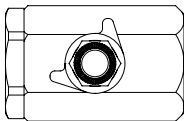

FORGED CARBON STEEL BALL VALVE

Threaded, 2 piece design, 1/4" to 1" 2000 psig CWP, 1-1/4" to 2" 1500 psig CWP Cold Non-Shock. 150 psig Saturated Steam.

FEATURES

- RPTFE seats & packing
- Forged construction
- Raised handle stops
- Blow-out-proof stem design
- Adjustable packing gland
- Zinc phosphate corrosion protection
- (-24) Fire safe to API 607 4th ed. class 600 burn
- AAR Approved #E999032
- Vacuum Service to 29 inches Hg.

Model Number	Size (in.)	Dimensions (in.)				
		A	B	C	D	E
73A-101-01A	1/4"	.37	1.02	2.30	1.72	3.85
73A-102-01A	3/8"	.37	1.08	2.37	1.72	3.85
73A-103-01A	1/2"	.50	1.18	2.31	1.78	3.85
73A-104-01A	3/4"	.68	1.57	3.07	2.07	4.75
73A-105-01A	1"	.87	1.73	3.40	2.18	4.75
73A-106-01	1-1/4"	1.00	1.98	3.97	2.72	5.50
73A-107-01	1-1/2"	1.25	2.14	4.32	3.12	7.75
73A-108-01	2"	1.50	2.73	5.44	3.27	7.75

COMMERCIAL PRODUCTS CATALOG

Stainless Steel Full Port Ball Valves

76F-100-A SERIES

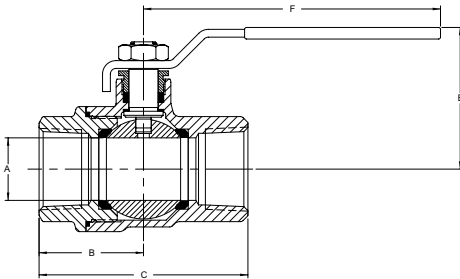
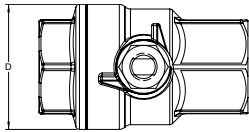

STAINLESS STEEL FULL PORT BALL VALVE

Threaded, 2 piece design, 1/2"-2" 1000 psig CWP Cold Non-Shock, 150 psig. Saturated Steam, Vacuum Service to 29 inches Hg.

FEATURES

- 316 SS Investment cast components
- RPTFE seats
- Two-piece body
- Blow-out-proof stem design
- Adjustable packing gland
- (-24) Certified to API 607, 6th Edition, Class 600 burn
- Meets NACE MR-01-75-2000
- SS lever and nut
- Available with SS latch lock lever (-27)
- Therma Seal tee handle option (-11)
- Standard valve is certified **Lead Free**
- NSF/ANSI-61-G, NSF/ANSI 372 Lead Free

Model Number	Size (in.)	Dimensions (in.)						Wt.
		A	B	C	D	E	F	
76F-103-01A	1/2"	.50	1.21	2.35	1.27	1.73	3.85	0.57
76F-104-01A	3/4"	.75	1.39	2.77	1.62	1.96	3.85	0.91
76F-105-01A	1"	1.00	1.67	3.34	2.00	2.27	4.75	1.38
76F-106-01A	1-1/4"	1.25	1.96	3.92	2.73	3.21	7.77	4.17
76F-107-01A	1-1/2"	1.50	2.05	4.10	2.92	3.31	7.77	4.69
76F-108-01A	2"	2.00	2.37	4.74	3.75	3.69	7.77	6.90

Padlocking Ball Valves

75-100-41 SERIES

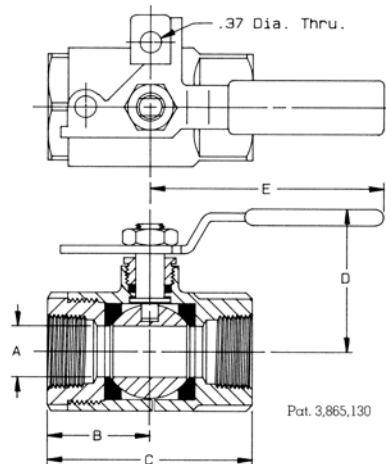

PADLOCKING BALL VALVE WITH AUTOMATIC DRAIN

Meets OSHA standards and provides for easy, safe maintenance of pneumatic tools. Valve drains downstream pressure for safety when lever is closed. Valve can be padlocked OPEN or CLOSED with same hardware.

FEATURES

- Blowout-proof stem design
- Adjustable packing gland
- ASTM B584 Bronze
- RPTFE seats and stuffing box ring
- Pad lock lever
- Rated to 125 psig - air or water
- Temperature range: 50°F to 200°F
- Valve without drain option (suffix -01)

Model Number	Size (in.)	Dimensions (in.)				
		A	B	C	D	E
75-101-41	1/4	0.43	1.12	2.25	1.81	3.00
75-102-41	3/8	0.50	1.12	2.25	1.81	3.00
75-103-41	1/2	0.50	1.12	2.25	1.81	3.00
75-104-41	3/4	0.87	1.68	3.37	2.25	3.87
75-105-41	1	0.87	1.68	3.37	2.25	3.87
75-106-41	1-1/4	1.00	2.00	4.00	2.62	5.50
75-107-41	1-1/2	1.25	2.16	4.37	2.87	5.50
75-108-41	2	1.50	2.34	4.68	3.06	5.50

BALL VALVES

Ball Valves – Full Port

77-100 SERIES

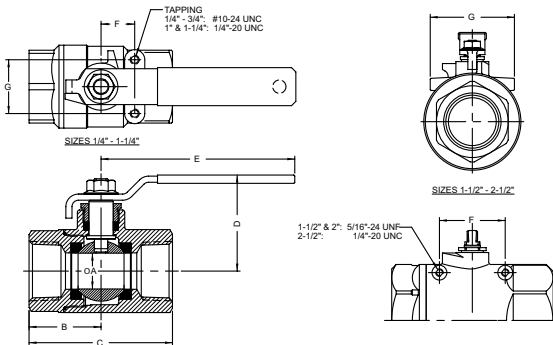

HEAVY DUTY FULL PORT NPT PANEL MOUNT BALL VALVE

Designed for easy actuator mounting or panel mounting where highest Cv values are desired. RPTFE seats and stuffing box ring. Also available with 250 lb. steam trim option.

FEATURES

- Mounting pad
- ASTM B584 Bronze
- Blowout-proof stem design
- Adjustable packing gland
- Full flow, minimum pressure drop
- 600 CWP, non-shock pressure rating
- 150 SWP steam rating
- Chain lever kits available 3/4" - 2-1/2" (-16, -58)

77 OPTIONS INCLUDE:

- 2-1/4" Stem Extension Latch Lock Lever (-27)
- Balance stop (-92)

Model Number	Size (in.)	Dimensions (in.)							Cv*
		A	B	C	D	E	F	G	
77-101-01	1/4	0.43	1.12	2.25	1.81	3.87	0.50	1.12	8.1
77-102-01	3/8	0.50	1.12	2.25	1.81	3.87	0.50	1.12	15
77-103-01	1/2	0.50	1.12	2.25	1.81	3.87	0.50	1.12	15
77-104-01	3/4	0.81	1.56	3.12	2.12	4.87	0.87	1.37	51
77-105-01	1	1.00	1.81	3.62	2.62	5.50	0.93	1.50	68
77-106-01	1-1/4	1.25	2.12	4.25	2.87	5.50	0.93	1.50	125
77-107-01	1-1/2	1.50	2.37	4.75	3.34	8.00	2.08	3.06	177
77-108-01	2	2.00	2.65	5.37	3.71	8.00	2.41	3.52	389
77-109-01	2-1/2	2.50	3.25	6.50	4.12	8.00	2.75	3.37	503

* The Cv factor is the gallons of water per minute that the valve will pass with 1 psig pressure drop.

77-200 SERIES

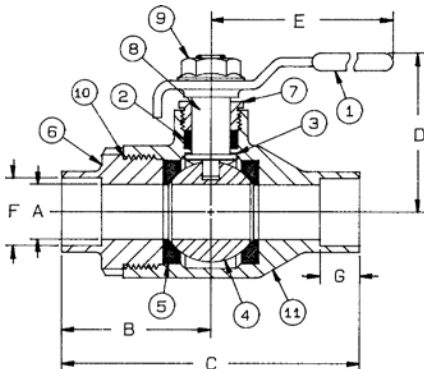

HEAVY DUTY FULL PORT SOLDER END BALL VALVE

Designed to be soldered into lines without disassembly. This allows a factory tested valve to be installed without disturbing the seats and seals. Designed for soft solder with melt points less than 500°F.

FEATURES

- Heavy duty cast bronze body
- Chromium plated ball
- Blowout-proof stem design
- Adjustable packing gland
- Full flow, minimum pressure drop
- 600 CWP, non-shock pressure rating
- 150 SWP

Model Number	Size (in.)	Dimensions (in.)						
		A	B	C	D	E	F	G
77-204-01	3/4	0.81	2.12	4.12	2.12	4.87	0.88	0.75
77-205-01	1	1.00	2.33	4.60	2.62	5.50	1.13	0.90
77-206-01	1-1/4	1.25	2.60	5.15	2.87	5.50	1.38	0.96
77-207-01	1-1/2	1.50	3.00	6.00	3.34	8.00	1.63	1.09
77-208-01	2	2.00	3.62	7.24	3.71	8.00	2.13	1.34
77-209-01	2-1/2	2.50	3.93	7.87	4.12	8.00	2.63	1.48

COMMERCIAL PRODUCTS CATALOG

"Safe" Solder/Braze Ball Valves (Two-Piece)

77-200-C8 SERIES

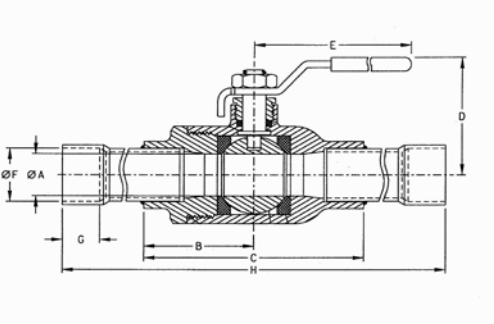

BRONZE FULL PORT BALL VALVE WITH 6" FEMALE COPPER EXTENSIONS (SOLDER CUP)

Solder end, 600 psig CWP, cold non-shock. Tube extensions allow valve to be brazed in-line without disassembly.

FEATURES

- ASTM B584 Bronze
- Adjustable packing gland
- RPTFE seats and stuffing box ring
- Blowout-proof stem design
- Full flow, minimum pressure drop

Model Number	Size (in.)	Dimensions (in.)							
		A	B	C	D	E	F	G	H
77-204-C8	3/4	0.81	2.12	4.12	2.12	4.87	0.88	0.75	16.12
77-205-C8	1	1.00	2.33	4.64	2.62	5.50	1.13	0.90	16.64
77-206-C8	1-1/4	1.25	2.60	5.15	2.87	5.50	1.38	0.96	17.15
77-207-C8	1-1/2	1.50	3.00	6.00	3.34	8.00	1.63	1.09	18.00
77-208-C8	2	2.00	3.62	7.24	3.71	8.00	2.13	1.34	19.24
77-209-C8	2-1/2	2.50	3.93	7.87	4.12	8.00	2.63	1.48	19.87

Ball Valves – Full Port – SAE Thread

77-900 SERIES

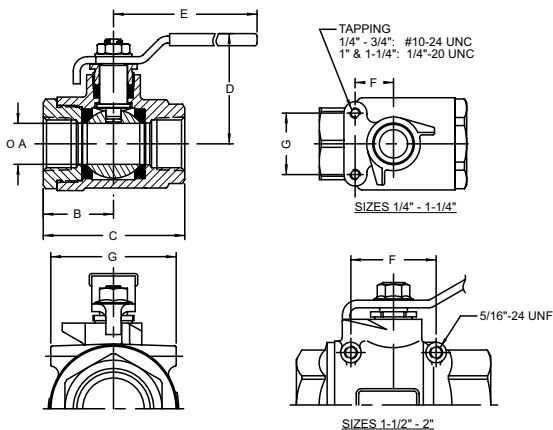

FULL PORT SAE STRAIGHT-THREAD BALL VALVES

Connections are designed for extended leak-free and energy saving performance in a broad range of applications, especially in manufacturing environments.

FEATURES

- 600 CWP non-shock
- ASTM B584 Bronze
- SAE J512/514 connections
- RPTFE seats & packing
- Blowout-proof stem and lever handle standard
- Drilled and tapped actuation pad standard

Model Number	Nom. Tube O.D. (in.)	Size (in.)	Dimensions (in.)						
			A	B	C	D	E	F	G
77-901-01	1/4	7/16-20	0.43	1.12	2.25	1.81	3.87	0.50	1.12
77-902-01	3/8	9/16-18	0.50	1.12	2.25	1.81	3.87	0.50	1.12
77-903-01	1/2	3/4-16	0.50	1.12	2.25	1.81	3.87	0.50	1.12
77-904-01	3/4	11/16-12	0.81	1.56	3.12	2.12	4.87	0.87	1.37
77-905-01	1	15/16-12	1.00	1.81	3.62	2.62	5.50	0.93	1.50
77-906-01	1-1/4	1-5/8-12	1.25	2.12	4.25	2.87	5.50	0.93	1.50
77-907-01	1-1/2	1-7/8-12	1.50	2.37	4.75	3.34	8.00	2.08	3.06
77-908-01	2	2-1/2-12	2.00	2.65	5.37	3.71	8.00	2.41	3.52

BALL VALVES

Two-Piece – Full Port Ball Valves

77B-100 SERIES



FULL PORT NPT VALVE WITH SIDE TAP

Design features lever handle and side tapping; can be used as a drain feature or with 1/8" and 1/4" test cocks, sensing lines, or pressure gauges. Offers extended service life with its ASTM B584 Bronze body, RPTFE packing and PTFE seats.

FEATURES

- Rated 400 psig CWP, non-shock
- Adjustable packing
- Blowout-proof stem design
- 125 psig SWP steam rating
- **Lead Free** option (77BLF)

OPTIONS

- All 77 levers
- SS Tee handle (-83)

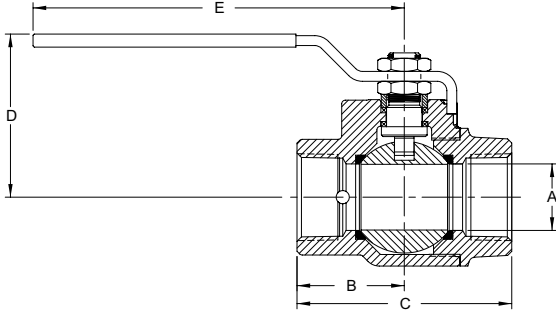
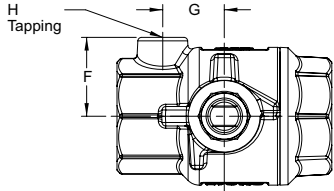

Model Number	LF Model Number	Size (in.)	Dimensions (in.)							
			A	B	C	D	E	F	G	H
77B-103-01	77BLF-103-01	1/2"	0.50	1.29	2.44	1.79	3.74	0.85	0.70	1/8 NPT
77B-104-01	77BLF-104-01	3/4"	0.75	1.48	2.81	2.00	4.75	1.00	0.80	1/8 NPT
77B-105-01	77BLF-105-01	1"	1.00	1.66	3.20	2.19	4.78	1.15	0.88	1/8 NPT
77B-106-01	77BLF-106-01	1-1/4"	1.25	2.04	4.08	3.10	7.06	1.50	1.17	1/4 NPT
77B-107-01	77BLF-107-01	1-1/2"	1.50	2.12	4.23	3.09	7.06	1.60	1.38	1/4 NPT
77B-108-01	77BLF-108-01	2"	2.00	2.42	4.85	3.45	7.08	2.00	1.56	1/4 NPT

77B-300 SERIES

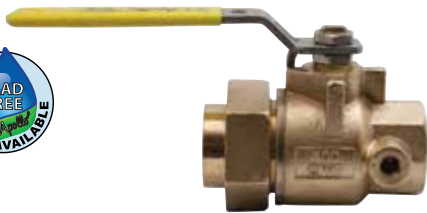

FULL PORT SINGLE UNION END VALVE WITH SIDE TAP

Valves offer union ends to make pipeline disassembly easier. Design features lever handle and side tapping; can be used as a drain feature or with 1/8" and 1/4" test cocks, sensing lines, or pressure gauges. Rated 400 psig CWP, non-shock, and is equipped with a rugged chromium-plated ball.

FEATURES

- Blowout-proof stem design
- PTFE seats
- Full flow, minimum pressure drop
- Boss not drilled and tapped option (-31)
- **Lead Free** option (77BLF)

OPTIONS

- All 77 levers
- SS Tee handle (-83)

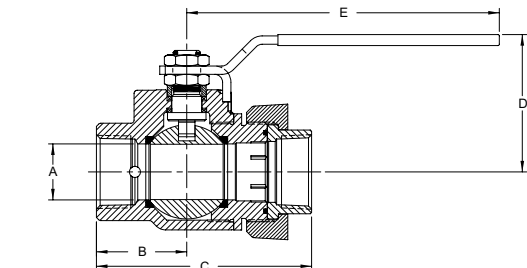
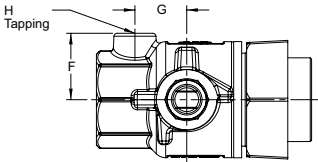

Model Number	LF Model Number	Size (in.)	Dimensions (in.)							
			A	B	C	D	E	F	G	H
77B-303-01	77BLF-303-01	1/2"	0.50	1.29	3.05	1.44	2.50*	0.85	0.70	1/8 NPT
77B-304-01	77BLF-304-01	3/4"	0.75	1.48	3.58	1.77	4.00*	1.00	0.80	1/8 NPT
77B-305-01	77BLF-305-01	1"	1.00	1.66	3.94	1.96	4.00*	1.15	0.88	1/8 NPT
77B-306-01	77BLF-306-01	1-1/4"	1.25	2.04	4.86	3.10	7.03	1.50	1.17	1/4 NPT
77B-307-01	77BLF-307-01	1-1/2"	1.50	2.12	5.35	3.09	7.09	1.60	1.38	1/4 NPT
77B-308-01	77BLF-308-01	2"	2.00	2.42	5.91	3.45	7.08	2.00	1.56	1/4 NPT

* Tee Handles



For additional information, submittal sheets and manuals, visit www.apollovalves.com

Customer Service (704) 841-6000

COMMERCIAL PRODUCTS CATALOG

Ball Valve with Direct ISO Mounting

77D SERIES



FULL PORT BRONZE BALL VALVE WITH DIRECT ISO MOUNTING PAD

Apollo's solid stainless steel ball design in a bronze valve with an integral ISO 5211 mounting pad with 100% American construction

FEATURES

- 600 CWP pressure rating
- Multi-fill seats and stem bearing
- Blowout-proof stem design
- Vacuum service to 29 in. Hg
- High cycle dual o-ring stem seal design (EPDM is standard)
- Ball is slot vented to equalize cavity and line pressure
- MSS SP-110 compliant
- Actuator ready

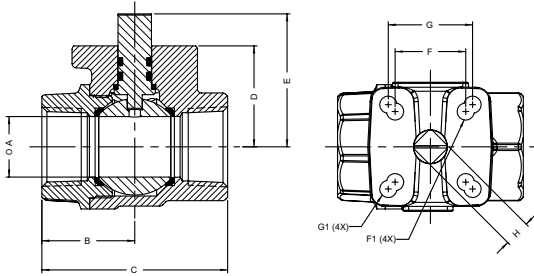

Suffix	Material	Temp Range	Steam (max)
-01E (std)	EPDM	-20 to 400°F	150 SWP @ 366°F
-01N	Nitrile	-20 to 250°F	15 SWP @ 250°F
-01V	Viton	-20 to 400°F	50 SWP @ 297°F

Model Number	Size (in.)	Dimensions (in.)									
		A	B	C	D	E	F	ØF1	G	ØG1	H
77D-143-01E	1/2	0.50	1.15	2.25	1.00	1.37	0.997	0.224	1.167	0.281	0.275
77D-144-01E	3/4	0.75	1.33	2.65	1.38	1.79	1.167	0.281	1.392	0.281	0.275
77D-145-01E	1	1.00	1.54	3.07	1.67	2.20	1.167	0.281	1.392	0.281	0.430
77D-147-01E	1-1/2	1.50	2.12	4.23	2.31	3.05	N/A	N/A	1.949	0.344	0.551
77D-148-01E	2	2.00	2.43	4.85	2.68	3.43	N/A	N/A	1.949	0.344	0.551

Gas/Fuel Shut-Off Valves

77G-UL SERIES



FULL PORT CSA & UL GAS SHUT-OFF VALVES

UL and CSA listed fuel shut off valve that features a durable bronze body, premium "multi-fill" MPTFE seats and stem packing, and a "Solid Ball" design that delivers true full port flow performance.

FEATURES

- Blowout-proof stem design
- ASTM B584 Bronze
- Maximum body pressure: 600 psig CWP
- CSA Rating: 125 psig
- CSA Rating: -20°F to 150°F
- UL Rating: 250 psig max @ 125°F
- MSS SP-110 ball valves
- CSA to ASME B16.33, 125
- CGA 3.16-M88, 125

UL LISTED

MHKZ
YSDT
YQNZ
YRBX
YRPV

UL LISTED

YRPV7
YRBX7
MHKZ7
YSDT7

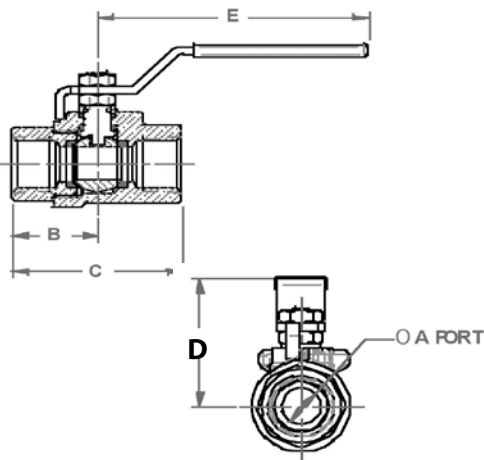

Model Number	Size (in.)	Dimensions (in.)					Wt.
		A	B	C	D	E	
77G-103-UL	1/2	0.50	1.19	2.35	1.80	3.74	0.68
77G-104-UL	3/4	0.75	1.42	2.74	1.98	4.78	1.26
77G-105-UL	1	1.00	1.64	3.18	2.18	4.78	2.08

BALL VALVES

Gas/Fuel Shut-Off Valves

80-100 SERIES

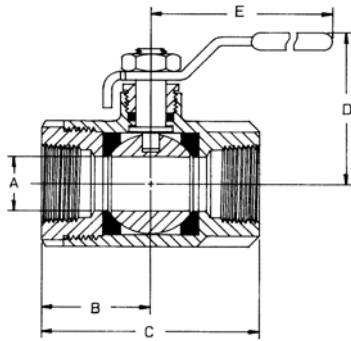
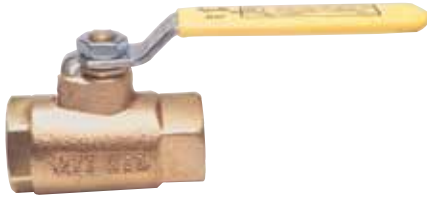

UL LISTED GAS SHUT-OFF VALVES

UL listed and designed as safe shut-off valve for LP gas, natural gas, flammable liquids and heated oil. Features easy quarter-turn ON/OFF, a large port to reduce pressure drop and NPT connections.

FEATURES

- RPTFE seats and seals
- Rated 600 psig CWP, non-shock
- 250 psig LP Gas
- Tee handle (-07)
- Latch lock handle (-27)
- Oxygen cleaned (-57)

UL LISTED

- YQNZ - UL1477
- YRBX - UL842
- YRPV - UL842
- YSDT - UL125
- MHKZ - UL842

Model Number	Size (in.)	Dimensions (in.)				
		A	B	C	D	E
80-101-01	1/4	0.37	1.03	2.06	1.75	3.87
80-102-01	3/8	0.37	1.03	2.06	1.75	3.87
80-103-01	1/2	0.50	1.12	2.25	1.81	3.87
80-104-01	3/4	0.68	1.50	3.00	2.12	4.87
80-105-01	1	0.87	1.68	3.37	2.25	4.87
80-106-01	1-1/4	1.00	2.00	4.00	2.62	5.50
80-107-01	1-1/2	1.25	2.18	4.37	2.87	5.50
80-108-01	2	1.50	2.34	4.68	3.06	5.50
80-109-01	2-1/2	2.50	3.25	6.50	4.12	8.00
80-100-01	3	2.50	3.37	6.75	4.12	8.00

Gas/Fuel Shut-Off Valves

90-100 SERIES

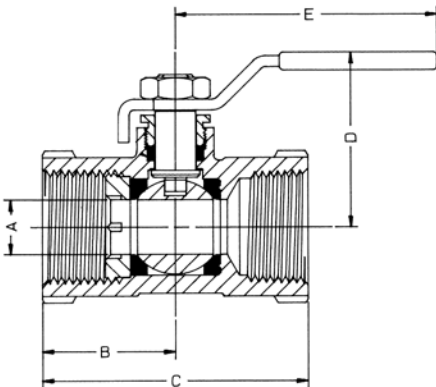

UL LISTED UNI-BODY THREADED BALL VALVE

A compact valve that's UL listed at 400 psig CWP, non-shock for fuel, inert gases and flammable liquids. Features ASTM Grade Bronze body, RPTFE seats and seals.

FEATURES

- Blowout-proof stem design
- One piece bronze body
- Optional tee handle (-07)
- Reduced port

UL LISTED

- YQNZ - UL1477
- YRBX - UL842
- YRPV - UL842

Model Number	Size (in.)	Dimensions (in.)				
		A	B	C	D	E
90-103-01A	1/2	0.37	1.14	2.15	1.68	3.87
90-104-01A	3/4	0.50	1.36	2.61	1.75	3.87
90-105-01A	1	0.62	1.50	2.90	2.00	4.87
90-106-01A	1-1/4	0.81	1.81	3.50	2.18	4.87
90-107-01A	1-1/2	1.00	2.06	3.79	2.62	5.50
90-108-01A	2	1.25	2.43	4.42	2.81	5.50

COMMERCIAL PRODUCTS CATALOG

APOLLOXPRESS® Ball Valves

77V SERIES

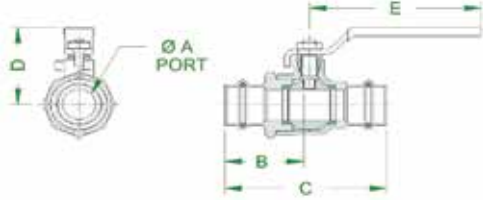

Large Diameter

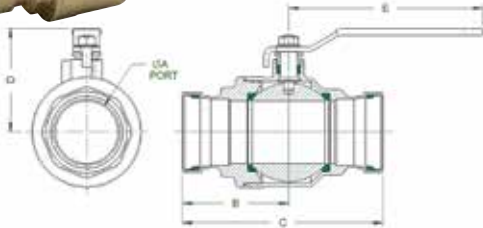

APOLLOXPRESS® PRESS END BRASS BALL VALVE

The APOLLOXPRESS® 77V Series two-piece press ball valve is ideal for installation in most HVAC systems. Features Leak Before Press® technology and 250 psig maximum working pressure. Proudly Made in the USA.

FEATURES

- 2 piece, heavy pattern forged design
- Full-Port Flow
- Max. Operating Pressure 250 psi
- Temperature Range: 0°F - 250°F
- Superior RPTFE Seats and Packing
- Adjustable Stem Packing
- Ridgid® XL Press Tool Compatible
- 2-1/2" - 4" are XLC Compatible
- Blow-Out Proof Stem
- Corrosion Resistant Materials
- Silicone Free Assembly
- 100% Factory Tested
- **Made in USA**, ARRA Compliant
- MSS SP-110 Ball Valves
- Directive 2011/65/CE (RoHS)
- Popular lever options and SS trim available

Model Number	Size (in.)	Dimensions (in.)					Wt.
		A	B	C	D	E	
77V-103-01	1/2"	0.50	1.57	2.89	1.66	2.85	0.4
77V-104-01	3/4"	0.75	1.90	3.63	1.91	3.86	0.9
77V-105-01	1"	1.00	2.20	3.88	2.11	3.86	1.2
77V-106-01	1-1/4"	1.25	2.23	4.22	2.44	4.75	2.3
77V-107-01	1-1/2"	1.50	2.84	5.45	2.91	5.42	3.4
77V-108-01	2"	2.00	3.40	6.57	3.69	7.77	6.0
77V-109-01	2-1/2"	2.50	4.26	8.04	4.13	7.77	12.0
77V-100-01	3"	3.00	5.10	9.45	5.03	9.92	19.5
77V-10A-01	4"	4.00	5.20	10.35	5.70	14.78	26.0

77VLF SERIES

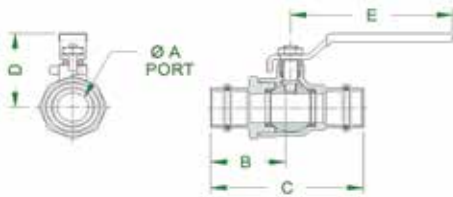

Large Diameter

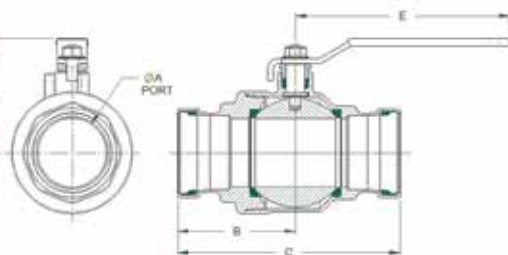

LEAD FREE APOLLOXPRESS® PRESS END BRASS BALL VALVE

The APOLLOXPRESS® 77VLF Series Lead Free two-piece press ball valve is ideal for installation in most plumbing and heating systems, including potable water. Features Leak Before Press® technology and 250 psig maximum working pressure. Proudly Made in the USA.

FEATURES

- Lead Free, ANSI 3rd Party Certified
- 2 piece, heavy pattern forged design
- Dezincification Resistant Materials
- Easily Identifiable White Handle Grip and Blue "Lead Free" Hang Tag
- Full-Port Flow
- Superior RPTFE Seats and Packing
- Adjustable Stem Packing
- Ridgid® XL Press Tool Compatible
- 2-1/2" - 4" are XLC Compatible
- Blow-Out Proof Stem
- Silicone Free Assembly
- 100% Factory Tested
- **Made in USA**, ARRA Compliant
- Maximum Operating Pressure 250 psi
- Temperature Range: 0°F - 250°F
- MSS SP-110 Ball Valves
- NSF/ANSI 61-G
- NSF/ANSI 372 Lead Free
- IAPMO IGC-157 Ball Valves
- Directive 2011/65/CE (RoHS)
- Popular lever options and SS trim available

Model Number	Size (in.)	Dimensions (in.)					Wt.
		A	B	C	D	E	
77VLF-103-01	1/2"	0.50	1.57	2.89	1.66	2.85	0.4
77VLF-104-01	3/4"	0.75	1.90	3.63	1.91	3.86	0.9
77VLF-105-01	1"	1.00	2.20	3.88	2.11	3.86	1.2
77VLF-106-01	1-1/4"	1.25	2.23	4.22	2.44	4.75	2.3
77VLF-107-01	1-1/2"	1.50	2.84	5.45	2.91	5.42	3.4
77VLF-108-01	2"	2.00	3.40	6.57	3.69	7.77	6.0
77VLF-109-01	2-1/2"	2.50	4.26	8.04	4.13	7.77	12.0
77VLF-100-01	3"	3.00	5.10	9.45	5.03	9.92	19.5
77VLF-14A-01	4"	4.00	5.20	10.35	5.70	14.78	26.0

BALL VALVES

APOLLOXPRESS® Ball Valves

77W SERIES

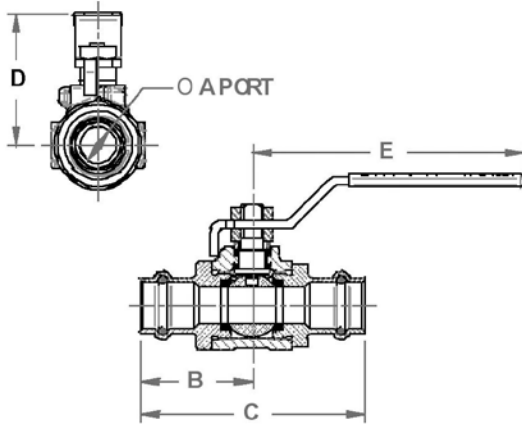

APOLLOXPRESS® BRONZE FULL PORT BALL VALVES

Apollo 77W Series APOLLOXPRESS® ball valves install in seconds, but the valve and the connection are made to last. Ideal for mechanical and heating systems. Not for use with natural gas.

FEATURES

- Full port
- Ridgid® "XL" Press Tool compatible
- Leak Before Press® technology
- 250 CWP, non-shock to 250°F max.
- MSS SP-110 ball valves
- Adjustable stem packing
- Excellent for hydronic heating (90% glycol max)
- Compatible with most 77C Series options
- Made in the USA
- **Lead Free** option (77WLF)

Model Number	Size (in.)	Dimensions (in.)					Wt.
		A	B	C	D	E	
77W-103-01	1/2	0.50	1.54	3.08	1.50	3.74	0.6
77W-104-01	3/4	0.75	1.78	3.55	2.01	4.78	1.1
77W-105-01	1	1.00	1.93	3.86	2.20	4.78	1.8
77W-106-01	1-1/4	1.25	2.44	4.87	3.13	7.04	4.3
77W-107-01	1-1/2	1.50	2.91	5.81	3.10	7.04	4.6
77W-108-01	2	2.00	3.74	7.47	3.48	7.04	8.2

77WLF SERIES

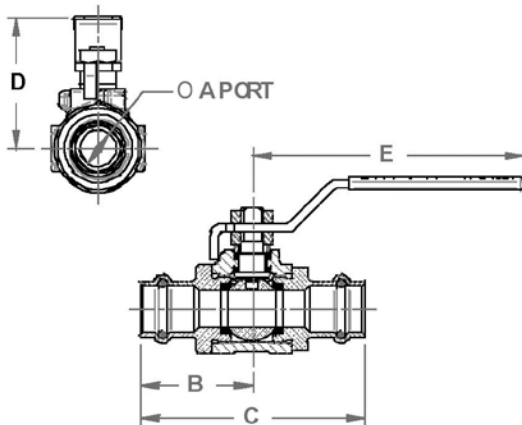

APOLLOXPRESS® LEAD FREE BRONZE FULL PORT BALL VALVES

Apollo 77WLF Series APOLLOXPRESS® ball valves install in seconds, but the valve and the connection are made to last. Ideal for most plumbing and heating systems including potable water. Not for use with natural gas.

FEATURES

- Full port
- Ridgid® "XL" Press Tool compatible
- Leak Before Press® technology
- 250 CWP, non-shock to 250°F max.
- MSS SP-110 ball valves
- NSF/ANSI 61-8 (2010) compliant
- NSF/ANSI 372 Lead Free
- Adjustable stem packing
- Excellent for hydronic heating (90% glycol max)
- Compatible with most 77C Series options
- **Made in the USA**

LF Model Number	Size (in.)	Dimensions (in.)					Wt.
		A	B	C	D	E	
77WLF-103-01	1/2	0.50	1.54	3.08	1.50	3.74	0.6
77WLF-104-01	3/4	0.75	1.78	3.55	2.01	4.78	1.1
77WLF-105-01	1	1.00	1.93	3.86	2.20	4.78	1.8
77WLF-106-01	1-1/4	1.25	2.44	4.87	3.13	7.04	4.3
77WLF-107-01	1-1/2	1.50	2.91	5.81	3.10	7.04	4.6
77WLF-108-01	2	2.00	3.74	7.47	3.48	7.04	8.2

COMMERCIAL PRODUCTS CATALOG

Forged Brass Economy Ball Valves

77F/77FLF SERIES



Large Diameter

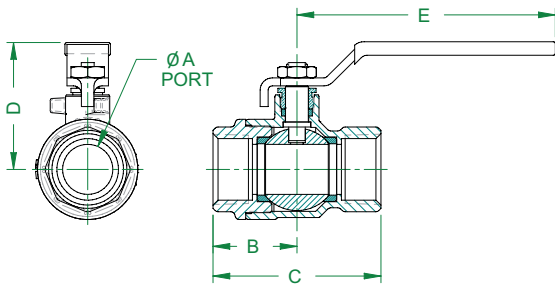

Large Diameter

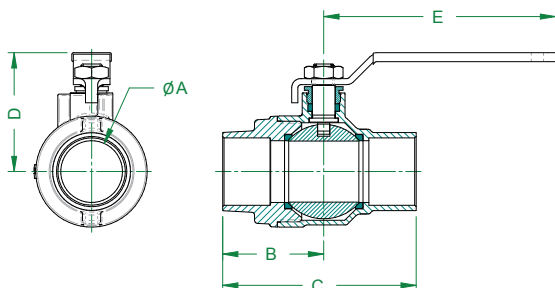

FULL PORT THREADED BRASS BALL VALVES

The Apollo 77F Series is a full port forged brass ball valve suitable for a wide range of plumbing and heating applications. These NPT threaded or solder, 2-piece valves combine reliable operation with maximum economy. Valves include most pertinent agency approvals. Proudly Made in the USA.

FEATURES

- Heavy Pattern Forged Design
- Full-Port Flow
- Superior RPTFE Seats and Packing
- Adjustable Stem Packing
- Blow-Out Proof Stem
- Corrosion Resistant Materials
- 100% Factory Tested
- Silicone Free Assembly
- **Made in USA**, ARRA Compliant
- Rating: 600 CWP (1/4" - 2")
- Rating: 400 CWP (2-1/2" - 4")
- Steam Rating: 150 psi SWP
- Vacuum Service to 29 in. Hg

77FLF FEATURES

- Easily Identifiable White Handle Grip and Blue "Lead Free" Hang Tag
- Lead Free Dezincification Resistant Brass
- NSF/ANSI 61-G
- NSF/ASNI 372 Lead Free
- Rating: 600 CWP (1/4" - 2")
- Rating: 400 CWP (2-1/2" - 4")
- Steam Rating: 150 psi SWP
- Vacuum Service to 29 in. Hg

Model Number	LF Model Number	Size (in.)	Dimensions (in.)					Wt.
			A	B	C	D	E	
NPT								
77F-101-01	77FLF-101-01	1/4"	0.38	0.81	1.62	1.61	2.85	0.3
77F-102-01	77FLF-102-01	3/8"	0.38	0.85	1.70	1.61	2.85	0.3
77F-103-01	77FLF-103-01	1/2"	0.50	1.14	2.25	1.66	2.85	0.5
77F-104-01	77FLF-104-01	3/4"	0.75	1.26	2.51	1.91	3.86	0.8
77F-105-01	77FLF-105-01	1"	1.00	1.60	3.20	2.11	3.86	1.3
77F-106-01	77FLF-106-01	1-1/4"	1.25	1.73	3.46	2.44	4.75	2.1
77F-107-01	77FLF-107-01	1-1/2"	1.50	2.00	4.00	2.91	5.42	3.2
77F-108-01	77FLF-108-01	2"	2.00	2.37	4.47	3.69	7.77	5.6
77F-109-01	77FLF-109-01	2-1/2"	2.50	2.99	5.98	4.14	7.77	12.8
77F-100-01	77FLF-100-01	3"	3.00	3.52	7.05	5.03	9.92	19.7
77F-10A-01	77FLF-14A-01	4"	4.00	3.83	7.65	5.70	14.78	25.5

Model Number	LF Model Number	Size (in.)	Dimensions (in.)					Wt.
			A	B	C	D	E	
Solder								
77F-203-01	77FLF-203-01	1/2"	0.50	1.37	2.37	1.66	2.85	0.4
77F-204-01	77FLF-204-01	3/4"	0.75	1.72	3.13	1.91	3.86	0.9
77F-205-01	77FLF-205-01	1"	1.00	2.01	3.73	2.11	3.86	1.3
77F-206-01	77FLF-206-01	1-1/4"	1.25	2.07	3.97	2.44	4.75	2.0
77F-207-01	77FLF-207-01	1-1/2"	1.50	2.42	4.69	2.91	5.42	3.3
77F-208-01	77FLF-208-01	2"	2.00	2.91	5.82	3.69	7.77	5.6
77F-209-01	77FLF-209-01	2-1/2"	2.50	3.68	7.05	4.14	7.77	11.6
77F-200-01	77FLF-200-01	3"	3.00	4.26	8.15	5.03	9.92	19.3
77F-20A-01	77FLF-24A-01	4"	4.00	4.82	9.57	5.70	14.78	25.6

APPROVALS

- MSS-SP-110
- IAPMO IGC-157 Ball Valves
- CGA 3.16 (125 PSI)
- CGA CR91-002 (5 PSI)
- ANSI Z21.15/CSA 9.1 (1/2 PSI)
- ASME B16.44 (5 PSI)
- ASME B16.33 (125 PSI) (1/2" - 2")



- FM 1140 (1/4" - 2")
- UL Guides: YSDT, MHKZ, YQNZ, YRBX & YRPV
- UL Guide VQGU (1/4" - 2")



BALL VALVES

APOLLOXPRESS® Ball Valves

77W-HC SERIES

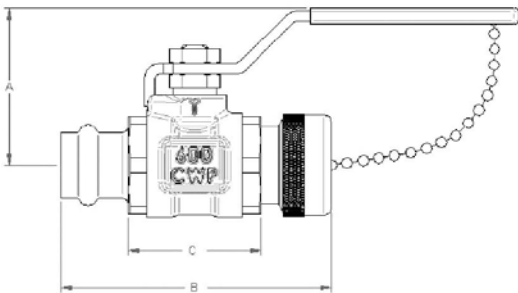

APOLLOXPRESS® x HOSE CAP & CHAIN BALL VALVE

Designed for direct mechanical connection to ASTM B88-Type K,L, and M copper tubing in the hard drawn condition for sizes 1/2"-3/4". Valves feature a 3/4" hose thread connection with heavy brass cap to protect the threads and is full pressure rated. Not for use with natural gas.

FEATURES

- Full port
- Ridgid® "XL" Press Tool compatible
- Leak Before Press® technology
- MSS SP-110 ball valves
- NSF/ANSI 61-G compliant (77WLF-HC)
- 77WLF supplied with Easily Identifiable White Handle Grip and Blue "Lead Free" Hang Tag
- Adjustable stem packing
- 250 CWP, non-shock to 250°F max.
- Excellent for hydronic heating (90% glycol max)
- Compatible with most 77C Series options
- **Made in the USA**
- Heavy brass dust cover is full pressure rated

Model Number	LF Model Number	Size (in.)	Dimensions (in.)			Wt. (lbs.)
			A	B	C	
77W-103-HC	77WLF-103-HC	1/2	1.80	3.12	1.54	0.61
77W-104-HC	77WLF-104-HC	3/4	2.01	3.45	1.72	1.09

Surface Mount Shut-Off Valves

78-256 SERIES

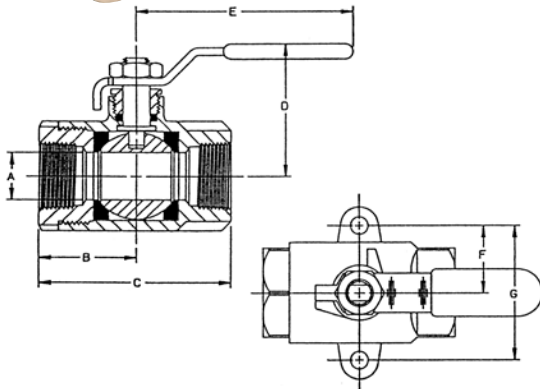
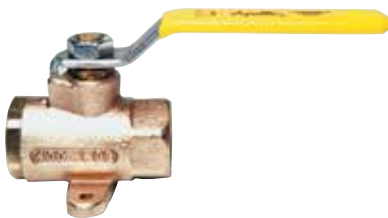

MULTI PURPOSE SHUT-OFF VALVE WITH MOUNTING EARS

Excellent for use with liquid fuels and often specified as a fuel tank shut-off valve in marine applications. All wetted parts are brass or cast bronze. Mounting ears for easy, positive installation.

FEATURES

- 400 psig CWP, non-shock
- Tested to 100 psig air under water
- Optional tee handle
- NPT threaded, both ends
- RPTFE seats and seals

Model Number	Size (in.)	Dimensions (in.)						
		A	B	C	D	E	F	G
78-248-01	1/4	0.43	1.12	2.25	1.78	3.87	0.93	1.87
78-250-01	3/8	0.43	1.12	2.25	1.78	3.87	0.93	1.87
78-256-01	1/2	0.50	1.12	2.25	1.78	3.87	0.93	1.87
78-438-01	3/4	0.68	1.50	3.00	2.12	4.87	1.06	2.12

COMMERCIAL PRODUCTS CATALOG

Instrumentation Valves

78-260/290 SERIES



78-290: Bronze

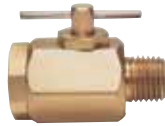

78-260: Bronze

Brass Valves

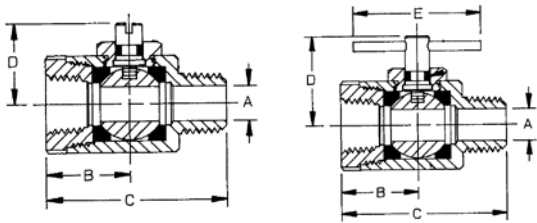

Bronze Valves

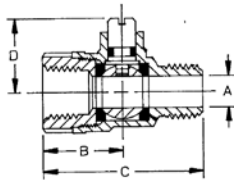

BRASS AND BRONZE INSTRUMENTATION BALL VALVES

Male x Female threaded. 400 psig CWP, non-shock. Air and liquid service.

FEATURES

- Micro-finish ball
- Blowout-proof stem design
- PTFE seats
- Nitrile stem seal
- Plated steel tee handle
- Compact design
- Optional mixed end fittings available

BRASS INSTRUMENTATION BALL VALVE - TEE HANDLE

Model Number	Size (in.)	Dimensions (in.)					Cv*	Wt.
		A	B	C	D	E		
78-260-05	1/8M x 1/8F	0.21	0.37	1.43	0.87	1.25	4.00	0.20
78-261-05	1/4M x 1/4F	0.31	0.43	1.43	0.87	1.25	5.50	0.19

BRASS INSTRUMENTATION BALL VALVE - SCREW SLOT

Model Number	Size (in.)	Dimensions (in.)					Cv*	Wt.
		A	B	C	D	E		
78-262-05	1/8M X 1/8F	0.21	0.37	1.43	0.75	N/A	4.00	0.20
78-263-05	1/4M X 1/4F	0.31	0.43	1.43	0.75	N/A	5.50	0.19

BRONZE INSTRUMENTATION BALL VALVE (INTERNATIONAL) - SCREW SLOT

Model Number	Size (in.)	Dimensions (in.)					Cv*	Wt.
		A	B	C	D	E		
78-290-01	1/8M x 1/4F	0.21	0.80	1.60	0.72	N/A	4.00	0.19
78-291-01	1/4M x 1/4F	0.31	0.80	1.60	0.72	N/A	5.50	0.19
78-292-01	1/8 x 1/4 SAE	0.21	0.80	1.60	0.72	N/A	4.00	0.19
78-293-01	1/4 x 1/4 SAE	0.31	0.80	1.60	0.72	N/A	5.50	0.19

* The Cv factor is the gallons of water per minute that the valve will pass with a 1 psig pressure drop.

Specialty Valves

78-274-01 SERIES

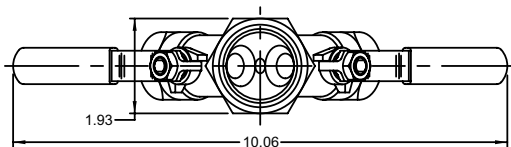

DUAL WYE AUTO DRAIN BALL VALVE

Dual action modular valve, ideal for compressor applications where safety exhaust may be needed for two air lines at once.

FEATURES

- 1-1/4" FNPT Inlet x (2) 3/4" FNPT outlets
- 600 CWP
- ASTM B584 Bronze

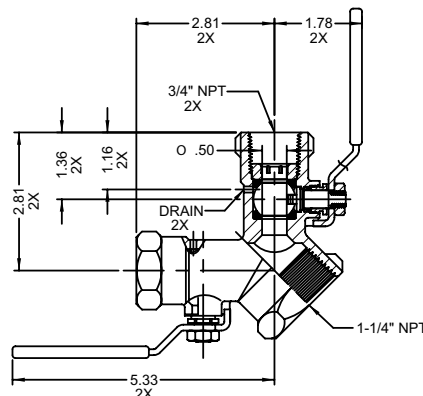

BALL VALVES

Irrigation Valves

78-130 SERIES

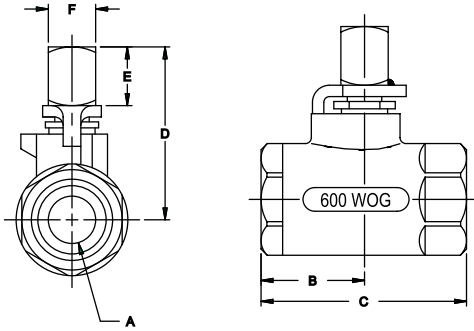

FEMALE END VALVE FOR UNDERGROUND SERVICE

Ideal for underground or below grade applications. This series (3/8"-2" FNPT) features a square head nut welded to the stem to allow operations with a ground key from standard grade.

Model Number	Size (in.)	Dimensions (in.)					
		A	B	C	D	E	F
78-132-01	3/8	0.37	1.03	2.06	1.75	0.62	0.50
78-133-01	1/2	0.50	1.09	2.18	1.83	0.62	0.50
78-134-01	3/4	0.68	1.50	3.00	2.12	0.62	0.62
78-135-01	1	0.87	1.68	3.37	2.25	0.62	0.62
78-136-01	1 1/4	1.00	2.00	4.00	2.88	0.75	0.75
78-137-01	1 1/2	1.25	2.18	4.38	3.06	0.75	0.75
78-138-01	2	1.50	2.34	4.68	3.25	0.75	0.75

78-114-01 SERIES



SAE MALE THREAD VALVE FOR UNDERGROUND SERVICE

Features the same square head nut as the 78-130 Series but with an optional SAE male thread on one end. Apollo valves can be manufactured with a variety of end connections.

FEATURES

- 1-1/16 SAE male o-ring x 3/4 FNPT

78-620 SERIES



BRONZE NPT IRRIGATION VALVE WITH AUTO-DRAIN

Ideal for underground use or where drained media will not cause damage. Heavy pattern design features ASTM B584 Bronze body.

FEATURES

- Auto-drain feature (when valve is in closed position) is standard
- Adjustable packing gland
- RPTFE seats and seals
- Stainless steel cover
- 200 psig water, CWP, non-shock
- Temperature range +50°F to 200°F

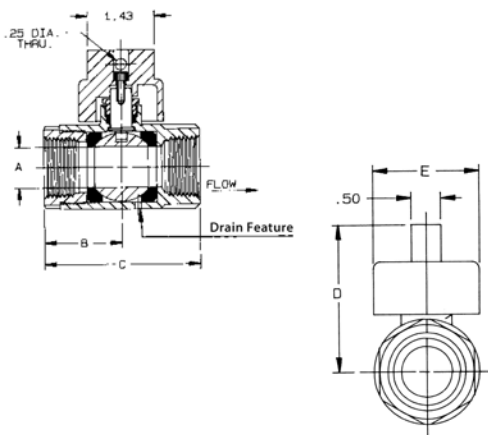

Model Number	Size (in.)	Dimensions (in.)				
		A	B	C	D	E
78-621-01	3/4	0.68	1.47	2.96	2.40	1.81
78-622-01	1	0.87	1.66	3.34	2.53	1.81
78-623-01	1-1/4	1.00	1.98	3.97	3.00	2.50
78-624-01	1-1/2	1.25	2.12	4.28	3.18	2.50
78-625-01	2	1.50	2.35	4.67	3.37	2.50

COMMERCIAL PRODUCTS CATALOG

Purge & Drain Valves

78-660 & 962 SERIES

BRONZE BALL VALVE WITH CENTER DRAIN

Center tap drain allows for winterization or purge and drain function. Features bronze body with built-in mounting pad for panel mounting or actuation. Ideal for hydronic heating and marine applications.

FEATURES

- 1/8" NPT side tap and plug
- RPTFE seats and stuffing box ring
- Stainless steel lever and nut
- Blowout-proof stem
- 600 psig CWP, non-shock
- Adjustable packing
- Drainable ball cavity to prevent freezing

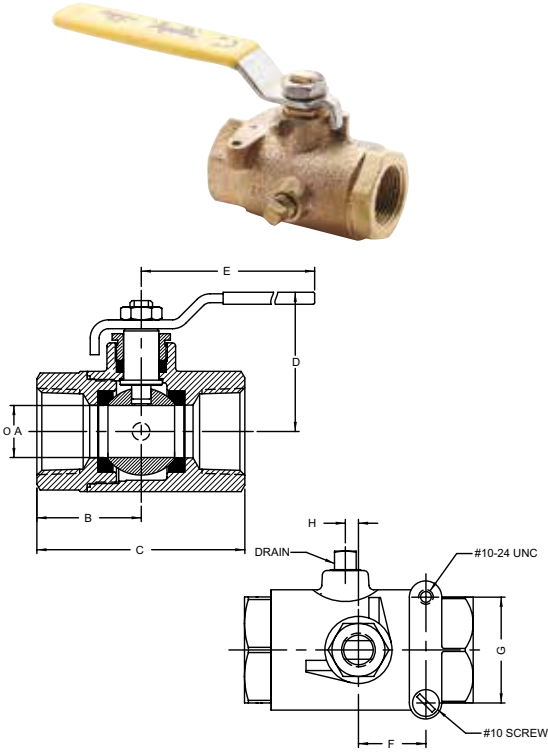

Model Number	Size (in.)	Dimensions (in.)							
		A	B	C	D	E	F	G	H
78-664-01	3/4	0.68	1.50	3.00	2.12	4.87	0.87	1.37	0.17
78-665-01	1	0.87	1.68	3.37	2.25	4.87	0.87	1.37	0.21
78-666-01	1-1/4	1.00	2.00	4.00	2.62	5.50	0.93	1.50	0.28
78-667-01	1-1/2	1.25	2.18	4.37	3.05	8.00	0.93	1.50	0.40
78-962-01	2	1.50	2.34	4.68	3.24	8.00	0.93	1.50	0.45

"Safe" Solder Valves (Two-Piece)

79-700 SERIES

UL-LISTED REFRIGERANT BALL VALVE ASSEMBLY

Complete hermetically welded assembly includes copper extensions and forged brass refrigerant ball valve with capped, triple-sealed stem to minimize leaks.

FEATURES

- Chrome plated ball
- RPTFE seats and seals
- Full port through 2-5/8"
- Bi-directional flow design
- Sizes from 3/8" to 3-1/8" O.D. tube
- All sizes UL listed - SFJQ
- Rated 500 psig CWP, non-shock
- For use with refrigerant Group 2 fluids

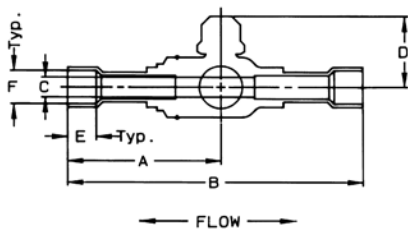

Model Number	Size (in.)	Dimensions (in.)							Cv*
		A	B	C	D	E	F		
79-701-01	3/8	3.38	6.45	0.45	1.56	0.38	0.38	8.5	
79-702-01	1/2	3.38	6.45	0.45	1.56	0.38	0.50	8.5	
79-703-01	5/8	3.56	6.82	0.50	1.56	0.50	0.62	9.8	
79-704-01	7/8	3.91	7.53	0.68	1.79	0.75	0.87	32.0	
79-705-01	1-1/8	4.39	8.51	0.87	1.98	0.90	1.12	44.0	
79-706-01	1-3/8	4.42	8.94	1.25	2.62	0.96	1.38	66.0	
79-707-01	1-5/8	4.55	9.19	1.25	2.62	1.09	1.62	148.0	
79-708-01	2-1/8	5.16	10.31	1.50	2.93	1.34	2.12	218.0	
79-709-01	2-5/8	6.50	13.00	2.50	3.90	1.48	2.62	440.0	
79-600-01	3-1/8	7.00	14.00	2.50	3.90	1.67	3.12	390.0	

* The Cv factor is the gallons of water per minute that the valve will pass with 1 psig pressure drop.

BALL VALVES

Air Exhaust Valves

7K-100 SERIES

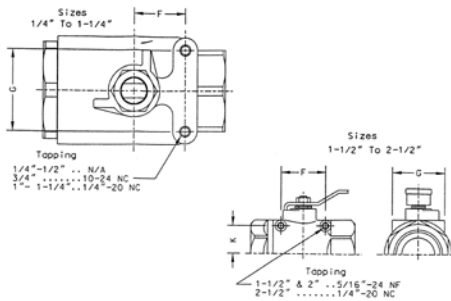
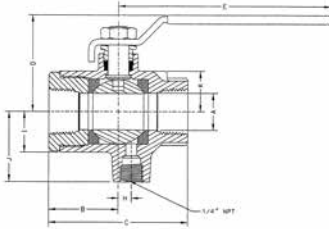

Notes: This View NOT TO SCALE

FULL PORT SAFETY EXHAUST VALVE WITH 1/4" NPT TAP FOR DRAIN

For use on pneumatic equipment. Furnished with a 1/4" NPT tapped drain to accommodate a muffler or to pipe the exhausted air to a safe location.

FEATURES

- Safely vents compressed air (or other non-hazardous gases) from piping downstream of the closed valve
- Sizes 1/4" - 2-1/2"
- FNPT threads
- Rated 125 psig-air or water, CWP, non-shock
- Temperature range: +50°F - +200°F
- Optional stainless steel latch lock handle that locks in closed position only, specify suffix (-46)

Model Number	Size (in.)	Dimensions (in.)										
		A	B	C	D	E	F	G	H	I	J	K
7K-101-01	1/4	0.37	1.03	2.06	1.75	3.87	N/A	N/A	0.09	0.53	1.18	N/A
7K-102-01	3/8	0.37	1.03	2.06	1.75	3.87	N/A	N/A	0.09	0.53	1.18	N/A
7K-103-01	1/2	0.50	1.10	2.19	1.75	3.87	N/A	N/A	0.12	0.59	1.25	N/A
7K-104-01	3/4	0.81	1.56	3.12	2.12	4.78	0.87	1.37	0.29	0.90	1.56	0.90
7K-105-01	1	1.00	1.80	3.61	2.62	5.50	0.93	1.50	0.31	1.12	1.78	1.12
7K-106-01	1-1/4	1.25	2.12	4.25	2.87	5.50	0.93	1.50	0.37	1.37	2.03	1.37
7K-107-01	1-1/2	1.50	2.37	4.74	3.30	7.78	2.08	3.06	0.50	1.56	2.21	1.28
7K-108-01	2	2.00	2.70	5.38	3.71	7.78	2.41	3.52	0.62	2.03	2.68	1.56
7K-109-01	2-1/2	2.50	3.25	6.50	4.05	7.78	2.75	3.37	1.09	2.34	3.00	2.00

Also available in 70 & 77 Series as -41 option (without tapped drain)

Air Exhaust Valves

7K-SV SERIES



(7K-SV Series Shown)

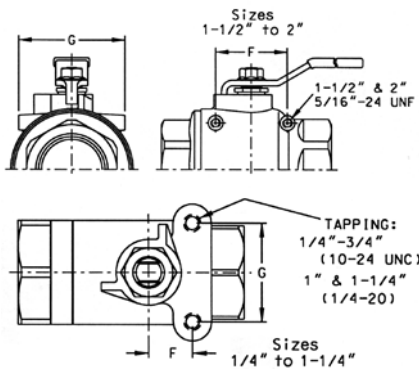

SECURE-VENT FEATURE (-SV)

Available on the Apollo 77 and 7K full port bronze ball valves. Safely vents compressed air (or other non-hazardous gases) from piping downstream of the closed valve.

FEATURES

- Reliable shut-off and venting
- Pressure rating: 200 psig CWP, non-shock
- Temp. range: -20°F to 200°F
- Economical "no leakage" operation
- Belleville spring live-loaded active upstream seating
- Available with a full complement of handles

Model Number	Size (in.)	Dimensions (in.)						
		A	B	C	D	E	F	G
7K-101-SV	1/4	0.43	1.43	2.52	1.76	3.88	0.50	1.12
7K-102-SV	3/8	0.50	1.60	2.69	1.76	3.88	0.50	1.12
7K-103-SV	1/2	0.50	1.50	2.59	1.76	3.88	0.50	1.12
7K-104-SV	3/4	0.81	1.82	3.37	2.16	5.43	0.87	1.37
7K-105-SV	1	1.00	2.05	3.86	2.69	5.43	0.93	1.50
7K-106-SV	1 1/4	1.25	2.37	4.50	2.91	5.43	0.93	1.50
7K-107-SV	1 1/2	1.50	2.37	7.78	3.31	7.78	2.08	3.06
7K-108-SV	2	2.00	3.00	5.69	3.73	7.78	2.40	3.52

COMMERCIAL PRODUCTS CATALOG

Three-Piece Full Port Valves

82-100 SERIES

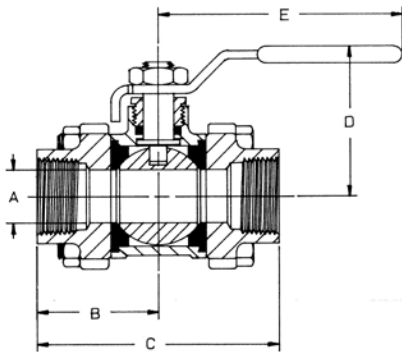
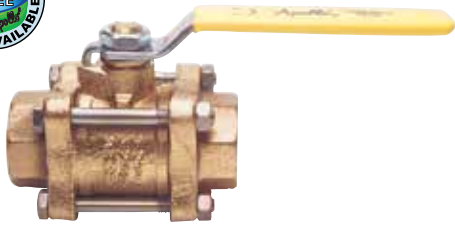

FULL PORT BRONZE NPT THREE-PIECE VALVE

This inline-repairable threaded ball valve offers RPTFE seats and seals and a 600 CWP, non-shock rating.

FEATURES

- ASTM B584 Bronze body and ends
- SAE Grade 8 body bolts
- Adjustable packing nut
- Full port flow
- 600 CWP, 150 SWP
- Numerous options available
- 82-14X with SS ball and stem option
- **Lead Free** option (82LF)
 - NSF/ANSI 61-G and NSF/ANSI 372 Lead Free
 - Easily Identifiable White Handle Grip and Blue "Lead Free" Hang Tag

Model Number	LF Model Number	Size (in.)	Dimensions (in.)				
			A	B	C	D	E
82-101-01	82LF-101-01	1/4	0.43	1.28	2.56	1.81	3.87
82-102-01	82LF-102-01	3/8	0.50	1.28	2.56	1.81	3.87
82-103-01	82LF-103-01	1/2	0.62	1.40	2.81	1.93	4.87
82-104-01	82LF-104-01	3/4	0.81	1.71	3.43	2.18	4.87
82-105-01	82LF-105-01	1	1.00	1.93	3.87	2.62	5.50
82-106-01	82LF-106-01	1-1/4	1.25	2.37	4.75	2.87	5.50
82-107-01	82LF-107-01	1-1/2	1.50	2.62	5.25	3.37	8.00
82-108-01	82LF-108-01	2	2.00	3.01	6.03	3.68	8.00
82-109-01	82LF-109-01	2-1/2	2.50	3.62	7.25	5.14	9.75
82A-140-01	-	3	3.00	4.18	8.37	8.10	19.13
82A-14A-01	-	4	4.00	5.43	10.86	8.88	19.13

82-200 SERIES

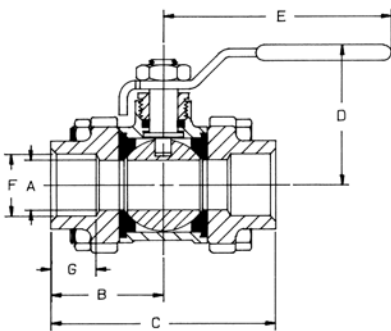
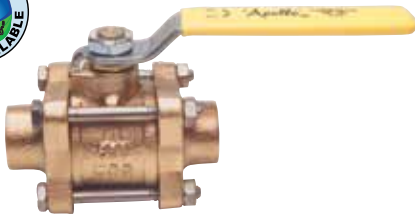

FULL PORT BRONZE THREE-PIECE SOLDER/BRAZED END VALVE

Valve features full port and is easily repaired inline. Designed for soft soldering or brazed* installation. Includes RPTFE seats and seals.

FEATURES

- ASTM B584 Bronze
- SAE Grade 8 body bolts
- 600 CWP, non-shock
- 150 SWP steam rating
- 82-24X with SS ball and stem option
- **Lead Free** option (82LF) featuring EZ-Solder™ Lead Free Bronze
 - NSF/ANSI 61-G and NSF/ANSI 372 Lead Free
 - Easily Identifiable White Handle Grip and Blue "Lead Free" Hang Tag

Model Number	LF Model Number	Size (in.)	Dimensions (in.)						
			A	B	C	D	E	F	G
82-202-01	82LF-202-01	3/8	0.50	1.28	2.56	1.81	3.87	0.50	0.37
82-203-01	82LF-203-01	1/2	0.62	1.40	2.81	1.93	4.87	0.63	0.50
82-204-01	82LF-204-01	3/4	0.81	1.71	3.43	2.18	4.87	0.88	0.75
82-205-01	82LF-205-01	1	1.00	1.93	3.87	2.62	5.50	1.13	0.90
82-206-01	82LF-206-01	1-1/4	1.25	2.37	4.75	2.87	5.50	1.38	0.96
82-207-01	82LF-207-01	1-1/2	1.50	2.60	5.25	3.37	8.00	1.63	1.09
82-208-01	82LF-208-01	2	2.00	3.01	6.03	3.68	8.00	2.13	1.34
82-209-01	82LF-209-01	2-1/2	2.50	3.62	7.25	5.14	9.38	2.63	1.47
82A-240-01	-	3	3.00	4.18	8.37	8.10	19.13	3.13	1.66
82A-24A-01	-	4	4.00	5.43	10.86	8.88	19.13	4.13	2.16

* Model 82LF suitable for soft soldering only.

www.apollovalves.com

Customer Service (704) 841-6000



BALL VALVES

Three-Piece Brazed Tube-End Valves

82-200/82-240 SERIES

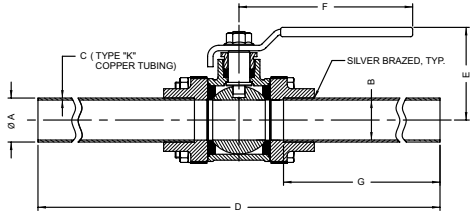

THREE-PIECE FULL PORT VALVE WITH BRAZED TUBE EXTENSIONS

This valve is useful in pharmaceutical, medical gas, pneumatic, and liquid applications where valves should not be disassembled prior to soldering or brazing.

FEATURES

- 6" type K copper tubing brazed into both end cup
- Rated 600 psig CWP, non-shock
- Optional gage port tapping
- Complies with NFPA99 and CGA G4.1
- Oxygen service option
- ASTM B584 Bronze
- SS ball and stem option

Nominal Tubing O.D.

Size (in.)	Standard Model No.	Standard Model No. 316 Ball & Stem	Oxygen Cleaned Model No.	Oxygen Cleaned Model No. 316 Ball & Stem	Dimensions (in.)						
					A	B	C	D	E	F	G
1/2	82-203-B8	82-243-A8	82-203-K1	82-243-K1	5/8	0.62	0.05	13.81	2.00	4.87	6.00
3/4	82-204-A8	82-244-B3	82-204-K1	82-244-K1	0.87	0.81	0.07	13.93	2.18	4.87	6.00
1	82-205-B7	82-245-B1	82-205-K1	82-245-K1	1.12	1.00	0.07	14.04	2.62	5.50	6.00
1-1/4	82-206-B7	82-246-B0	82-206-K1	82-246-K1	1.37	1.25	0.07	14.81	2.87	5.50	6.00
1-1/2	82-207-B2	82-247-B2	82-207-K1	82-247-K1	1.62	1.50	0.07	15.07	3.37	8.00	6.00
2	82-208-B7	82-248-B2	82-208-K1	82-248-K1	2.12	2.00	0.08	15.23	3.70	8.00	6.00
2-1/2	82-209-A2	82-249-A2	82-209-K1	82-249-K1	2.63	2.44	0.10	23.45	5.13	9.94	9.60
3	-	82A-240-A2	-	82A-240-K1	3.13	3.00	0.11	23.87	6.67	18.00	9.42
4	-	82A-24A-A0	-	82A-24A-K1	3.13	3.00	0.11	23.87	6.67	18.00	9.42

COMMERCIAL PRODUCTS CATALOG

Medical Gas Ball Valves - Outside the Zone Box

DESIGN: "F1", "F3", & "G3" CONFIGURATIONS

- Cast Bronze Valve Body & Valve End Caps
- RPTFE Seats and Stuffing Box Ring
- 600 psig CWP Non-Shock (3" & 4" 400 CWP)
- Vacuum Service to 29 inches Hg
- Full Port in All Sizes
- Blow-Out-Proof Stem Design
- Adjustable Packing Nut
- In-Line Repairable
- Locking Handle
- Cleaned for Oxygen Service per CGA G4.1 & NFPA 99
- Factory Brazed, Male Extensions for Solder or Brazed Installation without Disassembly (Type K copper tubing brazed into both end caps)

OUTSIDE THE ZONE BOX

NFPA 99 requires the valves to be secured in the open position. For medical gas applications that are Outside-the-Zone-Box, Apollo offers three standard configurations: "F1" (1 gage port), "F3" (2 gage ports), and "G3" (no gage ports).

82-200-F1 AND 82-240-F1 SERIES

MALE EXTENSIONS AND 1 GAGE PORT

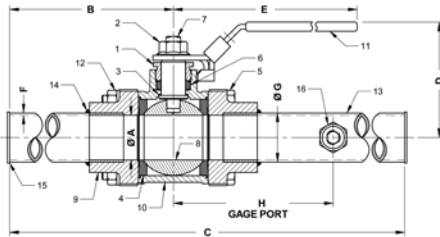

Size (in.)	82-200 Model Number	82-240 Model Number 316SS Ball & Stem	Dimensions (in.)							
			A	B	C	D	E	F	G	H
1/2	82-203-F1	82-243-F1	0.62	6.91	17.41	2.23	5.31	0.049	5/8"	7.15
3/4	82-204-F1	82-244-F1	0.81	6.97	17.47	2.41	5.31	0.065	3/4"	7.22
1	82-205-F1	82-245-F1	1.00	7.03	17.62	3.01	6.29	0.065	1-1/4"	7.28
1-1/4	82-206-F1	82-246-F1	1.25	7.38	22.71	3.22	6.29	0.065	1-3/8"	7.00
1-1/2	82-207-F1	82-247-F1	1.50	7.50	22.57	4.04	8.93	0.072	1-5/8"	6.74
2	82-208-F1	82-248-F1	2.00	7.74	22.58	4.15	8.93	0.083	2-1/8"	6.51
2-1/2	82-209-F1	82-249-F1	2.50	11.75	23.50	5.31	10.06	0.095	2-1/2"	6.38

82-200-F3 AND 82-240-F3 SERIES

MALE EXTENSIONS AND 2 GAGE PORTS

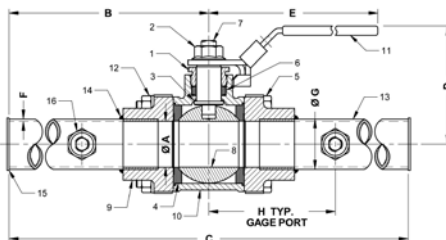

Size (in.)	82-200 Model Number	82-240 Model Number 316SS Ball & Stem	Dimensions (in.)							
			A	B	C	D	E	F	G	H
1/2	82-203-F3	82-243-F3	0.62	12.27	24.53	2.23	5.31	0.049	5/8"	4.25
3/4	82-204-F3	82-244-F3	0.81	12.25	24.50	2.41	5.31	0.065	3/4"	4.24
1	82-205-F3	82-245-F3	1.00	12.30	24.60	3.01	6.29	0.065	1-1/4"	4.24
1-1/4	82-206-F3	82-246-F3	1.25	12.23	24.46	3.22	6.29	0.065	1-3/8"	4.23
1-1/2	82-207-F3	82-247-F3	1.50	12.25	24.50	4.04	8.93	0.072	1-5/8"	4.25
2	82-208-F3	82-248-F3	2.00	12.25	24.50	4.15	8.93	0.083	2-1/8"	4.25
2-1/2	82-209-F3	82-249-F3	2.50	11.75	23.50	5.31	10.06	0.095	2-1/2"	6.38

BALL VALVES

Forged Brass Economy Valves

94A SERIES

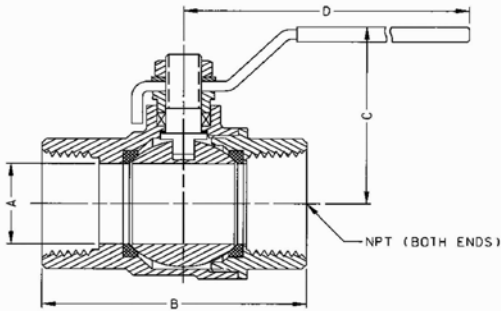
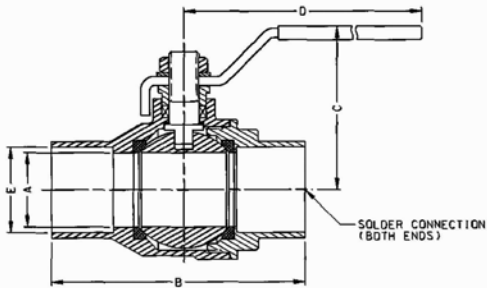

94A OPTIONS

Size	Replacement Handles	2-1/4" Stem Extension + Memory Stop
1/4"-3/8"	W932400	78217101
1/2"	W932500	78217201
3/4"	W936000	78217301
1"	W932600	78217401
1-1/4"	W932700	78217501
1-1/2"-2"	W932800	78217601
2-1/2"-3"	W932900	78217701
4"	W933000	78217801 ★ NEW

- Kits do not include stem nut

- Replacement handles are not UL marked

APOLLO INTERNATIONAL™ ECONOMY FULL PORT BALL VALVES

These full port ball valves with forged brass body are UL listed and CSA approved.

FEATURES

- Adjustable stem packing nut
- Meets MSS SP110 requirements
- 600 CWP non-shock (1/4" - 2")
- 400 CWP non-shock (2-1/2" - 4")
- 2-1/4" memory stop option
- 100% Factory Tested
- **Lead Free** option (94ALF-A)

APPROVALS

CSA listed (File # 226234) per the following standards:

- CAN 1-9.1 1/2 psig
- CGA 3.16 125 psig
- CGA CR91-002 5 psig
- ANSI Z21.15 1/2 psig
- ASME B16.44 5 psig
- ANSI/ASME B16.33 125 psig



UL listed

- Guides YQNZ, YRBX, YRPV, YSDT and MHKZ (1/4" - 4" NPT only)
- UL 258 - VQGU Trim & Drain 175# max (1/4" - 2")



FM 1140

* Gas approvals apply to NPT models only



Model Number	Size (in.)	Dimensions (in.)					Wt.
		A	B	C	D	E	
NPT							
94A-101-01	1/4"	0.395	1.746	1.840	3.543	-	0.33
94A-102-01	3/8"	0.407	1.756	1.840	3.543	-	0.30
94A-103-01	1/2"	0.583	2.047	1.921	3.543	-	0.44
94A-104-01	3/4"	0.748	2.362	2.087	3.780	-	0.66
94A-105-01	1"	0.945	2.756	2.559	4.528	-	1.10
94A-106-01	1-1/4"	1.260	3.307	2.953	4.528	-	1.57
94A-107-01	1-1/2"	1.575	3.661	3.346	5.512	-	2.40
94A-108-01	2"	1.969	4.181	3.681	5.512	-	3.37
94A-109-01	2-1/2"	2.520	5.378	4.764	8.661	-	7.60
94A-100-01	3"	2.953	6.039	5.079	8.661	-	9.36
94A-10A-01	4"	3.898	7.386	5.866	9.606	-	16.85
Solder							
94A-203-01	1/2"	0.583	2.047	1.839	3.543	0.630	0.38
94A-204-01	3/4"	0.748	2.748	1.996	3.780	0.878	0.64
94A-205-01	1"	0.945	3.228	2.441	4.528	1.130	0.99
94A-206-01	1-1/4"	1.260	3.819	2.854	4.528	1.378	1.40
94A-207-01	1-1/2"	1.575	4.425	3.169	5.512	1.630	2.17
94A-208-01	2"	1.969	5.315	3.449	5.512	2.130	2.97
94A-209-01	2-1/2"	2.520	6.283	4.764	8.661	2.630	6.36
94A-200-01	3"	2.953	7.150	5.079	8.661	3.130	8.32
94A-20A-01	4"	3.945	9.276	5.866	9.606	4.130	15.78



For additional information, submittal sheets and manuals, visit www.apollovalves.com

Customer Service (704) 841-6000

COMMERCIAL PRODUCTS CATALOG

Lead Free Forged Brass Economy Valves

94ALF-A SERIES



APOLLO INTERNATIONAL™ ECONOMY FULL PORT BALL VALVES

These Lead Free ball valves with forged DZR brass body are UL listed and CSA approved.

FEATURES

- Lead Free* materials and certification
- Solders like standard brass
- Distinctive white "Lead Free" handle grip and blue "Lead Free" hang tag
- 2-Piece, Full-Port design
- Blow-out Proof Stem
- Adjustable Stem Packing Nut
- Multiple agency approvals
- Valve Design Rating: 600 CWP – 1/4 to 2", 400 CWP – 2-1/2" to 4"
- Temperature Range: -20°F to 366°F
- 100% Factory Tested

APPROVALS

- MSS SP-110 - Ball Valves
- NSF/ANSI 61-G
- NSF/ANSI 372 Lead Free
- IAPMO IGC 157 (cUPC)
- ANSI Z21.15 (1/2 psi) (CSA 9.1) (1/4" – 2")
- ASME B16.44 (5 psi) (CR91-002) (1/4" – 2")
- ASME B16.33 (125 psi) (CGA 3.16) (1/4" – 2")
- **UL:** Guides YQNZ, YRBX, YRPV, YSDT and MHKZ (1/4" - 4" NPT only)
- UL 258 – VQGU Trim & Drain 175# max (1/4" – 2")
- FM 1140 (1/4" - 2" NPT & Solder)



Note: Gas approvals apply to NPT valves only

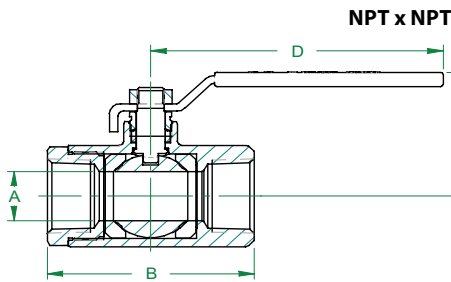

Solder x Solder

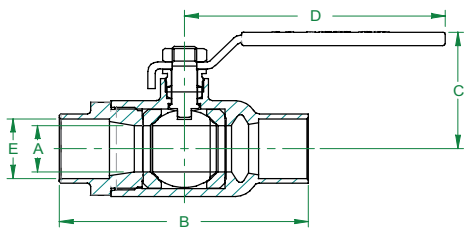

94ALF-A OPTIONS

Size	Replacement Handles	2-1/4" Stem Extension + Memory Stop
1/4"-3/8"	W234700	78217101
1/2"	W234800	78217201
3/4"	W234900	78217301
1"	W235000	78217401
1-1/4"	W235100	78217501
1-1/2"-2"	W235200	78217601
2-1/2"-3"	W235300	78217701
4"	W273800	78217801

- Replacement handles are not UL marked



LF Model Number	Size (in.)	Dimensions (in.)					Wt.
		A	B	C	D	E	
NPT							
94ALF-101-01A	1/4"	0.39	1.76	1.73	3.54	-	0.29
94ALF-102-01A	3/8"	0.39	1.76	1.73	3.54	-	0.30
94ALF-103-01A	1/2"	0.59	2.05	1.94	3.54	-	0.44
94ALF-104-01A	3/4"	0.75	2.36	2.11	3.78	-	0.71
94ALF-105-01A	1"	0.95	2.76	2.58	4.53	-	1.10
94ALF-106-01A	1-1/4"	1.26	3.31	2.96	4.53	-	1.63
94ALF-107-01A	1-1/2"	1.58	3.66	3.37	5.51	-	2.41
94ALF-108-01A	2"	1.97	4.18	3.70	5.51	-	3.66
94ALF-109-01A	2-1/2"	2.52	5.38	4.76	8.66	-	7.60
94ALF-100-01A	3"	2.95	6.04	5.08	8.66	-	9.60
94ALF-10A-01A	4"	3.90	7.39	5.86	9.61	-	21.00
Solder							
94ALF-203-01A	1/2"	0.59	2.05	1.84	3.54	0.63	0.40
94ALF-204-01A	3/4"	0.75	2.75	2.00	3.78	0.88	0.68
94ALF-205-01A	1"	0.95	3.23	2.45	4.53	1.13	1.15
94ALF-206-01A	1-1/4"	1.26	3.82	2.86	4.53	1.38	1.53
94ALF-207-01A	1-1/2"	1.57	4.43	3.17	5.51	1.63	2.31
94ALF-208-01A	2"	1.96	5.38	3.49	5.51	2.13	3.77
94ALF-209-01A	2-1/2"	2.52	6.28	4.76	8.66	2.63	6.79
94ALF-200-01A	3"	2.92	7.15	5.08	8.66	3.13	8.67
94ALF-20A-01A	4"	3.90	9.28	5.87	9.61	4.13	16.67

BALL VALVES

Lead Free APOLLOPEX Ball Valve

94XLF SERIES



BRASS PEX BALL VALVE

The Apollo® International 94XLF Lead Free* DZR forged brass ball valves combine reliable operation with maximum economy. Ideal for plumbing and heating applications including potable water. Valves are ANSI 3rd party Lead Free* certified and listed to NSF 14, NSF 61 and NSF 372.

FEATURES

- Lead Free* DZR materials and certification
- ASTM F1807 Pex design
- White Handle Grip identifies Lead Free construction
- Standard Port design
- Double O-ring stem seal
- Blow-out Proof Stem Design
- Silicone Free assembly

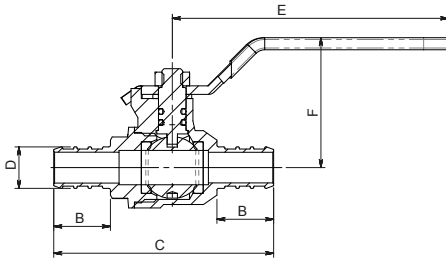

Model Number	Size (in.)	Dimensions (in.)					Wt. (lbs.)
		B	C	D	E	F	
94XLF-103-01	1/2	0.65	2.52	.47	3.17	1.49	.25
94XLF-104-01	3/4	0.65	2.62	.67	3.17	1.57	.41
94XLF-105-01	1	0.80	2.91	.86	3.17	1.57	.57

Stop & Waste Ball Valves

95ALF SERIES



FULL-PORT LEAD FREE BRASS BALL VALVE

The Apollo International™ 95ALF Lead Free forged DZR brass ball valves combine reliable operation with maximum economy. Ideal for plumbing or hydronic systems where draining is required. Valves are certified by IAPMO and ANSI 3rd party certified lead free.

FEATURES

- Lead Free materials and certification
- Blow-out proof stem design
- Adjustable stem packing nut
- Drain port with finger tight shut-off
- Fast, quarter-turn operation
- Valve Design Rating: 600 CWP
- Temperature Range: 32°F to 250°F
- IAPMO IGC157
- NSF/ANSI 61-G Water Quality
- NSF/ANSI 372 Lead Free

NPT x NPT

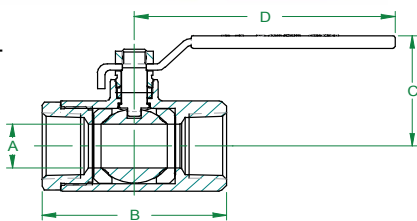

Solder x Solder

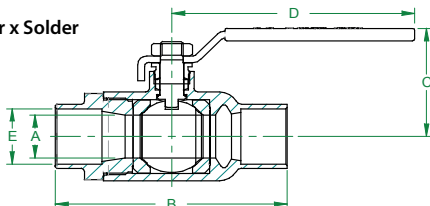

LF Model Number	Size (in.)	Dimensions (in.)				
		A	B	C	D	E
NPT						
95ALF-103-01	1/2	0.59	2.24	1.78	3.74	-
95ALF-104-01	3/4	0.79	2.53	2.09	3.94	-
95ALF-105-01	1	0.98	3.15	2.36	4.33	-
Solder						
95ALF-203-01	1/2	0.59	2.12	1.78	3.74	0.63
95ALF-204-01	3/4	0.79	2.87	1.94	3.94	0.88
95ALF-205-01	1	0.98	3.53	2.36	4.33	1.13



For additional information, submittal sheets and manuals, visit www.apollovalves.com

Customer Service (704) 841-6000

COMMERCIAL PRODUCTS CATALOG

Mini Ball Valves

94 MBV SERIES



MINI BALL VALVE – APOLLO INTERNATIONAL™

Designed for commercial and light industrial use. Conventional port, constructed of heavy-duty forged brass, PTFE seats and gland follower with double viton o-rings, to prevent stem leakage.

FEATURES

- Reversible handle
- Blowout-proof stem
- Double Viton o-ring stem seals
- Large raised wrench flats
- Chrome plated brass ball
- Maximum 600 psig at 100°F, non-shock
- Temps from -40°F to 300°F
- ANSI Z21.15-2009 / CSA 9.1-2009 (1/2 psi) Manually Operated Gas Valves for Appliances.
- ASME B16.44-2002 Manually Operated Metallic Gas Valves for use in Above Ground Piping Systems (2 and 5 psig).
- MSS-SP110 compliant

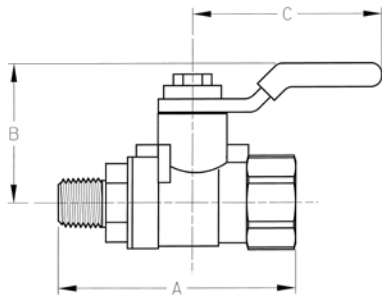

Model Number	Size (in.)	Dimensions (in.)			Port Ø	Wt. (lbs.)
		A	B	C		
94-MBV-01	1/4 FNPT x 1/8 MNPT	1.95	1.09	1.65	0.31	0.19
94-MBV-02	1/4 FNPT x 1/4 MNPT	1.95	1.09	1.65	0.31	0.20
94-MBV-03	1/4 FNPT x 1/4 FNPT	1.95	1.09	1.65	0.31	0.17
94-MBV-04	1/8 FNPT x 1/8 MNPT	1.95	1.09	1.65	0.31	0.16
94-MBV-05	1/8 FNPT x 1/8 FNPT	1.95	1.09	1.65	0.31	0.16

General Purpose Uni-Body Valves

9A-100 SERIES



HEAVY PATTERN UNI-BODY THREADED BALL VALVE

One piece bronze valve eliminates leak paths. Features static grounding devices and adjustable packing gland. Lever handle standard.

FEATURES

- Rated 600 psig CWP, non-shock
- 150 SWP
- Blowout-proof stem design

OPTIONS INCLUDE:

- Cam lock option (-30 suffix)
- Round handle option (-15 suffix)
- Latch lock handle option (-27 suffix)

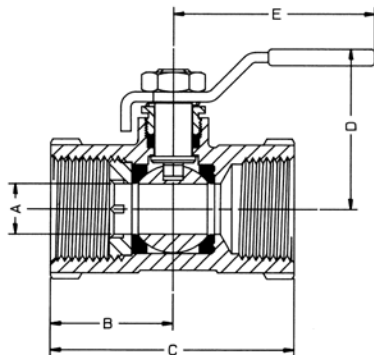

Model Number	Size (in.)	Dimensions (in.)				
		A	B	C	D	E
9A-101-01	1/4	0.37	1.34	2.59	1.68	3.87
9A-102-01	3/8	0.37	1.34	2.59	1.68	3.87
9A-103-01	1/2	0.37	1.34	2.59	1.81	3.87
9A-104-01	3/4	0.50	1.44	2.84	1.84	3.87
9A-105-01	1	0.62	1.72	3.28	2.00	4.87
9A-106-01	1-1/4	0.81	1.94	3.84	2.18	4.87
9A-107-01	1-1/2	1.00	2.06	4.00	2.68	5.50
9A-108-01	2	1.25	2.29	4.56	2.87	5.50

BALL VALVES

Versatile Iron Ball Valves (International)

IBV-125 SERIES (6P & 6Q SERIES)

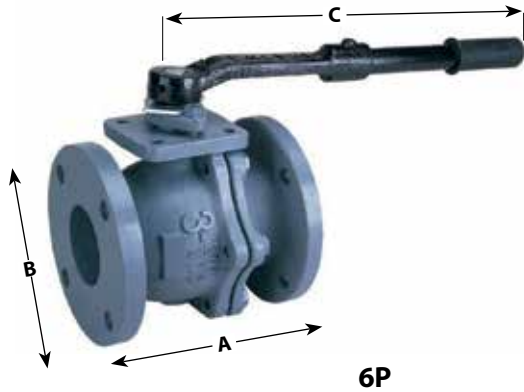

6P CAST IRON FULL PORT CLASS 125 FLANGED BALL VALVE

Meets MSS SP-72, ANSI B16.10 performance standards. Can be used to replace IBBM gate valve or plug valve. Low profile handle for easy installation in tight areas.

FEATURES

- 200 CWP/ 125 SWP
- 350° F max.
- Full port design in all sizes offers superior flow rate
- No bronze seat rings, disc rings or stems to wear out
- Quarter-turn operation offers instant, positive shut off with zero leakage
- Gear operator standard for 8" and 10"
- Stainless steel ball resists corrosion
- Handle indicates valve operation status
- Large actuator mounting pad standard
- Blowout-proof stainless steel stem
- PTFE seats and packing, not nitrile or EPDM



6Q EPOXY COATED DUCTILE IRON FULL PORT CLASS 125 FLANGED BALL VALVE

All of the same design and construction features of the 6P ductile iron construction plus an FDA-approved, heat fused epoxy coating. Rated 200 CWP @ 200°F.

IBV Model Number	IBVE Model Number	Size (in.)	Dimensions (in.)				Wt.
			A	B	C	D	
6P-208-01	-	2	7.00	6.00	9.00	3.00	22.0
6P-209-01	6Q-209-01	2-1/2	7.50	7.00	16.00	3.70	34.0
6P-200-01	6Q-200-01	3	8.00	7.50	16.00	4.00	38.0
6P-20A-01	6Q-20A-01	4	9.00	9.00	19.70	4.80	58.0
6P-20C-01	6Q-20C-01	6	10.50	11.00	26.00	7.20	118.0
6P-20E-01	-	8*	11.50	13.50	-	9.24	345.0
6P-20G-01	-	10*	13.00	16.00	-	11.81	440.0

* with manual gear operator

These valves are being discontinued. After current stock is depleted; this valve will be replaced by the Lead Free 6PLF Series. See page 52.

COMMERCIAL PRODUCTS CATALOG

Apollo International™ Cast Iron Ball Valve

6PLF SERIES



Now Available!

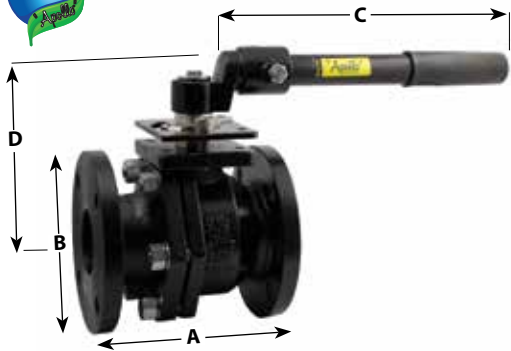

CAST IRON CLASS 125 FLANGED BALL VALVE

The cast iron/epoxy coated, Class 125 Apollo International™ 6PLF Series Lead Free* Ball Valves offer unobstructed turbulence-free flow that gate and butterfly valves can't match. Compact design and low profile handle for easy installation in tight areas.

FEATURES

- A126 Class B Cast Iron Body with FDA food-grade epoxy powder coat
- Stainless Steel Ball & Stem
- PTFE Seats
- ISO 5211 Mounting Pad for Easy Actuation
- Adjustable stem packing
- Full Port through 6"
- NSF/ANSI 61-G Water Quality
- NSF/ANSI 372 Lead Free
- 200 CWP/125 SWP
- Vacuum Service to 29" Hg

LF Model Number	Size (in.)	Dimensions (in.)				Wt.
		A	B	C	D	
6PLF-208-01	2	7.00	6.00	12.20	6.50	22.70
6PLF-209-01	2-1/2	7.50	7.00	13.78	7.42	36.73
6PLF-200-01	3	8.00	7.50	13.78	8.17	46.63
6PLF-20A-01	4	9.00	9.00	15.75	9.00	71.83
6PLF-20C-01	6	10.50	11.00	30.00	11.32	111.99
6PLF-20E-01*	8	11.50	13.50	30.00	11.32	210.54
6PLF-20G-01*	10	13.00	16.00	33.00	13.05	294.10

* Gear Operated

Gas/Fuel Shut-Off Valves

GB-10 SERIES



CSA GAS SHUT-OFF VALVES

Manual shut-off valves engineered specifically for low pressure gas service. Canadian Standard Association design and capacity certified with American-made quality. High-copper content body, chrome-plated ball, and PTFE seats.

FEATURES

- Complies with ANSI Z21.15, CR91-002, and ASME 16.44
- Use with natural, manufactured, mixed and liquefied petroleum gases, LP gas-air mixtures
- Temperature range: 32°F - 125°F at pressures of 1/2 and 5 psig
- Standard die-cast zinc "wing" handle (-01), epoxy coated
- Lever (-L1) or tee handle (-T1) options
- Made in USA

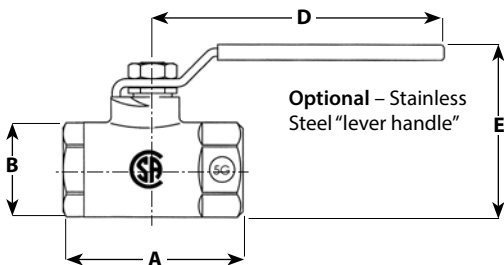
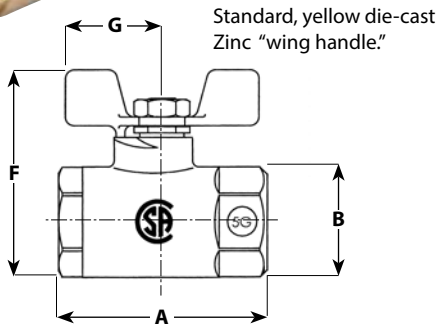

Model Number	Size (in.)	Connection	BTU/ Hr*	Dimensions (in.)						
				A	B	C	D	E	F	G
51GB-201	3/8	3/8 NPT	318,700	2.04	1.06	0.38	3.85	2.24	2.20	0.81
51GB-301	1/2	1/2 NPT	623,750	2.24	1.18	0.50	3.85	2.30	2.24	0.81
51GB-401	3/4	3/4 NPT	1,265,000	2.97	1.55	0.69	4.75	2.85	2.90	1.00
51GB-501	1	1 NPT	2,037,500	3.33	1.81	0.88	4.75	3.10	3.15	1.00

* Capacity based on a gas having a heating value of 1000 Btu/cubic feet and an S.G. of 0.64 at a P.D. of 1" W.C.

BALL VALVES

Gas Appliance Ball Valves – Apollo International™

GB-15 SERIES



GB-15

GAS BALL VALVE

Designed for natural gas, manufactured and mixed gas, liquefied petroleum gases and LP gas-air mixture applications.



APPROVALS

- ANSI Z21.15 (Appliance & Hose)/CGA9.1(1/2 psi)
- ASME B16.44 (5 psi)
- UL Guide YRBX (Flammable Liquid Shut-Off)
- UL Guide MHKZ (Manual Valves)
- UL Guide YRPV (Gas Shut-Off –250#)
- UL Guide YSDT (LP Gas)

Model Number	Part Number	Size & End Connection (in.)
GB-15	51GF301A	1/2 FNPT x 1/2 FNPT
GB-15	51GF401A	3/4 FNPT x 3/4 FNPT

5-Port Tank Selector

78-124/78-125 SERIES



5-PORT TANK SELECTOR

Unique ball design allows for higher flow capacities. Five port construction allows access to four tanks using only one valve.

FEATURES

- Five NPT connections
- Bronze ball valve with stainless steel Lever and Nut
- PTFE seats and RPTFE stem packing
- Stem packing adjustable for wear
- Non-lubricated
- 50 psig pressure rating
- Operation: four selected inlets feed one common outlet
- Pointer on handle indicates the selected inlet
- Easy mounting design

Series Number	Size (in.)	Dimensions (in.)								Wt./100 (lbs.)
		A	B	C	D	E	F	G	H	
78-124-01	1/2	0.50	1.26	2.52	2.27	3.53	1.12	10-24	1.40	106
78-125-01A	3/4	0.75	1.56	3.12	2.93	3.87	1.53	1/4-20	1.98	264

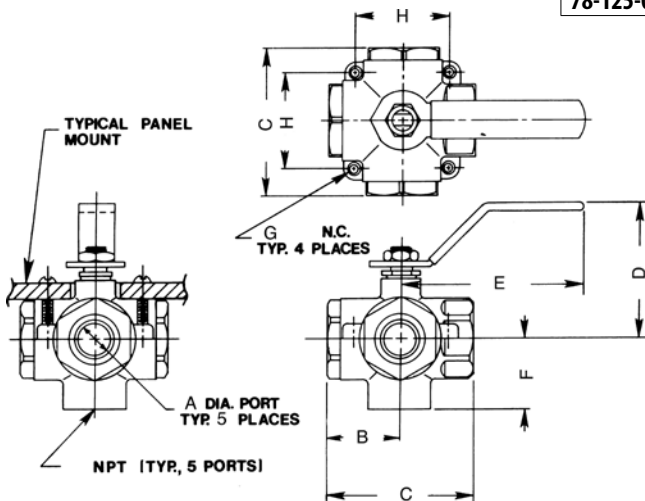

COMMERCIAL PRODUCTS CATALOG

Gas/Fuel Shut-Off Valves

GB-50 & GB-50A SERIES



GB-50



GB-50A



CSA GAS SHUT-OFF VALVES

Designed for indoor "main burner" applications with cast-in single or dual pilot tap. ASTM B584 bronze body, chrome-plated ball, brass stem, retainer and gland screws for corrosion resistance.

FEATURES

- For natural gas, manufactured and mixed Gas, liquefied petroleum gases and LP gas-air mixtures
- Rated pressures of 1/2 and 5 psig
- Standard connection is FNPT x FNPT
- High capacity
- Reversible plated steel lever handle. Optional "tee" handle (-07)

APPROVALS

- ANSI Z21.15, CGA9.1
- ASME B16.44 (2 and 5 psig)
- MSS-SP110
- UL Guide YRBX
- UL Guide MHKZ
- UL Guide YRPV
- UL Guide YSDT
- UL 125, UL 842

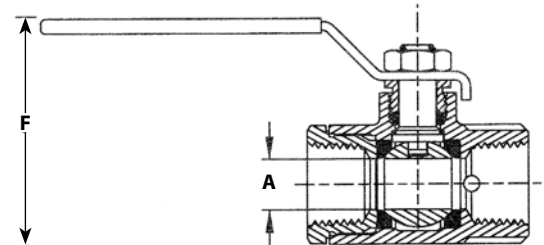
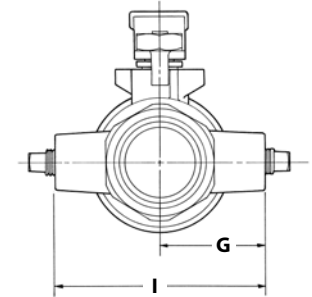
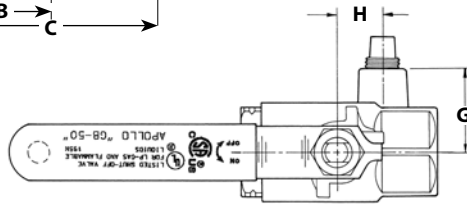
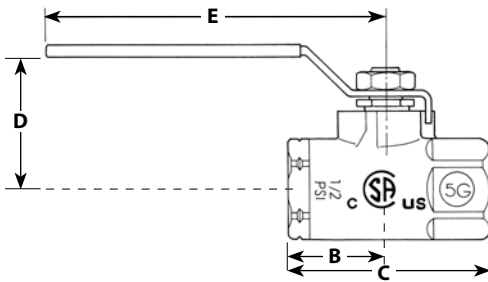

Model No. Single Tapped	Model No. Dual Tapped	Size (in.)	Tapping	Dimensions (in.)									Capacity BTU/Hr.
				A	B	C	D	E	F	G	H	I	
50GB-301	--	1/2	1/8	0.50	1.11	2.25	1.68	3.85	2.27	1.00	0.53	-	693000
50GB-401	50GB-401A	3/4	1/8	0.75	1.26	2.67	1.93	3.85	2.72	1.12	0.75	2.24	1258000
50GB-501	50GB-501A	1	1/8	1.00	1.65	3.42	2.19	4.78	3.18	1.53	0.94	3.06	3144000
50GB-601	50GB-601A	1-1/4	1/8	1.25	1.87	3.86	2.37	4.78	3.56	1.62	1.15	3.24	6441000
50GB-701	50GB-701A	1-1/2	1/8	1.50	2.05	4.22	2.81	5.40	4.21	1.81	1.31	3.62	7745000
50GB-801	50GB-801A	2	1/8	2.00	2.48	5.02	3.18	5.40	4.93	2.18	1.68	4.36	14741000
50GB-5A1	50GB-5A1A	1	1/4	1.00	1.65	3.42	2.19	4.78	3.18	1.53	0.94	3.06	3144000
50GB-6A1	50GB-6A1A	1-1/4	1/4	1.25	1.87	3.86	2.37	4.78	3.56	1.62	1.15	3.24	6441000
50GB-7A1	50GB-7A1A	1-1/2	1/4	1.50	2.05	4.22	2.81	5.40	4.21	1.81	1.31	3.62	7745000
50GB-8A1	50GB-8A1A	2	1/4	2.00	2.48	5.02	3.18	5.40	4.93	2.18	1.68	4.36	14741000

* Note: Capacities based on 1000 Btu/cubic feet gas at 0.64 specific gravity, at a P.D. of 1" W.C.



BUTTERFLY VALVES

BUTTERFLY VALVES

REV. 7/29/14



See Butterfly Valves Catalog (ABBR141G) for more detailed information about the products in this section.



BUTTERFLY VALVES

General Purpose Butterfly Valves – 141 & 145 Series

LD/WD 141 SERIES

APOLLO INTERNATIONAL™



WD 141
Wafer
2" – 12"



LD 141
Lug
2" – 24"

LD/WD 145 SERIES

MADE IN AMERICA



WD 145
Wafer
2" – 12"



LD 145
Lug
2" – 12"

The Apollo LD/WD Series ductile iron butterfly valves are ideal for use in industrial and HVAC/mechanical applications. The WD Series is a wafer style valve and the LD Series is a lug style.

FEATURES

- Compatible with ANSI 125# & 150# flanges
- ISO 5211 top plate allows choice of Apollo actuators and manual operators
- Conforms to MSS SP-67 & API 609
- LD141 and LD145 Series suitable for end of line service to rated pressure (2" - 12")
- 3"-24" meet performance requirements of AWWA C-504
- Certified NSF/ANSI 372 Lead Free
- Registered under Canadian Registration Number CRN# 0C12102.8CL

PRESSURE-TEMPERATURE RATING AT 100°F (37.8°C)

All Body, Disc, Seat Combinations

2"-12" (DN50 - DN300) 200 psi (13.8 bar)

14"-24" (DN350 - DN600) 150 psi (10.3 bar)

All Sizes – Vacuum Rating 29 inches of Hg

Torque Rating (in. lbs.)

Valve Size ¹		Full Rated Pressures (psig)			
Inches	DN	ΔP50	ΔP100	ΔP150	ΔP200
2	50	100	106	111	117
2.5	65	150	163	176	189
3	80	207	220	232	244
4	100	290	323	357	390
5	125	423	481	540	598
6	150	599	691	783	875
8	200	1060	1183	1307	1430
10	250	1671	1872	2074	2275
12	300	2568	2795	3023	3250
14	350	2640	3070	3500	N/A
16	400	4260	4880	5500	N/A
18	450	6287	7243	8200	N/A
20	500	8360	9180	10000	N/A
24	600	15427	16813	18200	N/A

¹ LD (2"-24"); WD (2"-12"); LC (2"-12")



See Butterfly Valves Catalog (ABBR141G) for more detailed information about the products in this section.

Customer Service (704) 841-6000

COMMERCIAL PRODUCTS CATALOG

General Purpose Butterfly Valves – 141 & 145 Series

LD MODEL

2" - 12"

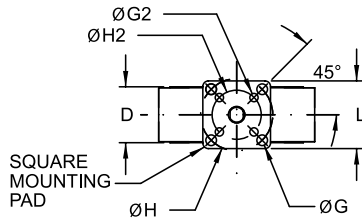

14" - 24"

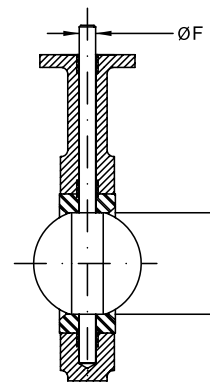
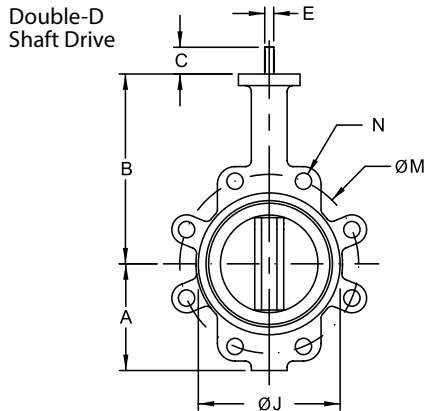
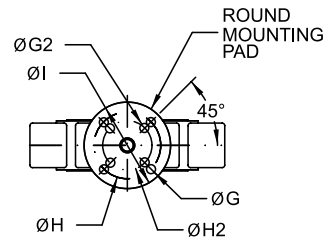

Shaft Drive:
Double-D (14")
Round & Keyed (16" & larger)

WD MODEL

2" - 12"

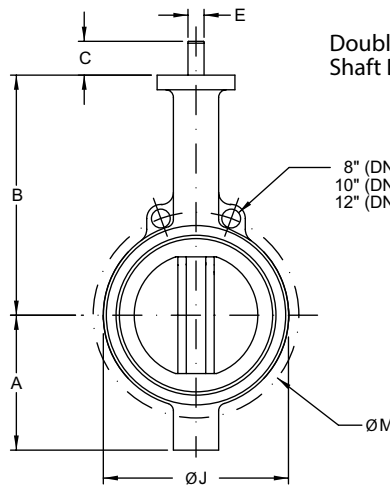
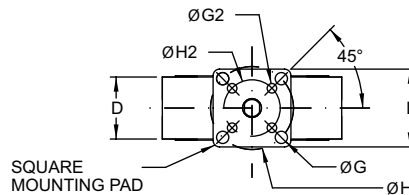

Double-D
Shaft Drive

8" (DN 200) : 2 HOLES, 0.98" DIAMETER
10" (DN 250) : 2 HOLES, 0.98" DIAMETER
12" (DN 300) : 2 HOLES, 0.98" DIAMETER

BUTTERFLY VALVES

General Purpose Butterfly Valves – 141 & 145 Series

Size Inches	Size DN	Dimensions in Inches – 141 & 145 Series								
		A	B	C	D	E	ØF	ØG	ØG2	Key
2	50	3.25	6.38	1.25	1.75	0.394	0.496	0.375	--	--
2-1/2	65	3.75	6.88	1.25	1.88	0.394	0.496	0.375	--	--
3	80	4.00	7.13	1.25	1.88	0.394	0.496	0.375	--	--
4	100	4.88	7.88	1.25	2.13	0.472	0.621	0.375	--	--
5	125	5.38	8.38	1.25	2.25	0.551	0.745	0.375	--	--
6	150	5.88	8.88	1.25	2.25	0.551	0.745	0.375	--	--
8	200	7.13	10.25	1.75	2.50	0.669	0.870	0.563	0.438	--
10	250	8.25	11.50	1.88	2.75	0.866	1.120	0.563	0.438	--
12	300	9.75	13.25	1.88	3.13	0.945	1.244	0.563	--	--
14	350	11.00	14.50	1.88	3.13	0.945	1.244	0.563	--	--
16	400	12.00	15.75	2.00	3.50		1.313	0.563	--	.313 sq
18	450	14.38	16.63	2.00	4.25		1.500	0.813	--	.375 sq
20	500	14.63	18.88	2.50	5.25		1.625	0.813	--	.375 sq
24	600	18.00	22.13	2.75	6.13		2.000	0.813	--	.500 sq

Size Inches	Dimensions in Inches – 141 & 145 Series								
	ØH	ØH2	ØI	ØJ	K	L	M	N (# Holes)	N (Tap UNC)
2	2.756	--	2.70	4.00	2.09	1.113	4.75	4	.625-11
2-1/2	2.756	--	2.70	4.75	2.54	1.706	5.50	4	.625-11
3	2.756	--	2.70	5.13	3.09	2.450	6.00	4	.625-11
4	2.756	--	2.70	6.75	4.09	3.488	7.50	8	.625-11
5	2.756	--	2.70	7.75	4.85	4.296	8.50	8	.750-10
6	2.756	--	2.70	8.63	6.13	5.697	9.50	8	.750-10
8	4.921	4.015	4.61	10.56	7.89	7.468	11.75	8	.750-10
10	4.921	4.015	4.61	13.06	9.89	9.484	14.25	12	.875-9
12	4.921	--	4.61	16.00	11.89	11.456	17.00	12	.875-9
14	4.921	--	Ø5.91	17.13	13.38	13.000	18.75	12	1.00-8
16	4.921	--	Ø5.91	20.00	15.38	14.970	21.25	16	1.00-8
18	6.496	--	Ø8.27	21.38	17.38	16.847	22.75	16	1.125-7
20	6.496	--	Ø8.27	23.31	19.38	18.650	25.00	20	1.125-7
24	6.496	--	Ø8.27	27.88	23.38	22.558	29.50	20	1.125-7

Approximate Weight for Bare Shaft Valve

Valve Size		WD Model Lbs (kg)	LD Model Lbs (kg)
Inches	DN		
2	50	6 (2.7)	8 (3.6)
2.5	65	6 (2.7)	10 (4.5)
3	80	7 (3.2)	11 (5.0)
4	100	11 (5.0)	17 (7.7)
5	125	13 (5.9)	20 (9.1)
6	150	16 (7.3)	23 (10.4)
8	200	29 (13.2)	39 (17.7)
10	250	44 (20.0)	62 (28.1)
12	300	70 (31.8)	97 (44.0)
14	350		148 (67.1)
16	400		206 (93.4)
18	450		277 (125.6)
20	500		410 (186.0)
24	600		592 (268.5)



See Butterfly Valves Catalog (ABBR141G) for more detailed information about the products in this section.

Customer Service (704) 841-6000

COMMERCIAL PRODUCTS CATALOG

Contractor Grade Butterfly Valves – 149 Series

LC-149 SERIES



APOLLO INTERNATIONAL™

The LC149 Series Cast Iron Butterfly Valves are ideal for use in Industrial and HVAC/Mechanical applications. The LC149 Series is a lug style valve designed to be economical yet full featured.

PERFORMANCE RATING

- Max Operating Pressure: 200 psi (13.8 bar)
- Temperature Range: -30°F (-34°C) to 275°F (135°C)
- Cast iron body, EPDM seats and aluminum bronze disc is standard

APPROVALS

- NSF/ANSI 372 Lead Free
- Registered under Canadian Registration Number CRN# 0C12102.8CL

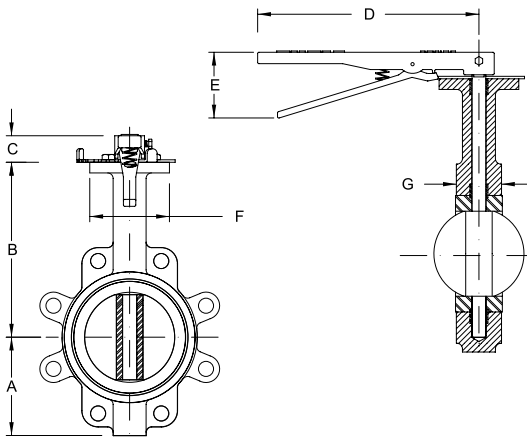

Size (in)	Dimensions in Inches – 149 Series with Handle						
	A	B	C	D	E	F	G
2	3.25	6.38	1.25	10.5	3.1	2.70	1.75
2-1/2	3.75	6.88	1.25	10.5	3.1	2.70	1.88
3	4.00	7.13	1.25	10.5	3.1	2.70	1.88
4	4.88	7.88	1.25	10.5	3.1	2.70	2.13
5	5.38	8.38	1.25	10.5	3.1	2.70	2.25
6	5.88	8.88	1.25	10.5	3.1	2.70	2.25
8	7.13	10.25	1.75	14.3	3.5	4.61	2.50
10	8.25	11.50	1.88	14.3	3.5	4.61	2.75
12	9.75	13.25	1.88	14.3	3.5	4.61	3.13

Size (in)	Dimensions in Inches – 149 Series with Optional Gear Operator									
	A	B	C	D	G	H	J	K	P	ØR
8	7.13	10.25	3.38	8.00	2.50	1.62	9.48	3.25	1.50	11.88
10	8.25	11.50	3.38	8.00	2.75	1.62	9.48	3.25	1.50	11.88
12	9.75	13.25	3.38	8.00	3.13	1.62	9.48	3.25	1.50	11.88

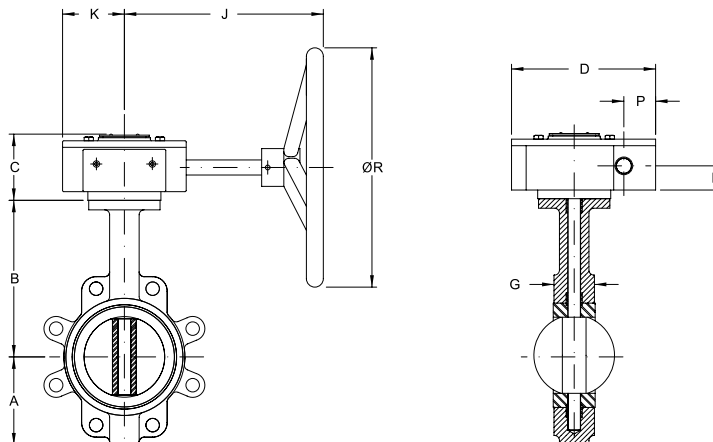

BUTTERFLY VALVES

How to Order WD and LD Butterfly Valves

CERTIFIED LEAD FREE NSF/ANSI 372 – MODEL NUMBER

WD	141	06	B	E	1	1	-S
MODEL	SERIES	SIZE (IN.)	DISC MATERIAL	SEAT MATERIAL	SHAFT	OPERATOR	
WD = Wafer Body (Ductile Iron) LD = Lug Body (Ductile Iron)	141 = Apollo International™ 145 = Assembled & Tested in USA	02 = 2" 25 = 2.5" 03 = 3" 04 = 4" 05 = 5" 06 = 6" 08 = 8" 10 = 10" 12 = 12" 14 = 14" 16 = 16" 18 = 18" 20 = 20" 24 = 24" 30 = 30"	B = Aluminum Bronze D = Ductile Iron A536 Nickel Plated S = Stainless Steel, CF8M	E = Black EPDM** -30° F to 275° F -34° C to 135° C N = Black BUNA-N** 10° F to 180° F -12° C to 82° C V = Black Viton® B † -15° F to 400° F -26° C to 204° C (145 Series Only) ** FDA Food Grade	1 = Std. 416 SS	0 = Bare Shaft 1 = 10 Position Handle 2 = Gear Operator - Direct Mount 3 = Infinite Position Handle 4 = Locking Handle 5 = Gear Operator w/ Chainwheel 7 = Locking Gear Operator 8 = Locking Gear Operator w/Chainwheel -S = Silicone Free Assembly (145 Series Only)	
	141 = Apollo International™ NOTE: LD-141 only						

NOTES:  • **Certification** - Product complies with NSF/ANSI 372 lead content requirements for "lead free" plumbing as defined by the U.S. Safe Drinking Water Act that took effect January 4, 2014. †

† Viton is primarily used for process applications, and has not been included in the scope of our Lead Free approvals

EXAMPLE:

WD141-06-BE-11: 6" WD141 Series, Ductile Iron Wafer Body, Aluminum Bronze Disc, Black EPDM Seat, 416 SS Shaft with 10 Position Handle

How to Order LC149 Butterfly Valves - Contractor Grade

CERTIFIED LEAD FREE NSF/ANSI 372 – MODEL NUMBER

LC149	06	1
SERIES	SIZE (IN.)	OPERATOR
LC149 = Cast Iron Lug Body Aluminum Bronze Disc 416 SS Shaft Black EPDM Seat	02 = 2" 25 = 2.5" 03 = 3" 04 = 4" 05 = 5" 06 = 6" 08 = 8" 10 = 10" 12 = 12"	1 = 10 Position Handle (2" - 12") 2 = Gear Operator (8" - 12" only)

NOTES:  • **Certification** - Product complies with NSF/ANSI 372 lead content requirements for "lead free" plumbing as defined by the U.S. Safe Drinking Water Act that took effect January 4, 2014.

EXAMPLE:

LC149-06-1: 6" LC149 Series, Cast Iron Body, Aluminum Bronze Disc, Black EPDM Seat, 416 SS Shaft with 10 Position Handle

Pricing

NOTE: Pricing of valves and options may be accessed through published Price List BFPL9000 or by Authorized Apollo Online users.



See Butterfly Valves Catalog (ABBR141G) for more detailed information about the products in this section.

Customer Service (704) 841-6000

REV. 8/8/14

COMMERCIAL PRODUCTS CATALOG





ACTUATION

ACTUATION



See Actuation Catalog (ACCA9000) for more detailed information about the products in this section.

ACTUATION

Pneumatic Actuators

AD and AS SERIES



APOLLO® RACK & PINION

Designed and manufactured for the ultimate in durability and reliability, the new Apollo® Pneumatic Rack & Pinion Actuators provide outstanding service life.

Apollo Rack & Pinion actuators have replaceable insert drive adapters in all but the largest models, and many units have dual "F" series bolt patterns. The numerous actuator drive and bolt pattern combinations allow direct mounting of several valve styles.

FEATURES

- **Cast Aluminum Body**
Yellow Chromate Powder Coat Finish
- **Die Cast Aluminum End Caps**
Yellow Chromate Powder Coat Finish
- **Die Cast Aluminum Pistons**
Yellow Chromate Coated
- **Aluminum Alloy Pinion**
7075-T6
Hard-coat Anodized Finish
- **Drive Inserts**
Extruded Aluminum
Hard-coat Anodized Finish
- **Preloaded Concentric Springs**
Deltatone® Coated
- **Piston Guides**
Molybdenum Disulfide filled Polyamide
- **Bushings**
Polyoxymethylene (POM)
- **O-Ring Seals**
Standard Temp. (-4°F to 180°F): Buna-N
High Temp. (-4°F to 250°F): Fluorocarbon
Low Temp. (-40°F to 180°F): Silicone
- **Cap screws, Nuts & Other Hardware**
304 Stainless Steel

COMMERCIAL PRODUCTS CATALOG

Automation Product

AE SERIES



Ruggedly built and designed for easy installation, new Apollo® AE Series electric actuators deliver the most standard features and performance in their class. *Now CSA listed all sizes as standard.*

FIVE OUTPUT TORQUES, ONE HOUSING

- 200, 400, 600, 800 and 1,000 inch-pounds
- Long Service Life
- Anodized die cast aluminum housing
- Fiberglass reinforced nylon cover resists corrosion
- Nitrile gasket and seals cover all penetration points in housing and cover
- Precision cut and heat treated alloy spur gears
- Permanently lubricated enclosed gear train
- NEMA 4, 4X

EASY TO USE

- Two separate 1/2" NPT conduit entrances for easier wiring and signal separation
- 12-position pre-wired terminal strip includes standard connections for remote open/closed position indicators; lots of room for wiring options
- Unrestricted mounting orientation
- Built-in thermal overload protection in all AC motor actuators
- Limit switches have an 11 amp rating at 115 VAC
- High visibility valve position indicator standard on all models

MANY STANDARD FEATURES

- Stainless steel push-and-turn manual override shaft, position indicator shaft and female output
- ISO 5211 F07 drive output reduces inventory of mounting kits
- 115 AC & 220 AC models feature a 25% duty cycle below 100°F (24AC — 20% duty cycle below 100°F)
- 12 and 24 DC — all DC voltage models provide 100% duty cycle for 1 hour after which DC motor is reduced to 80% duty cycle.
- Reversible rotation

BROAD TEMPERATURE RANGE

- Operates from -40°F (when equipped with 15 watt heater and thermostat) to 150°F

ACTUATION

Actuator Accessories

ACCESSORIES

VALVE POSITION MONITORS, SOLENOIDS, AND POSITIONERS



VALVE POSITION MONITORS

Here's the ultimate in valve monitoring: Position monitors feature a high visibility, color-coded indicator to display valve position. All monitors are designed to correspond to the latest NAMUR standard for actuator/position monitoring units. Plated steel or stainless steel mounting kits are available to provide a pre-engineered mounting solution for maximizing position monitor performance and direct mounting to actuators. Other brands also available. See our Actuator Catalog for details.



SOLENOIDS

Apollo® actuators can be supplied with solenoids manufactured by AVC (Automatic Valve Company). Our 3/4 way, field convertible, direct mount (NAMUR pattern) solenoid valves feature a variety of interchangeable integrated molded coils. They're compatible with both spring return and double acting actuators.



POSITIONERS

Apollo valve positioners are excellent tools for increasing the gain of your valve package, often reducing your actuator size due to your increased ability to accurately control higher air deliveries, and the flexibility to add options and accessories to complete your control package's performance.

Their simple design makes PMV positioners (shown here) easy to understand, calibrate and repair. Rugged construction provides operation in a variety of tough applications. Compact size minimizes space requirements. A complete package means the user can select the right positioner for his application. A bright indicator makes it easy for operators to visually check the valve position. Spool valve design requires very little maintenance. The electro-pneumatic unit eliminates the need for an extra product and additional connections. PMV positioners are proven products recognized for providing years of reliable service. Other brands are also available from your Apollo distributor.

Apollo offers both pneumatic and electro-pneumatic positioners as standard. Pneumatic positioners may be used on either double acting or spring return actuators. The anodized aluminum housing provides excellent product integrity and good corrosion resistance. Options include special coatings, stainless steel housings and a variety of accessory items which can help you meet your most demanding control applications. See our Actuator Catalog for complete details.

COMMERCIAL PRODUCTS CATALOG





SAFETY & RELIEF VALVES

SAFETY & RELIEF VALVES



See Safety & Relief Valve Catalog (SRCA9000) for more detailed information about the products in this section.



SAFETY & RELIEF VALVES

Hot Water Relief Valves

RVW 10 (10) SERIES



SECTION IV ASME HOT WATER RELIEF VALVES

These capacity-certified relief valves protect against excessive water pressure (from thermal expansion) and steam generated when Btu input controls fail. Valves comply with ASME Section IV requirements. Ideal for use with hot water boilers and heating systems.

FEATURES

- Pressures from 20 to 150 psig
- Brass or bronze body available with optional satin or polished chrome finish
- Maximum temperature service: 250°F
- 10-321 in polished chrome only
- Stainless steel springs
- 10-624/634 are high capacity safety relief valves ideal for OEM applications
- 10-418/417 are ideal for use in swimming pool heater applications
- Registered in all Canadian Provinces and Territories, CRN #0G8547.5C



10-102
10-303



10-104
10-301



10-321



10-407(30#)
10-417



10-408 (30#)
10-418



10-624
(Male inlet)
10-634
(Female inlet)

Series Number	Size (in.)		Certified Pressure Range psig	Height (in.)	Wt./100 (lbs.)	*Certified Capacity			
	Inlet NPT	Outlet NPT				30 psig	40 psig	50 psig	75 psig
10-102	3/4 F	1 F	20-60	3.31	105	710,000	870,000	1,035,000	-
10-104	3/4 M	1 F	20-60	3.75	109	710,000	870,000	1,035,000	-
10-301	3/4 M	3/4 F	20-60	3.75	114	550,000	675,000	805,000	-
10-303	3/4 F	3/4 F	20-60	3.31	115	550,000	675,000	805,000	-
10-321	3/4 M	3/4 F	20-60	3.75	123	425,000	525,000	625,000	-
10-407	3/4 M	3/4 F	30	3.00	62	535,000	-	-	-
10-408	3/4 F	3/4 F	30	2.75	65	535,000	-	-	-
10-417	3/4 M	3/4 F	20-80	3.00	62	477,000	587,000	697,000	972,000
10-418	3/4 F	3/4 F	20-80	2.75	65	477,000	587,000	697,000	972,000

* National Board Capacity Certified – BTU Per Hour (90% of actual capacity at 10% accumulation). ASME boiler and pressure vessel code – Section IV – Heating Boilers

Series Number	Size (in.)		Certified Pressure Range psig	Height (in.)	Wt./100 (lbs.)	*Certified Capacity				
	Inlet NPT	Outlet NPT				30 psig	75 psig	100 psig	125 psig	150 psig
10-624	3/4 M	3/4 F	30-150	4.62	106	689,000	1,405,000	1,802,000	2,199,000	2,597,000
10-634	3/4 F	3/4 F	30-150	4.62	106	689,000	1,405,000	1,802,000	2,199,000	2,597,000

Note: To order 10-620 series add pressure set point to the end of base number (i.e. 10624150=150 psig).

SUFFIX KEY (Excluding 10-624 and 10-634)

Pressure psig	Plain Brass	Satin Chrome	Polished Chrome
20	-02	-41	-67
22	-03	-42	-68
25	-04	-43	-69
30	-05	-44	-70
35	-06	-45	-71
40	-07	-46	-72
43	-08	-47	-73
45	-09	-48	-74
50	-10	-49	-75
55	-11	-50	-76
60	-12	-51	-77

Note: When ordering, specify pressure and finish by adding the two digit suffix after the product number, i.e. 10-102-05: 3/4" FNPT x 1" FNPT at 30 psig with plain brass finish.

COMMERCIAL PRODUCTS CATALOG

Safety Valves

RVS 32 & RVS 52 (10-322, 10-512) SERIES



10-512



10-322

ASME SECTION VIII STEAM SAFETY VALVES

National Board capacity certified safety valves; brass body with optional satin or polished chrome finish. Protects against excess pressure from thermal expansion and steam caused by failure of BTU input controls. Ideally suited for OEM applications such as steam cookers, autoclaves, sterilizers, coffee makers and similar equipment.

FEATURES

- Pressure settings 15 to 60 psig
- Discharge capacities to 725 lbs./hr.
- Stainless steel springs
- 10512 - Silicone soft seat for tight shut-off
- 10322 - EPDM soft seat for tight shut-off
- Registered in all Canadian Provinces and Territories, CRN #0G8547.5C

Series Number	Size (in.)		Pressure Range psig	Height	Wt./100 (lbs.)
	Inlet NPT	Outlet NPT			
10-322	3/4 M	3/4 F	20-60	3.75	128
10-512	1/2 M	1/2 F	15-60	2.62	58

MODEL NUMBERING SYSTEM

10 - X	-X	-XX	-X
MODEL AND SIZE (IN.)	FINISH	SET PRESSURE	OPTIONS
512 = 1/2 x 1/2	B = Plain Brass S = Satin Chrome P = Polished Chrome	Set Pressure in PSIG (2 Digits)	CE = PED/CE S = Stainless Steel trim V = Viton® Seat
322 = 3/4 x 3/4			

ASME Section IV Low Pressure Steam Safety Valves

RVS 14 (14-200) SERIES

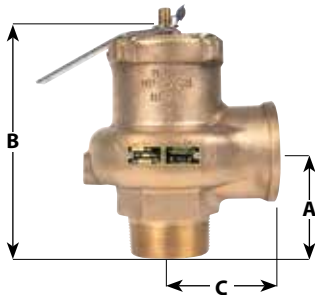

HIGH CAPACITY LOW PRESSURE STEAM BOILER SAFETY VALVES

National Board capacity certified in accordance with ASME Section IV at 15 psig. For commercial and industrial boilers. Capacities up to 6843 lbs./hr.

FEATURES

- EPDM o-ring for positive seal
- One piece body, all bronze construction
- PTFE coated piston
- Chrome plated Bronze body seat
- Optional test gag available for hydrostatic testing (add "G" suffix)
- Registered in all Canadian Provinces and Territories, CRN #0G8547.5C

Series Number	Size (in.)	*Capacity lbs./hr.	Dimensions (in.)			Wt./100 (lbs.)
			A	B	C	
14-205-08	2 x 2	3150	3.00	7.12	3.12	8.4
14-206-08	2-1/2 x 2-1/2	4676	3.50	8.25	3.50	13.0
14-207-08	3 x 3	6843	4.12	9.37	3.87	17.0

* National Board Capacity Certified at 15 psig. (90% of actual capacity at 33% accumulation.)

Note: When ordering specify pressure by adding the two digit key number after the part number as follows: 5 psig - 03; 6 psig - 04; 8 psig - 05; 10 psig - 06; 12 psig - 07; 15 psig - 08

SAFETY & RELIEF VALVES

Hot Water Relief Valves

RVW 60/61 (10-600) SERIES



SECTION IV ASME HOT WATER RELIEF VALVES

High-capacity heating valves with female inlet, expanded or standard female outlet. Protects against excessive water pressure due to failure of controls to regulate BTU input. Elevated seat for drainage of water away from seat area. Entire pressure range is National Board capacity certified.

FEATURES

- High BTU capacity rating
- Silicone seat
- Fabric reinforced molded diaphragm isolates spring from water at all times
- Bronze body and spring cage
- Maximum temperature service 250°F
- Registered in all Canadian Provinces and Territories, CRN #0G8547.5C

Series Number	Size (in.)		Certified Pressure Range psig	Wt./100 (lbs.)	Dimensions (in.)		
	Inlet NPT	Outlet NPT			A	B	C
10-604	3/4F	3/4F	15-160	232	1.03	5.25	1.62
10-605	1F	1F	15-160	410	1.25	6.69	2.00
10-606	1-1/4F	1-1/4F	15-160	795	1.25	8.37	2.47
10-607	1-1/2F	1-1/2F	15-160	1100	2.00	10.75	2.75
10-608	2F	2F	15-160	2375	2.19	14.00	3.69
10-614	3/4F	1 F	15-160	226	1.03	5.25	1.72
10-615	1 F	1-1/4F	15-160	390	1.25	6.69	2.00
10-616	1-1/4F	1-1/2F	15-160	755	1.25	8.37	2.47
10-617	1-1/2F	2F	15-160	1145	2.00	10.75	2.75
10-618	2F	2-1/2F	15-160	2315	2.19	14.00	3.66

Use Suffix No. to designate last two digits of Product No. for desired pressure. Other pressure settings available upon request.

BTU/HR at 10% over-pressure. National Board Certified. Ratings are 90% of actual at 10% accumulation.

Pressure psig	Suffix Number	3/4 x 3/4 10-604	1 x 1 10-605	1-1/4 x 1-1/4 10-606	1-1/2 x 1-1/2 10-607	2 x 2 10-608
30	-05	827,000	1,339,000	2,316,000	3,151,000	5,193,000
50	-10	1,209,000	1,956,000	3,384,000	4,604,000	7,589,000
60	-12	1,399,000	2,265,000	3,918,000	5,331,000	8,786,000
75	-15	1,686,000	2,728,000	4,720,000	6,421,000	10,583,000
100	-20	2,162,000	3,500,000	6,055,000	8,238,000	13,577,000
125	-25	2,639,000	4,272,000	7,390,000	10,054,000	16,571,000
150	-34	3,116,000	5,044,000	8,725,000	11,871,000	19,565,000

Pressure psig	Suffix Number	3/4 x 1 10-614	1 x 1-1/4 10-615	1-1/4 x 1-1/2 10-616	1-1/2 x 2 10-617	2 x 2-1/2 10-618
30	-05	970,000	1,570,000	2,716,000	3,696,000	6,091,000
50	-10	1,418,000	2,295,000	3,969,000	5,400,000	8,900,000
60	-12	1,641,000	2,657,000	4,596,000	6,252,000	10,305,000
75	-15	1,977,000	3,200,000	5,535,000	7,531,000	12,412,000
100	-20	2,536,000	4,105,000	7,101,000	9,661,000	15,924,000
125	-25	3,096,000	5,011,000	8,668,000	11,792,000	19,435,000
150	-34	3,655,000	5,916,000	10,234,000	13,923,000	22,947,000

Other pressure settings available upon request.

COMMERCIAL PRODUCTS CATALOG

Low Pressure Steam Safety Valves

RVS 12 (12-200) SERIES

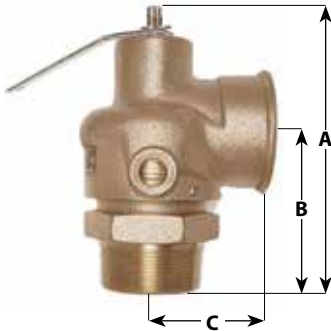

ASME SECTION IV

LOW PRESSURE STEAM HEATING BOILER SAFETY VALVES

Use on commercial steam heating boilers. National Board capacity certified at 15 psig.

FEATURES

- TFE coated EPDM seal
- All bronze construction
- 3/8" NPT side tapping for drain
- Top guided seat alignment
- Registered in all Canadian Provinces and Territories, CRN #0G8547.5C

Series Number	Size (in.)		Max. Pressure psig	Capacity* lbs./hr.	Wt./100 (lbs.)	Dimensions (in.)		
	Inlet NPT	Outlet NPT				A	B	C
12-205	2	2	15	2500	514	6.00	3.75	2.62
12-206	2-1/2	2-1/2	15	3529	835	8.50	5.25	3.06
12-208	3	3	15	4100	1162	9.50	6.00	3.75

Note: When ordering specify pressure by adding the two digit key number after the product number as follows: 5 psig - 03; 6 psig - 04; 8 psig - 05; 10 psig - 06; 12 psig - 07; 15 psig - 08

* National Board Capacity Certified-(15 psi rating, 90% of actual capacity at 33% accumulation.)

Low Pressure Steam Safety Valves

RVS 13 (13) SERIES

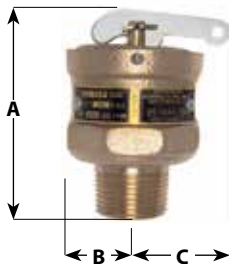

13-101



ASME SECTION IV

LOW PRESSURE STEAM HEATING BOILER SAFETY VALVES

National Board capacity certified at 15 psig in accordance with ASME Section IV; positive drainage of condensate from seat area.

FEATURES

- Flat seat, EPDM disc for positive seal
- Standard set pressure of 15 psig, capacities apply to valves set at 15 psig
- No. 13-101 is top outlet discharge
- Registered in all Canadian Provinces and Territories, CRN #0G8547.5C
- Rough Chrome option
- Non-code air service option (-A suffix)

Series Number	Size (in.)		Pressure psig	Max. Capacity* lbs./hr.	Wt./100 (lbs.)	Dimensions (in.)		
	Inlet NPT	Outlet NPT				A	B	C
13-101-B15	3/4 M	Top	15	410	64	2.87	0.94	1.250
13-211-B15	3/4 M	3/4 F	15	475	107	1.81	3.69	1.437
13-202-B15	1 M	1 F	15	643	110	2.06	3.87	1.218
13-213-B15	1-1/4 M	1-1/2 F	15	1200	218	2.53	4.50	1.875
13-214-B15	1-1/2 M	2 F	15	1900	320	3.00	5.25	2.187
13-511-B15	3/4 M	3/4 F	15	407	62	1.69	3.25	1.187
13-512-B15	3/4 F	3/4 F	15	407	59	1.81	2.75	1.187

* National Board Capacity Certified at 15 psig (90% of actual capacity at 33% accumulation.)

Notes: 1) Pressure settings available: 5 to 15 psig in 1 psig increments

2) Per ASME Code Section IV only 15 psi settings are "HV" and "NB" stamped

PART NUMBERING SYSTEM

13 -	XXX	-X	-XX	-X
SERIES	FINISH	SET PRESSURE	OPTIONS	
101 =	3/4" M x Top	B = Plain Brass S = Satin Chrome*	Set Pressure in PSIG (2 Digits)	A = Air Service (Non-ASME)
211 =	3/4" M x 3/4" F			
202 =	1" M x 1" F			
213 =	1-1/4" M x 1-1/2" F			
214 =	1-1/2" M x 2" F			
511 =	3/4" M x 3/4" F			
512 =	3/4" F x 3/4" F			

* Available on select models only

www.apollovalves.com

Customer Service (704) 841-6000



SAFETY & RELIEF VALVES

Relief Valves

RVA 14 (14-400/500) SERIES

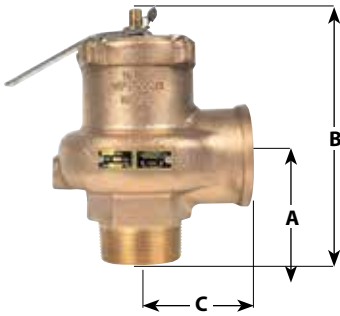

14-400
W/LIFT LEVER

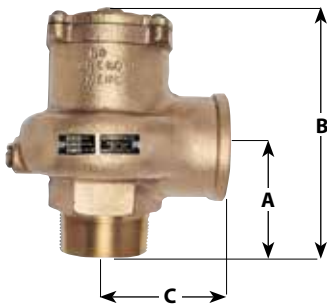

14-500
PLAIN CAP

NON-CODE AIR RELIEF VALVES

High volume air relief valves designed for non-ASME code low pressure air and gas service. Rugged bronze construction features elastomer soft seating and TFE coated discs. Standard test lever for model 14-400 and optional plain cap, weather resistant sealed body for model 14-500.

FEATURES

- Vibration resistant soft seat standard
- Stainless steel spring
- One piece unified bronze body design
- High flow "top-guided" design
- Inlet sizes 2", 2-1/2", and 3"
- Set pressures 4 to 22 psig @ 400°F max
- Compact end to end dimension

Series Number	Size (in./mm.)	Dimensions (in./mm.)			Wt./Ea. (lbs./kg.)
		A	B	C	
14-X05	2 x 2	3	6-1/2	3-1/8	8.4
	50M x 50F	76	165	79	3.81
14-X06	2-1/2 x 2-1/2	3-1/2	7-5/8	3-1/2	12.5
	65M x 65F	89	194	89	5.7
14-X07	3 x 3	4-1/8	8-3/4	3-7/8	17.0
	80M x 80F	105	222	98	7.7

PART NUMBERING SYSTEM

14	-X	-XX	-X
SERIES NUMBER	BODY/CAP STYLE AND SERVICE	INLET CONNECTION	RELIEF PRESSURE
14 = Base Model No.	4 = Air Relief, with Test Lever 5 = Air Relief, Plain Cap	05 = 2" NPT 06 = 2 1/2" NPT 07 = 3" NPT	Set Pressure in PSIG (2 Digits)

COMMERCIAL PRODUCTS CATALOG

Vacuum Relief Valves

RVV 14 (14-600) SERIES

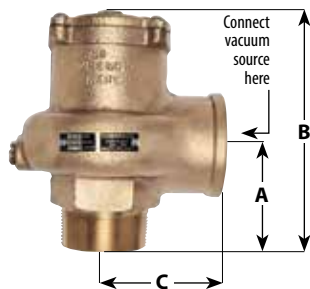

14-600

VACUUM RELIEF VALVES

High flow vacuum relief valves feature one piece cast bronze bodies, teflon coated discs and elastomer soft seating provide accurate and dependable operation. Ideal for use with high volume vacuum systems, bulk hauling tanks and trailers, powdered solids/bulk handling and pneumatic conveying equipment.

FEATURES

- Weather resistant construction
- Elastomer soft seat is vibration resistant
- Stainless steel spring
- One piece unified bronze body design
- High capacity "top-guided" design
- TFE/chrome plated internals
- Connection sizes 2", 2-1/2", and 3"
- Relief settings 8" to 30" Hg @ 400°F max

Series Number	Size (in./mm.)	Dimensions (in./mm.)			Wt./Ea. (lbs./kg.)
		A	B	C	
14-605	2 x 2	3	6-1/2	3-1/8	8.4
	50M x 50F	76	165	79	3.81
14-606	2-1/2 x 2-1/2	3-1/2	7-5/8	3-1/2	11.8
	65M x 65F	89	194	89	5.4
14-607	3 x 3	4-1/8	8-3/4	3-7/8	16.3
	80M x 80F	105	222	98	7.4

SERIES NUMBERING SYSTEM

14	-6	-0X	-VXX
SERIES NUMBER	BODY/CAP STYLE AND SERVICE	INLET CONNECTION	RELIEF PRESSURE
14 = Base Model No.	6 = Vacuum Relief	05 = 2" NPT 06 = 2 1/2" NPT 07 = 3" NPT	XX = Inches of Mercury

SAFETY & RELIEF VALVES

Safety Valve

RVA 15 (15-100) SERIES



ASME SECTION VIII SAFETY VALVES

ASME Air Relief Valves

FEATURES

- National Board Certified 15 psig through 250 psig
- Stainless steel springs
- High performance molded Viton seat design, Sizes 1/4" to 1/2"
- Viton o-ring seat, 3/4" & 1"
- Registered in all Canadian Provinces and Territories: CRN #0G8547.5C
- Maximum temp. 325°F
- ASTM B16 brass body
- Optional dual ASME/European Pressure Equipment Directive Compliance
- Manufactured in USA

National Board Certified capacities for air and gas service in air compressors, air receivers and gas lines

Series Number	Inlet Size (in.)	Dimensions (in.)		Wt./100 (lbs.)
		A	B	
15-112	1/4 NPT	2.625	.78	18.5
15-115	3/8 NPT	3.250	1.125	42.2
15-117	1/2 NPT	3.375	1.125	45.3
15-118	3/4 NPT	4.062	1.218	58.0
15-119	1 NPT	5.125	1.875	153.0

Set Pressure psig*	Capacities in SCFM @ 10% Accumulation			
	15-112 1/4"	15-115 & 117 3/8" or 1/2"	15-118 3/4"	15-119 1"
15	24	60	107	222
30	35	88	156	323
50	51	128	229	473
75	72	179	319	659
100	92	230	409	845
125	112	281	499	1032
150	133	332	589	1218
165	145	363	644	1330
175	153	383	680	1405
200	173	432	770	1591
225	194	484	860	1778
250	214	535	950	1964

* Other set pressures available upon request.

SERIES NUMBERING SYSTEM

15-XXX	-X	-XXX	-XX
SIZE (IN.)	FINISH	SET PRESSURE	OPTIONS
112 = 1/4 NPT 115 = 3/8 NPT 117 = 1/2 NPT 118 = 3/4 NPT 119 = 1 NPT	B = Plain Brass	Set Pressure in PSIG (15-250 psig)	CE = PED/CE Q = Performance (Calibration) Test Reports

COMMERCIAL PRODUCTS CATALOG

Pressure Relief Valves

RVW 16 (16-200) SERIES

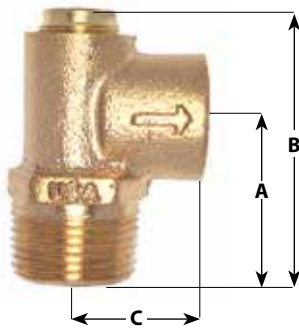

16-200

PRESSURE RELIEF VALVES

Pressure relief valves relieve excess pressure in cold water supply systems, storage tanks, and well pumps. Also suitable for air, oil, and other non-hazardous liquids.

FEATURES

- Cast bronze body, stainless steel springs
- Standard pressure settings from 50 to 175 psig
- All valves are 100% factory tested
- Silicone soft seat ensures seat tightness, extended service life
- Maximum recommended service temperature 120°F

Series Number	Inlet Size (in.)	Dimensions (in.)			Wt./100 (lbs.)
		A	B	C	
16-202	1/2 M x 1/2 F	1.41	2.12	1.00	33.0
16-203	3/4 M x 1/2 F	1.41	2.50	1.00	37.5

Note: When ordering, specify pressure by adding the two digit suffix after the product number, i.e.: 50 psig: -01; 75 psig: -02; 100 psig: -03; 125 psig: -04; 150 psig: -05; 175 psig: -06

16-501 SERIES

LEAD FREE OPTION COMING SOON!

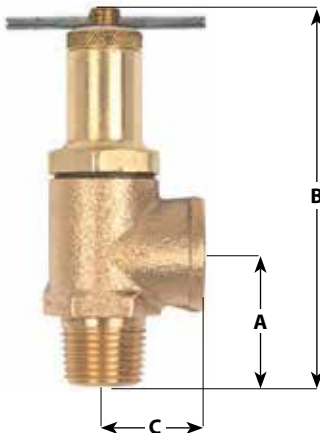

BY-PASS RELIEF VALVES

Adjustable relief valves protect equipment by providing low volume liquid relief or bypass control. Excess volume may be discharged back to the low pressure source. Ideal for agricultural sprayers and simple commercial or industrial pressurized systems.

FEATURES

- Adjustable relief settings, in two ranges to 600 psi
- Cast bronze body, stainless steel springs
- Choice of Nitrile (Buna) or PTFE soft seats
- Knurled locknut locks pressure adjustment
- Viton stem seal, polypropylene body gasket
- Maximum recommended service temperature 120°F

Series Number	Size (in.)	Relief Range	Seat Material	Wt./100 (lbs.)
16-501-01	1/2 M x 1/2 F	50 - 250	Nitrile	0.62
16-501-02	1/2 M x 1/2 F	250 - 600	Nitrile	0.62
16-501-25	1/2 M x 1/2 F	50 - 250	PTFE	0.62
16-501-60	1/2 M x 1/2 F	250 - 600	PTFE	0.62

16-503 & 16-504 SERIES

LEAD FREE OPTION COMING SOON!

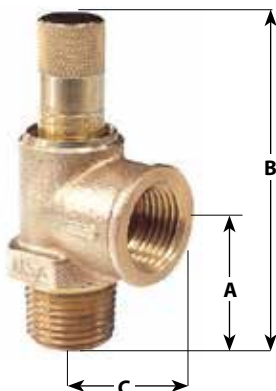

CALIBRATED PRESSURE RELIEF VALVES

Allows for in-line pressure adjustments without the need for a pressure gauge. Provides static overpressure protection for liquid filled systems such as well pumps, tanks, and fire protection systems.

FEATURES

- 1/2" or 3/4" inlet connection
- Factory preset at 100 psi
- Pressure range 50 to 175 psi, calibrated in 25 psi increments
- Cast bronze body, SS springs
- Silicone soft seat, EPDM cap seal
- Maximum service temp: 200°F

Series Number	Size (in.)	Dimensions (in.)			Wt./100 (lbs.)
		A	B	C	
16-503-01	1/2 M x 1/2 F	1.31	3.44	1.00	37
16-504-01	3/4 M x 1/2 F	1.31	3.44	1.00	37

SAFETY & RELIEF VALVES

Hot Water Relief Valves

RVW 17 (17-400) SERIES

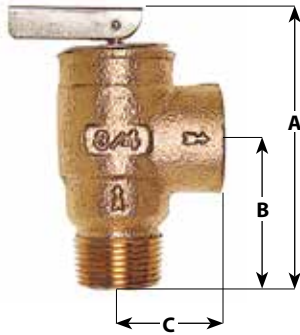

17-400



PRESSURE RELIEF VALVES

Prevents excessive thermal expansion buildup in plumbing systems, tank applications and tankless water heaters. Conforms to HUD/FHA requirements: ideal for well systems.

FEATURES

- Bronze body, stainless steel spring
- CSA certified design to ANSI Z21.22 "Relief Valves for Hot Water Supply Systems"
- ASME capacity certified from 75 to 150 psig*
- CRN #0G8547.5C Registered in all Canadian Provinces and Territories

Series Number	Size (in.)		CSA Capacity Rating BTU/Hr.	Wt./100 (lbs.)	*ASME Certified Discharge Capacities			
	Inlet NPT	Outlet NPT			75 BTU/Hr.	100 BTU/Hr.	125 BTU/Hr.	150 BTU/Hr.
17-401	1/2 M	1/2 F	15,000	57	-	-	-	-
17-402	3/4 M	3/4 F	200,000	53	505,000	648,000	791,000	934,000

Note: When ordering specify pressure by adding the two digit key number after the product number as follows: 75 psig - 01; 100 psig - 02; 125 psig - 03; 150 psig - 04; 160 psig - 05

* 3/4 model only: National Board Capacity Certified - BTU per hour (90% of actual capacity at 10% accumulation) ASME boiler and pressure vessel code - Section IV - Heating Boilers

COMMERCIAL PRODUCTS CATALOG

Temperature & Pressure Relief Valves

TP (18C-400) SERIES

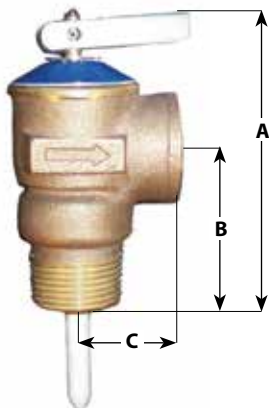

18C-400



WATER HEATER T&P RELIEF VALVES

Feature unique non-metallic coating which protects the element against galvanic and electromechanical corrosion by isolating it from the heated water. This coating is electrostatically applied for uniform coverage, then thermobonded, resulting in optimum adhesion for extended service life. CSA design certified at all settings to ANSI Z21.22. ASME Section IV rated at 125 psig and 150 psig settings for 3/4" NPT only.

FEATURES

- Meets HUD/FHA requirements
- Cast bronze body, SS spring
- Rated 210°F maximum
- CRN #OG0053.6C Registered in all Canadian Provinces and Territories
- ASME capacity certified for 3/4" NPT only

Series Number	Size (in.)	Element Length (in.)	CSA Capacity Rating BTU/Hr.	Wt./100 (lbs.)
18C-401	1/2 M x 1/2 F	1.44	15,000	48.0
18C-401	1/2 M x 1/2 F	3.00	15,000	54.0
18C-402	3/4 M x 3/4 F	1.44	95,000	52.0
18C-402	3/4 M x 3/4 F	3.00	105,000	58.0
18C-402	3/4 M x 3/4 F	8.00	105,000	62.0

Special statement regarding T&P Valves and compliance to the Lead Free requirements of the U.S. Safe Drinking Water Act.

Effective January 4th 2014 the SDWA requires that pipes, fittings or fixtures used to convey or dispense potable water must be lead free. Further clarification has been provided by the EPA in a document titled "Summary of the Reduction of Lead In Drinking Water Act and frequently Asked Questions". The latest document can be viewed on our website: www.apollovalves.com/lead_free; click on the NEW EPA FAQ link.

FAQ #6 states that water heaters are covered by the Act and must comply. However most water heater OEM's are certifying their heaters as complete assemblies using non-Lead Free T&P valves due to their relatively small wetted surface area.

FAQ #23 acknowledges this and states that replacement parts (including T&P valves) need not be lead free as long as the entire water heater with all installed components overall device would meet the Lead Free requirements of the Act.

SUFFIX KEY

Pressure psig	Coated Element Length				
	401 Series		402 Series		
	1.44"	3"	1.44"	3"	8"
125	-27	-29	-27	-29	-36
150	-28	-30	-28	-30	-37
175	-	-	-	-24	-

Temperature & Pressure Relief Valves

TPX (18C-402X) SERIES

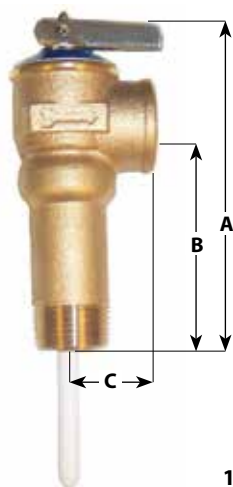

18C-402X
EXTENDED SHANK



EXTENDED SHANK WATER HEATER T&P RELIEF VALVES

Relief valves with an extended body length (2") for protection of water heaters with extra insulation. Unique non-metallic coating protects thermal element against galvanic and electromechanical corrosion. CSA design certified at all settings to ANSI Z21.22. ASME Section IV rated at 125 psig and 150 psig settings.

FEATURES

- Meets HUD/FHA requirements
- Cast bronze body, SS spring
- Rated 210°F maximum
- CRN #OG0053.6C Registered in all Canadian Provinces and Territories
- ASME capacity certified

Series Number	Size (in.)	Element Length (in.)	Pressure psig	CSA Capacity Rating BTU/Hr.	Wt./100 (lbs.)
18C-402X-39	3/4 M x 3/4 F	3	64.0	105,000	125
18C-402X-38	3/4 M x 3/4 F	3	64.0	105,000	150

SAFETY & RELIEF VALVES

Temperature & Pressure Relief Valves

TPC (18C-500) SERIES

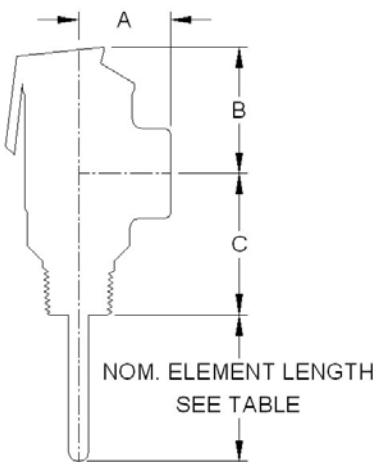

HIGH CAPACITY COMMERCIAL T&P VALVES

The Apollo 18C-500 Series bronze automatic temperature and pressure relief valves are used for protection of high capacity commercial hot water heaters and storage tanks.

FEATURES

- 3/4" through 2" NPT connections
- ASME Section IV certified capacity
- CSA listed and Certified to ANSI Z21.22
- 125 and 150 psig set pressures at 210°F max
- Coated element protects against corrosion
- SS elements (1-1/2" and 2")
- Canadian Registration Number CRN-0G1438.6C

Series Number	Size (in.)	Element Length (in.)	Inlet Type	CSA Capacity Rating Btu/HR	*ASME Cap. Rating BTU/HR
18C5113125	3/4"	2.69"	M	185,000	1,619,000
18C5113150	3/4"	2.69"	M	185,000	1,912,000
18C5115125	3/4"	4.38"	M	205,000	1,619,000
18C5115150	3/4"	4.38"	M	205,000	1,912,000
18C5118125	3/4"	7.56"	M	205,000	1,619,000
18C5118150	3/4"	7.56"	M	205,000	1,912,000
18C5123125	3/4"	2.88"	F	185,000	1,619,000
18C5123150	3/4"	2.88"	F	185,000	1,912,000
18C5125125	3/4"	4.56"	F	205,000	1,619,000
18C5125150	3/4"	4.56"	F	205,000	1,912,000
18C5128125	3/4"	7.75"	F	205,000	1,619,000
18C5128150	3/4"	7.75"	F	205,000	1,912,000
18C5213125	1"	3.06"	M	500,000	1,825,000
18C5213150	1"	3.06"	M	500,000	2,155,000
18C5215125	1"	4.75"	M	500,000	1,825,000
18C5215150	1"	4.75"	M	500,000	2,155,000
18C5225125	1"	4.75"	F	750,000	3,070,000
18C5225150	1"	4.75"	F	750,000	3,625,000
18C5228125	1"	8.13"	F	750,000	3,070,000
18C5228150	1"	8.13"	F	750,000	3,625,000
18C5314125	1-1/4" x 1"	3.97"	M	750,000	3,070,000
18C5314150	1-1/4" x 1"	3.97"	M	750,000	3,625,000
18C5424125	1-1/2"	4.13"	F	1,200,000	5,125,000
18C5424150	1-1/2"	4.13"	F	1,200,000	6,050,000
18C5513125	2" x 1-1/2"	3.25"	M	1,200,000	5,125,000
18C5513150	2" x 1-1/2"	3.25"	M	1,200,000	6,050,000

Series Number	Inlet Size (in./mm.)	Dimensions (in./mm.)		
		A	B	C
18C511	3/4" M x 3/4" FNPT	1.50	3.47	2.53
	(20)	(40)	(88)	(64)
18C512	3/4" F x 3/4" FNPT	1.50	3.47	2.35
	(20)	(40)	(88)	(60)
18C521	1" M x 1" FNPT	1.56	3.47	2.38
	(25)	(40)	(88)	(60)
18C522	1" F x 1" FNPT	1.56	3.47	2.13
	(25)	(40)	(88)	(54)
18C531	1-1/4" M x 1" FNPT	1.75	4.34	1.91
	(32)	(44)	(110)	(49)
18C542	1-1/2" M x 1-1/2" FNPT	2.47	5.84	1.71
	(40)	(63)	(148)	(43)
18C551	2" M x 1-1/2" FNPT	2.47	5.84	2.59
	(50)	(63)	(148)	(66)

* National Board certified capacity per ASME Section IV-Heating Boilers

Special statement regarding T&P Valves and compliance to the Lead Free requirements of the U.S. Safe Drinking Water Act.

Effective January 4th 2014 the SDWA requires that pipes, fittings or fixtures used to convey or dispense potable water must be lead free. Further clarification has been provided by the EPA in a document titled "Summary of the Reduction of Lead In Drinking Water Act and frequently Asked Questions". The latest document can be viewed on our website: www.apollovalves.com/lead_free; click on the NEW EPA FAQ link.

FAQ #6 states that water heaters are covered by the Act and must comply. However most water heater OEM's are certifying their heaters as complete assemblies using non-Lead Free T&P valves due to their relatively small wetted surface area.

FAQ #23 acknowledges this and states that replacement parts (including T&P valves) need not be lead free as long as the entire water heater with all installed components overall device would meet the Lead Free requirements of the Act.



See Safety & Relief Valve Catalog (SRCA9000) for more detailed information about the products in this section.

Customer Service (704) 841-6000

COMMERCIAL PRODUCTS CATALOG

ASME Section I & VIII Safety Valves

19 SERIES

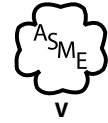
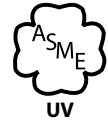
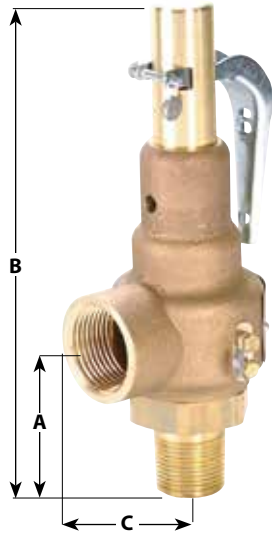

BRONZE SAFETY VALVES FOR STEAM, AIR & GAS SERVICE

National Board capacity certified, high capacity, ideal for use with steam boilers, sterilizers, pressure vessels, compressors, and pressure piping systems.

FEATURES

- Pressures: 15 through 300 psig steam, air, gas
- Max. temp. 406°F with stainless steel trim
- 13 Sizes, 1/2" through 2-1/2" NPT
- Stainless steel springs
- Optional 316 stainless steel wetted trim (Specify 19L or 19S Series)
- Available in metal and soft seat designs
- Metal to metal seat lapped to optical flatness (19M)
- PFA Teflon® soft seat easily replaced (19K)
- Double ring, full bore, high capacity design
- Tapped body drain facilitates piping of condensate away from equipment
- Registered in all Canadian Provinces and Territories, CRN #0G8547.5C
- Wide wrenching hex for easier, faster installations
- Dual ASME/CE European Pressure Equipment Directive Compliant option

Series Number	Orifice Designation	Inlet Size (in.)	Dimensions (in.)			Wt./100 (lbs.)
			A	B	C	
19KDC	D	1/2 x 3/4	2.21	6.52	1.37	1.6
19KDD	D	3/4 x 3/4	2.21	6.52	1.37	1.6
19KED	E	3/4 x 1	2.50	7.16	1.75	2.0
19KEE	E	1 x 1	2.64	7.30	1.75	2.2
19KFE	F	1 x 1-1/4	2.95	9.34	2.00	4.1
19KFF	F	1-1/4 x 1-1/4	2.95	9.34	2.00	4.3
19KGF	G	1-1/4 x 1-1/2	3.38	11.01	2.37	7.4
19KGG	G	1-1/2 x 1-1/2	3.38	11.01	2.37	7.6
19KHG	H	1-1/2 x 2	3.63	11.96	2.75	11.5
19KHH	H	2 x 2	3.63	11.96	2.75	11.6
19KJG	J	1-1/2 F X 2-1/2	3.80	14.00	3.50	20.0
19KJH	J	2 x 2-1/2	4.06	14.25	3.50	19.9
19KJJ	J	2-1/2 x 2-1/2	4.50	14.68	3.50	20.8

CERTIFIED CAPACITIES

Set Pressure psig	Orifice					
	D	E	F	G	H	J
15	174	310	484	794	1,240	2,035
25	229	408	637	1,045	1,631	2,677
40	311	555	866	1,421	2,217	3,641
50	366	653	1,019	1,672	2,608	4,283
100	646	1,152	1,798	2,950	4,602	7,557
125	787	1,404	2,191	3,595	5,609	9,210
150	929	1,656	2,585	4,240	6,616	10,864
165	1,014	1,807	2,821	4,628	7,220	11,856
200	1,211	2,160	3,371	5,531	8,630	14,170
250	1,494	2,664	4,158	6,822	10,644	17,477
300*	1,777	3,168	4,945	8,112	12,658	20,784
Approx 1 psi increments	5.7	10.1	15.7	25.8	40.3	66.1

ASME Section I Steam

Power Boiler - "V" steam lbs./hr. steam @ 3% accumulation

*Specify Model 19S with stainless steel wetted trim for steam settings beyond 250 psig.

SAFETY & RELIEF VALVES

ASME Section I & VIII Safety Valves

19 SERIES (CONT.)

BRONZE SAFETY VALVES FOR STEAM, AIR & GAS SERVICE

ASME Section VIII Steam

Unfired Pressure Vessels - "UV" steam lbs./hr.
@ 10% accumulation

**Specify Model 19S with stainless steel wetted trim
for steam settings beyond 250 psig.*

CERTIFIED CAPACITIES

Set Pressure psig	Orifice					
	D	E	F	G	H	J
15	179	320	499	819	1,278	2,099
25	234	417	652	1,070	1,669	2,741
40	322	574	896	1,471	2,295	3,768
50	382	682	1,064	1,746	2,725	4,474
100	684	1,220	1,904	3,124	4,875	8,005
125	835	1,489	2,324	3,813	5,950	9,770
150	985	1,758	2,744	4,502	7,025	11,535
165	1,076	1,920	2,996	4,916	7,670	12,594
200	1,287	2,296	3,584	5,881	9,175	15,066
250	1,590	2,834	4,424	7,259	11,325	18,596
300*	1,892	3,373	5,265	8,639	13,479	22,132
Approx 1 psi increments	6.0	10.8	16.8	27.6	43.0	70.6

ASME Section VIII Air

Unfired Pressure Vessels - "UV" air SCFM @
10% accumulation

CERTIFIED CAPACITIES

Set Pressure psig	Orifice					
	D	E	F	G	H	J
15	64	114	178	292	455	747
25	83	149	232	381	594	976
40	115	204	319	524	817	1,342
50	136	243	379	622	970	1,593
100	244	434	678	1,112	1,736	2,849
125	297	530	828	1,358	2,118	3,478
150	351	626	977	1,603	2,501	4,106
165	383	683	1,067	1,750	2,731	4,484
200	459	818	1,276	2,094	3,267	5,364
250	566	1,009	1,575	2,584	4,032	6,621
300	673	1,201	1,874	3,075	4,798	7,878
Approx 1 psi increments	2.2	3.8	6.0	9.8	15.3	25.1

19 SERIES NUMBERING SYSTEM

19M	D	C	K	165	A
BASE MODEL NUMBER	ORIFICE LETTER	INLET SIZE (IN.) NPT	ASME CODE AND SERVICE	SET PRESSURE IN PSI	SPECIAL OPTIONS
19K = Brass Trim/Teflon Seat	D	C = 1/2	A = Sect. I Steam		A = Anti-vibration trim
19M = Brass Trim/Metal Seat	E	D = 3/4	K = Sect. VIII Air		CE = CE/PED Compliant
19L = Stainless Trim/Teflon Seat	F	E = 1	L = Sect. VIII Steam		Q = Performance (Calibration) test report
19S = Stainless Trim/Metal Seat	G	F = 1-1/4	N = Non-Code Air		X = Oxygen cleaning
	H	G = 1-1/2	P = Non-Code Steam		* Other suffixes - factory issued
	J	H = 2			
		J = 2-1/2			



See Safety & Relief Valve Catalog (SRCA9000) for more detailed information about the products in this section.

Customer Service (704) 841-6000

COMMERCIAL PRODUCTS CATALOG

ASME Section I & VIII Safety Valves

29 SERIES

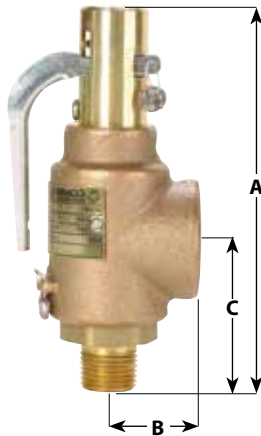

OEM STYLE BRONZE SAFETY VALVES FOR STEAM, AIR & NON-HAZARDOUS GAS

Ideally suited for OEM applications where compact size, dependable performance and maximum economy are required. These rugged safety valves feature a top guided design and patented Teflon® "soft-seat" for dramatically reduced seat leakage. Flow ratings are National Board certified.

FEATURES

- Stainless steel springs are standard
- PFA Teflon® seat resists corrosive boiler chemicals
- Pressure settings from 30 to 200 psig
- Rust proofed steel stem and spring washers
- Lower control ring ensures short, consistent blowdown
- Tapped body drain allows piping of condensate away from equipment
- Reduced repair costs; soft seat easily replaced
- Registered in All Canadian Provinces under CSA B51 CRN #0G8547.5C
- Optional European Pressure Equipment Directive Compliance

Series Number	Size (in.)		Dimensions (in.)			Wt./100 (lbs.)
	Inlet	Outlet	A	B	C	
29-102	3/8	1	5.41	1.25	2.12	1.30
29-202	1/2	1	5.41	1.25	2.12	1.33
29-302	3/4	1	5.41	1.25	2.12	1.90
29-303	3/4	1-1/4	7.25	1.69	2.75	3.43
29-402	1	1-1/4	7.25	1.69	2.75	3.43
29-501	1-1/4	1-1/4	7.25	1.69	2.75	3.48

ASME Section I Steam

Power Boiler "V" steam lbs./hr. @ 3% accumulation

Set Pressure psig	29-102	29-303
	29-202 29-302	29-402 29-501
50	238	479
75	331	664
100	423	851
125	516	1,036
150	608	1,223
200	794	1,596
Approx 1 psi increments	3.7	7.4

ASME Section VIII Steam

Unfired pressure vessels - "UV" steam lbs./hr. @ 10% accumulation

Set Pressure psig	29-102	29-303
	29-202 29-302	29-402 29-501
50	251	504
75	350	704
100	448	902
125	547	1,102
150	646	1,299
200	844	1,697
Approx 1 psi increments	3.9	8.0

ASME Section VIII Air

Unfired pressure vessels - "UV" air SCFM @ 10% accumulation

Set Pressure psig	29-102	29-303
	29-202 29-302	29-402 29-501
50	89	180
75	124	250
100	159	321
125	194	391
150	230	463
200	300	604
Approx 1 psi increments	1.4	2.8

29 SERIES NUMBERING SYSTEM

29	202	A	100	S
BASE MODEL NUMBER	INLET x OUTLET NPT	SERVICE	SET PRESSURE	OPTIONS
Bronze with Brass Trim and Teflon® Soft Seat	102 = 3/8 x 1 202 = 1/2 x 1 302 = 3/4 x 1 303 = 3/4 x 1-1/4 402 = 1 x 1-1/4 501 = 1-1/4 x 1-1/4	A = ASME Sec I Steam K = ASME Sec VIII Air L = ASME Sec VIII Steam	Set Pressure, PSIG (range 30-200 psig)	S = Stainless Steel Wetted Trim (models 29-202 & 29-303 only) CE = CE/PED Q = Performance (Calibration) test reports

SAFETY & RELIEF VALVES

ASME Section I & VIII Safety Valves

119 SERIES



CAST IRON SAFETY VALVE

High capacity safety valves ideal for use with all types of boilers, pressure vessels and pressure piping systems. Their top-guided design includes two control rings that ensure seat tightness. Direct replacement for most competitive models.

FEATURES

- Set pressures to 250 psig @ 450°F max
- Flanged inlet sizes: 1-1/2" through 6" ANSI 250 lb; some sizes available in female NPT
- National Board Certified ASME flow ratings
- 316 stainless steel wetted trim (disc and nozzle) is standard
- Metal to metal seating, lapped to optical flatness
- Semi-nozzle design available in eight orifice sizes
- Rust proof steel stem, spring and spring washers
- Drip pan elbows are available (see page 90)
- Registered in all Canadian Provinces Under CSA B51, CRN #0G8547.5C
- Optional dual ASME/European Pressure Equipment Directive Compliance

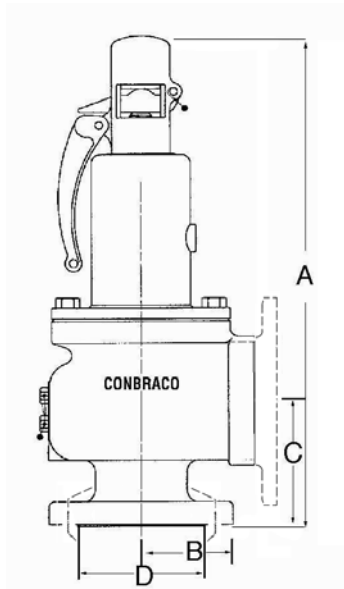

Series Number	Valve Size (in.)	Orifice Letter	Orifice Area (sq. in.)	Dimensions (in.)				Wt./ (lbs.) APP
				A	B	C	Hex D	
119 JGC	1-1/2 250# x 2 1/2 FNPT	J	1.36	15.00	4.00	4.31		35
119 KHC	2 250# x 3 FNPT	K	1.93	16.00	4.00	4.62		36
119 KHA	2 FNPT x 3 FNPT	K	1.93	16.00	4.00	4.62	3-3/4	37
119 KJC	2-1/2 250# x 3 FNPT	K	1.93	16.00	4.00	4.62		41
119 KKC	3 250# X 3 FNPT	K	1.93	16.00	4.00	4.63		45
119 LJC	2-1/2 250# x 4 FNPT	L	2.99	22.00	5.12	5.62		84
119 LJA	2-1/2 FNPT x 4 FNPT	L	2.99	22.00	5.12	5.62	5-3/8	81
119 LKC	3 250# x 4 FNPT	L	2.99	22.00	5.12	5.62		85
119 LMC	4 250# X 4 FNPT	L	2.99	22.00	5.13	5.63		90
119 MKA	3 FNPT x 4 FNPT	M	3.77	22.00	5.12	5.62	5-3/8	80
119 MKC	3 250# x 4 FNPT	M	3.77	22.00	5.12	5.62		87
119 MMC	4 250# X 4 FNPT	M	3.77	22.00	5.13	5.63		95
119 NMD	4 250# x 6 125#	N	4.55	28.00	7.25	6.75		210
119 PMD	4 250# x 6 125#	P	6.69	28.00	7.25	6.75		215
119 QPD	6 250# x 8 125#	Q	11.59	42.00	10.00	9.25		530
119 RPD	6 250# x 8 125#	R	16.79	42.00	10.00	9.25		530

Information required for ordering 119 series valves:

1. Determine the orifice letter that corresponds to your required flow rate from the following capacity charts.
2. Select the inlet x outlet connection options from the list of models available for that orifice (above).
3. Specify base model number, set pressure, ASME Code section and service.

For Further information request catalog SRCA9000

119 SERIES NUMBERING SYSTEM

119	K	H	C	A	MAA	0150	Q
SERIES NUMBER	ORIFICE LETTER	INLET (IN.)	CONNECTION	SERVICE	SPECIAL OPTIONS	SET PRESSURE	SUFFIX
119 = Stainless Steel Wetted Trim	The orifice letter from the Capacity Chart (pg. 84)	G = 1-1/2 H = 2 J = 2-1/2 K = 3 M = 4 P = 6	A = FNPT x FNPT C = 250# x FNPT D = 250# x 125#	A = Sec I Steam K = Sec VIII Air L = Sec VIII Steam N = Non Code Air P = Non Code Steam	Factory issued letters/numbers (MAA default) MCE = CE/PED	Set Pressure, PSIG (4 digits)	Q = Performance (Calibration) test reports



See Safety & Relief Valve Catalog (SRCA9000) for more detailed information about the products in this section.

Customer Service (704) 841-6000

COMMERCIAL PRODUCTS CATALOG

ASME Section I & VIII Safety Valves

119 SERIES (CONT.)

ASME SECTION I

Steam Boilers - Pounds of saturated steam per hour @ 3% or 2 psig accumulation, whichever is greater.

ASME SECTION VIII

Pressure Vessels - Pounds of saturated steam per hour @ 10% or 3 psig accumulation, whichever is greater.

ASME SECTION VIII

Pressure Vessels - Standard cubic feet of air per minute @ 10% or 3 psig, whichever is greater.

Note: Available factory preset at any pressure 15-250 psig.

J ORIFICE

Set Pressure psig	ASME Section I Steam lbs./hr.	ASME Section VIII Steam lbs./hr.	ASME Section VIII Air SCFM
15	1947	2008	715
30	2868	2929	1043
50	4096	4280	1523
75	5646	5969	2124
100	7227	7657	2726
125	8809	9346	3327
150	10390	11034	3928
175	11971	12723	4529
200	13552	14412	5130
225	15133	16100	5731
250	16714	17789	6332

K ORIFICE

Set Pressure psig	ASME Section I Steam lbs./hr.	ASME Section VIII Steam lbs./hr.	ASME Section VIII Air SCFM
15	2761	2848	1014
30	4067	4154	1479
50	5809	6070	2161
75	8008	8465	3013
100	10250	10860	3865
125	12493	13255	4718
150	14735	15650	5570
175	16978	18045	6423
200	19220	20440	7275
225	21463	22834	8128
250	23705	25229	8980

L ORIFICE

Set Pressure psig	ASME Section I Steam lbs./hr.	ASME Section VIII Steam lbs./hr.	ASME Section VIII Air SCFM
15	4286	4421	1574
30	6314	6449	2295
50	9018	9423	3354
75	12432	13141	4678
100	15913	16859	6001
125	19394	20577	7324
150	22876	24295	8648
175	26357	28013	9971
200	29838	31731	11294
225	33320	35449	12618
250	36801	39167	13941

M ORIFICE

Set Pressure psig	ASME Section I Steam lbs./hr.	ASME Section VIII Steam lbs./hr.	ASME Section VIII Air SCFM
15	5410	5580	1986
30	7969	8140	2897
50	11382	11894	4234
75	15691	16587	5904
100	20085	21280	7574
125	24480	25973	9245
150	28874	30666	10915
175	33268	35358	12586
200	37662	40051	14256
225	42056	44744	15926
250	46451	49437	17597

N ORIFICE

Set Pressure psig	ASME Section I Steam lbs./hr.	ASME Section VIII Steam lbs./hr.	ASME Section VIII Air SCFM
15	6522	6728	2395
30	9608	9814	3493
50	13723	14340	5104
75	18918	19998	7118
100	24215	25655	9132
125	29513	31313	11146
150	34811	36971	13160
175	40108	42629	15173
200	45406	48287	17187
225	50704	53944	19201
250	56002	59602	21215

P ORIFICE

Set Pressure psig	ASME Section I Steam lbs./hr.	ASME Section VIII Steam lbs./hr.	ASME Section VIII Air SCFM
15	9592	9895	3522
30	14131	14434	5138
50	20183	21091	7507
75	27823	29412	10469
100	35615	37733	13431
125	43407	46055	16393
150	51199	54376	19355
175	58990	62697	22317
200	66782	71018	25278
225	74574	79340	28240
250	82366	87661	31202

Q ORIFICE

Set Pressure psig	ASME Section I Steam lbs./hr.	ASME Section VIII Steam lbs./hr.	ASME Section VIII Air SCFM
15	16617	17141	6101
30	24480	25004	8900
50	34964	36537	13005
75	48200	50952	18136
100	61698	65368	23267
125	75197	79783	28398
150	88695	94199	33529
175	102193	108614	38660
200	115691	123030	43791
225	129189	137445	48923
250	142687	151861	54054

R ORIFICE

Set Pressure psig	ASME Section I Steam lbs./hr.	ASME Section VIII Steam lbs./hr.	ASME Section VIII Air SCFM
15	24061	24820	8834
30	35446	36205	12887
50	50628	52903	18830
75	69791	73776	26260
100	89336	94649	33689
125	108880	115522	41119
150	128425	136395	48549
175	147969	157267	55978
200	167514	178140	63408
225	187059	199013	70837
250	206603	219886	78267

SAFETY & RELIEF VALVES

Safety Relief Valves

500 SERIES



ASME SECTION VIII SAFETY RELIEF VALVES

Versatile ASME Section VIII safety relief valve certified for steam, air/gas and liquid service. Choice of bronze, carbon steel or stainless steel bodies to suit a wide range of applications.

FEATURES

- Set pressures to 1200 psig @ 800°F max
- Inlet sizes 1/2" through 2"
- Wide range of materials and options
- High capacity full nozzle design
- Stainless steel springs are standard
- Short "tuned" blowdown
- API 527 seat tightness
- Back pressure tight bonnet design
- Packed lever and screwed cap designs
- One trim suitable for all types of service
- Optional soft seating
- CSA B51 CRN #0G8547.5C
- Optional Dual ASME/CE European Pressure Equipment Directive Compliance Marking

Series Number	Valve Size (in.)	Orifice Letter	Flow Area (sq. in.)	Dimensions (in.)			Wt. Ea. (lbs.)
				A	B	C	
5xxDC	1/2 X 1	D	0.13	2.37	7.50	1.62	2.0
5xxDCD*	1/2 X 3/4	D	0.13	2.37	7.50	1.62	2.0
5xxDD	3/4 X 1	D	0.13	2.37	7.50	1.62	2.0
5xxDDD*	3/4 X 3/4	D	0.13	2.37	7.50	1.62	2.0
5xxED	3/4 X 1-1/4	E	0.23	2.62	9.00	2.00	3.0
5xxEE	1 X 1-1/4	E	0.23	2.62	9.00	2.00	3.0
5xxFE	1 X 1-1/2	F	0.36	2.87	10.25	2.37	5.0
5xxFF	1-1/4 X 1-1/2	F	0.36	2.87	10.25	2.37	5.0
5xxGF	1-1/4 X 2	G	0.59	3.25	13.25	2.62	9.0
5xxGG	1-1/2 X 2	G	0.59	3.25	13.25	2.62	9.5
5xxHG	1-1/2 X 2-1/2	H	0.92	3.50	15.00	2.75	15.5
5xxHH	2 X 2-1/2	H	0.92	3.50	15.00	2.75	16.0
5xxJH	2 X 3	J	1.50	4.00	17.00	3.25	23.0

* 3/4" outlet option available with 510 and 520 bronze bodied models only.

500 SERIES NUMBERING SYSTEM

52	3	J	H	B	K	M	AA	0425	Q
SERIES BODY/TRIM MATERIAL	CAP	ORIFICE LETTER	INLET SIZE	CONNECTION	SERVICE	SEAT	SPECIAL OPTIONS	SET PRESSURE	SUFFIX
51 = Bronze/Brass	1 = Screwed Cap	D	C = 1/2	B = MNPT x NPT	J = Sec VIII Liquid	M = Metal	Factory Issued Letters/Numbers for Special Options or Features "AA" = Default Setting "CE" = CE/PED "HT" = High Temp Spring "OX" = Cleaned for Oxygen	Set Pressure, PSIG (4 digits) Vacuum "HG" Prefix + 2 digits	Q = Performance (Calibration) Test Reports
52 = Bronze/Stainless	2 = Screwed + Gag	E	D = 3/4	D = 3/4 Outlet (Model 510 & 520 D Orifice Only)	K = Sec VIII Air/Gas	B = BUNA-N			
53 = Carbon/Stainless	3 = Packed Lever	F	E = 1		L = Sec VIII Steam	E = EPR			
54 = All Stainless	4 = Packed + Gag	G	F = 1-1/4		M = Non Code Liquid	K = PCTFE			
		H	G = 1-1/2		N = Non Code Air	N = Neoprene			
		J	H = 2		P = Non Code Steam	Z = Kalrez®			
					Q = Vacuum	S = Silicone			
						V = Viton			

Notes:

1. The ASME Code Section VIII requires a lift lever for the following services: air, steam, or hot water over 140°F
2. Maximum back pressure is 50 psig.
3. High temperature stainless steel alloy spring is required above 550°F / 288°C. Specify option "HT"
4. Contact factory for pricing and availability.



See Safety & Relief Valve Catalog (SRCA9000) for more detailed information about the products in this section.

Customer Service (704) 841-6000

COMMERCIAL PRODUCTS CATALOG

Safety Relief Valves

500 SERIES (CONT.)

ASME SECTION VIII SAFETY RELIEF VALVES

Pressure and Temperature Ratings

Series Body Trim	510 Bronze Brass	520 Bronze Stainless	530 Carbon Steel Stainless	540 Stainless Steel Stainless
Max. Set-Steam	250 PSI	300 PSI	900 PSI (D/E) 600 PSI (F/G) 500 PSI (H/J)	900 PSI (D/E) 600 PSI (F/G) 500 PSI (H/J)
Max. Set-Air/ Gas/Liquid	300 PSI	1200 PSI (D) ¹ 900 PSI (E) 600 PSI (F/G) 500 PSI (H/J)	1200 PSI (D) ¹ 900 PSI (E) 600 PSI (F/G) 500 PSI (H/J)	1200 PSI (D) ¹ 900 PSI (E) 600 PSI (F/G) 500 PSI (H/J)
Temp. Limits*	-320/406°F	-320/422°F	-20/800°F	-320/800°F

¹Max set pressure for liquids is 1000 psi.

Notes:

- Limits based upon materials of construction and use of metal to metal seating. Refer to 500 series soft seat chart for limitations based upon elastomer.
- Specify "HT" high temperature Inconel springs for service temperature beyond 550°F.
- * Models 510, 520 and 540 are suitable for cryogenic service to -320°F, with choice of either "M" metal or "K" PCTFE seat options.

ASME Section VIII Water - US gallons per minute @ 10% overpressure. NATIONAL BOARD CERTIFIED.

Set Pressure psig	Orifice					
	D	E	F	G	H	J
15	14	25	40	65	102	167
20	16	29	45	74	115	189
25	18	32	50	82	127	208
30	19	34	54	89	138	226
35	21	37	58	96	149	244
40	22	40	62	102	160	261
45	24	42	66	108	169	277
50	25	44	70	114	178	292
55	26	46	73	120	187	306
60	28	48	76	125	195	320
65	29	50	79	130	203	333
70	30	52	82	135	211	345
75	31	54	85	140	218	357
80	32	56	88	145	226	369
85	33	58	91	149	233	381
90	34	59	93	153	239	392
95	35	61	96	158	246	402
100	36	63	98	162	252	413
125	40	70	110	181	282	462
150	44	77	121	198	309	506
175	47	83	130	214	334	546
200	50	89	139	229	357	584
225	53	94	148	242	378	619
250	56	99	156	256	399	653
275	59	104	163	268	418	685
300	62	108	171	280	437	715
325	64	113	178	291	455	744
350	66	117	184	302	472	772
375	69	121	191	313	489	799
400	71	125	197	323	505	826
425	73	129	203	333	520	851
450	75	133	209	343	535	876
475	77	136	215	352	550	900
500	79	140	220	361	564	923
525	81	143	226	370		
550	83	147	231	379		
575	85	150	236	388		
600	87	153	241	396		
625	89	157				
650	91	160				
675	92	163				
700	94	166				
725	96	169				
750	97	171				
775	99	174				
800	100	177				
825	102	180				
850	104	183				
875	105	185				
900	107	188				
950	109					
1000	112					

Note: To determine water capacity at 25% overpressure, multiply the capacity at 10% above by 1.066.

SAFETY & RELIEF VALVES

Safety Relief Valves

500 SERIES (CONT.)

ASME SECTION VIII SAFETY RELIEF VALVES

ASME Section VIII Steam - Pounds per hour of saturated steam @ 10% overpressure. NATIONAL BOARD CERTIFIED.

Set Pressure psig	Orifice					
	D	E	F	G	H	J
15	188	331	520	853	1332	2180
20	216	381	600	984	1536	2513
25	245	432	679	1114	1740	2846
30	274	482	759	1245	1943	3180
35	305	538	846	1388	2168	3546
40	337	593	934	1532	2392	3913
45	368	649	1021	1676	2616	4280
50	400	705	1108	1819	2840	4646
55	431	760	1196	1963	3064	5013
60	463	816	1283	2106	3288	5380
65	494	872	1371	2250	3512	5746
70	526	927	1458	2393	3736	6113
75	558	983	1546	2537	3960	6479
80	589	1038	1633	2680	4184	6846
85	621	1094	1721	2824	4408	7213
90	652	1150	1808	2968	4632	7579
95	684	1205	1896	3111	4857	7946
100	715	1261	1983	3255	5081	8313
125	873	1539	2421	3972	6201	10146
150	1031	1817	2858	4690	7322	11979
175	1189	2095	3295	5408	8442	13812
200	1346	2373	3733	6126	9562	15645
225	1504	2651	4170	6843	10683	17478
250	1662	2929	4607	7561	11803	19312
275	1820	3207	5045	8279	12924	21145
300	1977	3485	5482	8997	14044	22978
325	2135	3763	5919	9714	15165	24811
350	2293	4041	6357	10432	16285	26644
375	2451	4319	6794	11150	17405	28477
400	2608	4597	7231	11867	18526	30311
425	2766	4875	7669	12585	19646	32144
450	2924	5153	8106	13303	20767	33977
475	3082	5431	8543	14021	21887	35810
500	3239	5709	8981	14738	23008	37643
525	3397	5987	9418	15456		
550	3555	6266	9855	16174		
575	3713	6544	10293	16892		
600	3870	6822	10730	17609		
625	4028	7100				
650	4186	7378				
675	4344	7656				
700	4501	7934				
725	4659	8212				
750	4817	8490				
775	4975	8768				
800	5132	9046				
825	5290	9324				
850	5448	9602				
875	5606	9880				
900	5763	10158				
Approx. 1 psi Increment	6.3	11.1	17.5	28.7	44.8	73.3

ASME Section VIII Air - Standard cubic feet of air per minute @ 10% overpressure. NATIONAL BOARD CERTIFIED.

Set Pressure psig	Orifice					
	D	E	F	G	H	J
15	67	118	185	304	474	776
20	77	136	213	350	547	895
25	87	154	242	397	619	1013
30	97	172	270	443	692	1132
35	109	191	301	494	772	1262
40	120	211	332	545	851	1393
45	131	231	363	596	931	1523
50	142	251	395	648	1011	1654
55	154	271	426	699	1091	1784
60	165	290	457	750	1170	1915
65	176	310	488	801	1250	2045
70	187	330	519	852	1330	2176
75	198	350	550	903	1410	2306
80	210	370	581	954	1489	2437
85	221	389	612	1005	1569	2567
90	232	409	644	1056	1649	2698
95	243	429	675	1107	1729	2828
100	255	449	706	1158	1808	2959
125	311	548	862	1414	2207	3611
150	367	647	1017	1669	2606	4264
175	423	746	1173	1925	3005	4916
200	479	845	1329	2180	3404	5569
225	535	944	1484	2436	3802	6221
250	592	1043	1640	2691	4201	6874
275	648	1142	1796	2947	4600	7526
300	704	1240	1951	3202	4999	8179
325	760	1339	2107	3458	5398	8831
350	816	1438	2263	3713	5796	9484
375	872	1537	2418	3969	6195	10136
400	928	1636	2574	4224	6594	10789
425	985	1735	2730	4480	6993	11441
450	1041	1834	2885	4735	7392	12094
475	1097	1933	3041	4991	7791	12746
500	1153	2032	3197	5246	8189	13399
525	1209	2131	3352	5501		
550	1265	2230	3508	5757		
575	1321	2329	3664	6012		
600	1378	2428	3819	6268		
625	1434	2527				
650	1490	2626				
675	1546	2725				
700	1602	2824				
725	1658	2923				
750	1715	3022				
775	1771	3121				
800	1827	3220				
825	1883	3319				
850	1939	3418				
875	1995	3517				
900	2051	3616				
950	2163					
1000	2276					
1050	2388					
1100	2501					
1150	2613					
1200	2725					
Approx. 1 psi Increment	2.2	4	6.2	10.2	16	26.1



See Safety & Relief Valve Catalog (SRCA9000) for more detailed information about the products in this section.

Customer Service (704) 841-6000

COMMERCIAL PRODUCTS CATALOG

Accessories



DRIP PAN ELBOW – APOLLO INTERNATIONAL™

The use of a drip pan elbow is highly recommended for steam service safety valves. When attached to a safety valve outlet, these elbows collect and remove condensate as well as isolate the valve from discharge piping stresses. Elbows through 4" feature female NPT threads and connect to the valve outlet by means of a close nipple. The 6" and 8" elbows have integral 125# ANSI B16.1 flanges and bolt directly to the valve outlet.

Series Number	Size (In.) NPS/DN	Dimensions (in./mm.)							Wt./Ea. (lbs./kg.)
		A NPS/DN	B	C	D	E	F	G NPS/DN	
DPE 07	3/4	1-1/2	3.75	1.63	2.25	1	1.5	1/4	2
	20	40	95	41	57	25	40	8	.9
DPE 10	1	1-1/2	3.75	1.63	2.25	1	1.5	1/4	2
	25	40	95	41	57	25	40	8	.9
DPE 12	1-1/4	2	5.5	2.13	3.38	1.5	2.13	3/8	5
	32	50	127	54	86	40	54	10	2.1
DPE 15	1-1/2	2	5.5	2.13	3.38	1.5	2.13	3/8	5
	40	50	127	54	86	40	54	10	2.1
DPE 20	2	3	6.25	2.25	3.63	1.63	2.25	1/2	7
	50	80	159	57	92	41	57	15	3.2
DPE 25	2-1/2	4	7.38	3	4.38	1.88	2.75	3/4	11
	65	100	187	80	111	48	70	20	5.0
DPE 30	3	4	8	3.5	4.88	2.13	3.13	3/4	17
	80	100	200	89	124	54	80	20	7.7
DPE 40	4	6	9.63	4.5	5.75	2.63	3.75	3/4	30
	100	150	245	114	146	67	95	20	13.6
DPE 60	6	8	12.75	6.63	7.63	3	8	3/4	84
	150	200	324	168	194	80	200	20	38.1
DPE 80	8	10	16.5	7.5	8.63	4.13	10.75	1	151
	200	250	419	191	219	105	273	25	68.5

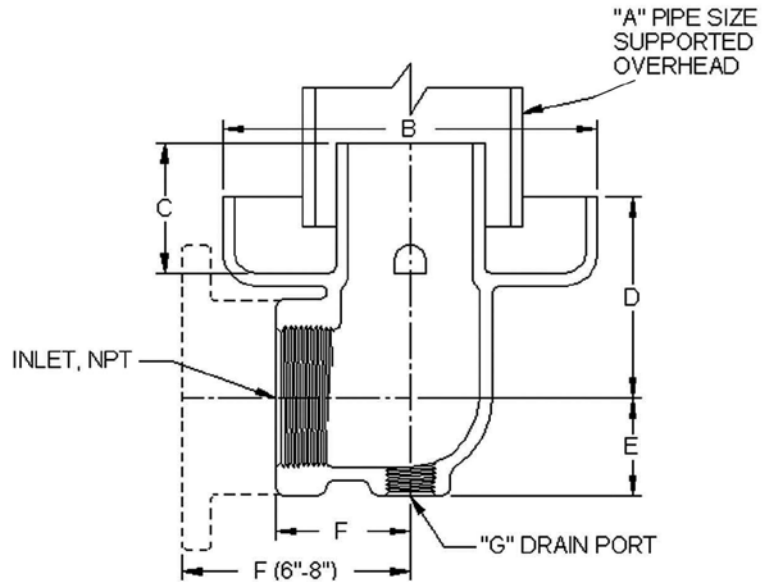

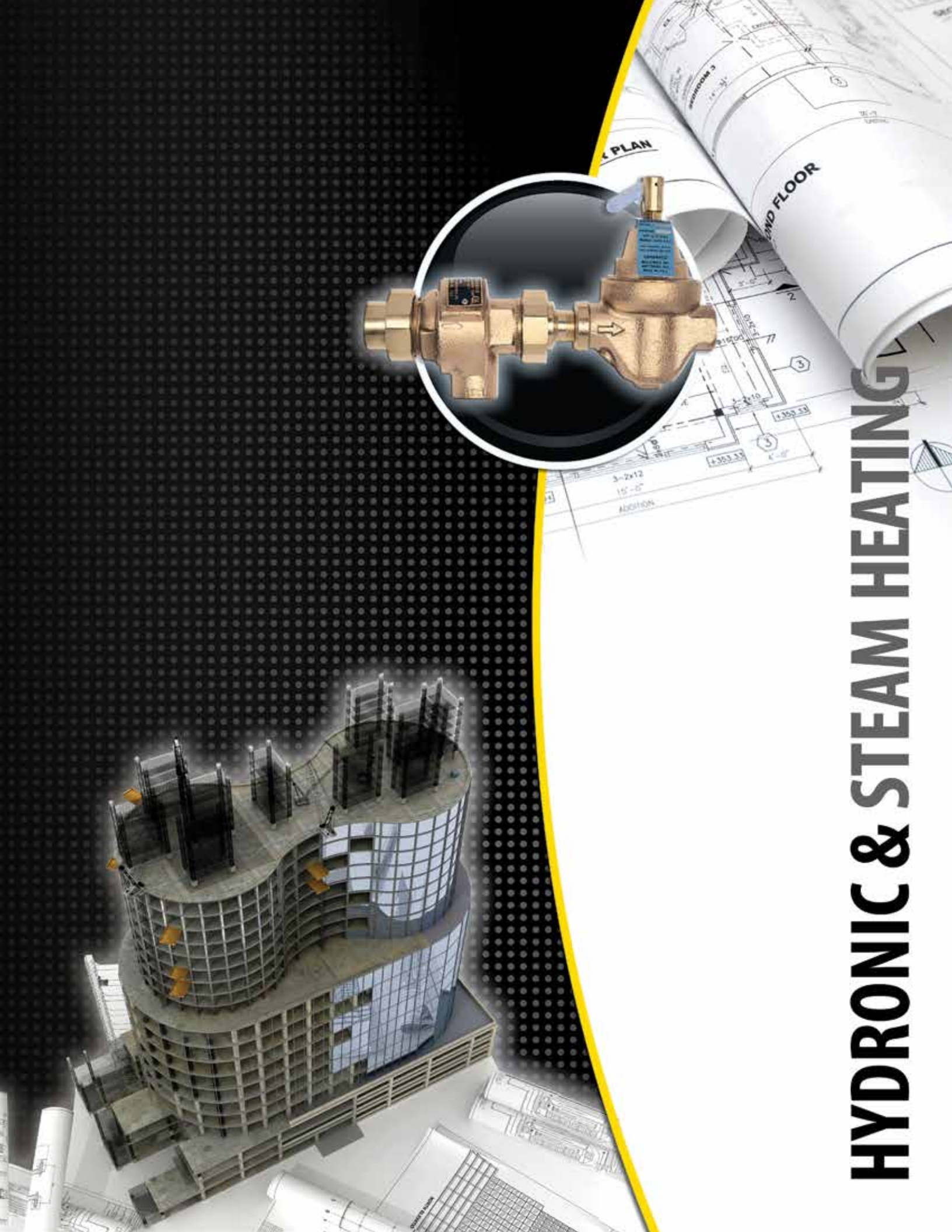

HYDRONIC & STEAM HEATING



PLAN

ND FLOOR

3-2x12
15'-0"
Abandon

Quantity Schedule

HYDRONIC & STEAM HEATING



See Hydronic & Steam Heating Catalog (PHBRHYD) for more detailed information about the products in this section.

HYDRONIC & STEAM HEATING

Hydronic Heating Specialties

EXT (16-XT) SERIES



EXPANSION TANKS FOR HYDRONIC SYSTEMS

Conbraco non-potable expansion tanks help maintain balanced pressure throughout a hot water heating system by absorbing thermal expansion. Pre-pressurized, they're designed to prevent system damage and unnecessary discharges by relief valves and ensure long, trouble-free system life.

FEATURES

- Welded steel construction
- Rugged flexible diaphragm
- Pre-charged at 12 psig
- Compact design saves energy and space
- Glycol compatible
- Maximum working pressure: 100 psig
- Maximum temperature: 240°F
- Chlorobutyl diaphragm
- Ideal for peak use systems such as car washes, processing plants, and hotels
- **Made in USA**

Series Number	Capacity (gal.)	Exp. Vol. (gal.)	Connection	Dimensions (in.)		Net Wt. (lbs.)
				Height	Diameter	
16-XT1-03	2	1.9	1/2 NPT	12.5	8.25	5
16-XT3-03	5	4.8	1/2 NPT	14.75	11	8
16-XT5-03	7	7.3	1/2 NPT	21.12	11	12
16-XT7-03	14	14.68	1 NPT	21.62	15.37	22

RAV (27-200) SERIES



RADIATOR AIR VALVE – APOLLO INTERNATIONAL™

Manual air purge valves for hot water radiators/heating systems.

Series Number	Size (in.)	Net Wt. (lbs.)
27-202-02	1/8	2.0
H-2404-00	Key only	0.9

FF (35) SERIES



BRONZE FEED WATER PRESSURE REGULATORS

Available in 1/2" union threaded, threaded and solder union configurations. Purge lever/fast fill feature. Cartridge is replaceable inline.

FEATURES

- No cage screws
- Factory pre-set to 15 psig - adjustable 10 to 25 psig
- Max temperature 210°F, Max supply pressure 100 psi
- High capacity
- Integral check and Stainless Steel strainer
- Rugged high temperature Nitrile elastomers

Series Number	Size (in.)	Height (in.)	Length (in.)	Net Wt. (lbs.)
35-503-01	1/2 Union Threaded	5.25	4.31	2.5
35-603-01	1/2 Threaded	5.25	3.50	2.2
35-703-01	1/2 Solder Union	5.25	3.18	2.3

COMMERCIAL PRODUCTS CATALOG

Hydronic Heating Specialties

FFB (35-6A3/6H3) SERIES

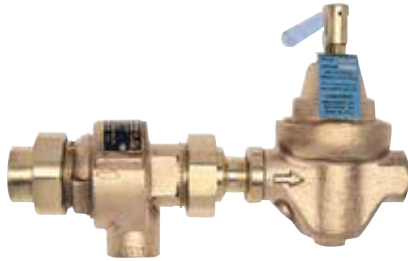

BRONZE COMBINATION CPBP BACKFLOW PREVENTER & FEED WATER REGULATORS

Positive protection against backflow when supply pressure falls below system pressure.

FEATURES

- Designed for continuous pressure, hot or cold water service
- Fast-fill lever on regulator
- Built-in Stainless Steel strainer
- Max supply pressure 100 psig
- Max temperature 210°F
- Backflow device is ASSE and CSA listed
- APOLLOXPRESS™ end connection option

Series Number	Size (in.)	Height (in.)	Length (in.)	Net Wt. (lbs.)
35-6A3-BF	1/2 Union NPT x NPT	5.25	8.50	4.5
35-6H3-BF	1/2 Solder Union x NPT	5.25	8.50	4.4
35-6A3-BFC*	1/2 Union NPT	5.25	8.50	4.5
35-6H3-BFC*	1/2 Solder Union	5.25	8.50	4.4

* "C" Models for Canadian market - Discharge port not threaded.

FCT (35-403) SERIES



MULTI-ORIFICE CONTROL VALVE

Provides flow control on tankless heaters; for delivery of 2-1/2, 3, 3-1/2, and 4 GPM. Easy adjustment.

FEATURES

- Maximum temperature: 250°F
- Maximum pressure: 150 psig

Series Number	Size (in.)	Height (in.)	Length (in.)	Net Wt. (lbs.)
35-403-01	1/2 Solder	2.11	2.00	.42

FC (35FC) SERIES



ALL BRONZE HYDRONIC FLOW CHECK VALVES

The flow check is designed to provide positive shut-off when water service is interrupted.

FEATURES

- Wear resistant metal to metal seat
- Replaceable seat assembly
- By-pass option (NPT only)
- Sweat or thread connection available
- Designed for easy maintenance
- Suitable for hot or cold water service
- Maximum working pressure: 50 psi for 3/4" - 1-1/4"
125 psig for 1-1/2" - 2"
- Maximum operating temperature: 250°F

Series Number	Size (in.)	Connection	Net Wt. (lbs.)
35-FC4-01	3/4	NPT	2.3
35-FC5-01	1	NPT	2.6
35-FC6-01	1-1/4	NPT	5.0
35-FC7-01	1-1/2	NPT	8.6
35-FC8-01	2	NPT	12.2
35-FC4-02	3/4	Sweat	11.2
35-FC5-02	1	Sweat	15.5

HYDRONIC & STEAM HEATING

Balancing Valves

BAV (58) SERIES



Provide dependable hydronic control; for use with 1/2" and 3/4" copper piping. Pressure rated to 150 psig.

FEATURES

- ASTM B584 Bronze
- EPDM o-ring seal
- Made in USA

Series Number	Size (in.)	Cv	Wt. (lbs.)
58-003-01	1/2 Solder	4	.30
58-004-01	3/4 Solder	14	.5

58A SERIES



This valve is being discontinued. Available until remaining stock is depleted.

Apollo Model 58A balance provide two position hydronic circuit isolation capability and multi-turn throttling adjustment required for proportional balancing of hydronic systems. The valve has a unique needle valve adjustment, with integrated digital readout. Available in NPT, Solder and XPress connections.

FEATURES

- DZR Brass body
- P/T plugs
- Compatible with all flow meters
- Easy adjustment and setpoint indicator
- Isolated flow shut-off does not affect adjustments
- Reversible lever
- Connection options include: Thread (-T), Solder (-S), Press (-PR)

Series Number	Size (in.)	Connection	Cv	Wt. (lbs.)
58A103 T	1/2	NPT/SWEAT/PRESS	1.79	1.1
58A104 T	3/4	NPT/SWEAT/PRESS	4.51	1.4
58A105 T	1	NPT/SWEAT/PRESS	8.18	1.8
58A106 T	1-1/4	NPT/SWEAT/PRESS	13.89	3.3
58A107 T	1-1/2	NPT/SWEAT/PRESS	23.9	4.3
58A108 T	2	NPT/SWEAT/PRESS	33.77	6.0

COMMERCIAL PRODUCTS CATALOG

Hydronic Heating Specialties

PBS (78-600) SERIES



BRONZE PURGE, BALANCE AND SHUT-OFF VALVE

Straight-through flow; all brass cover and chain prevent accidental system drainage; hose thread connection for disposal of drained media.

FEATURES

- RPTFE seals
- Adjustable packing
- 600 psig CWP in open position

Series Number	Description	Size (in.)	Net Wt. (lbs.)
78-645-01	FNPT x FNPT x Hose	1/2	2.0
78-646-01	FNPT x FNPT x Hose	3/4	2.0
78-668-01	Solder x Solder x Hose	3/4	2.0
78-668-02	Solder x Solder x Hose	1	3.5
78-671-01*	Solder x Solder x Hose	3/4	1.9

* Available with screwdriver slotted stainless steel stem.

Hydronic Valves

77C-100-94 SERIES



BALL VALVE WITH BALANCING STOP AND STEM EXTENSION

Ideal for HVAC systems. Stop plate and a 2-1/4" stem extension combination to accommodate insulation and handle repositioning.

FEATURES

- ASTM B584 Bronze
- MPTFE seats and stem packing
- Blowout-proof stem design
- Adjustable packing gland
- 600 psig CWP cold, non-shock

Contact customer service for exact handle dimensions

Series Number	LF Series Number	Size (in.)	Dimensions (in.)					Net Wt. (lbs.)
			A	B	C	D	E	
77C-101-94	77CLF-101-94	1/4"	0.37	1.07	2.09	3.84	3.74	0.83
77C-102-94	77CLF-102-94	3/8"	0.37	1.07	2.09	3.84	3.74	0.79
77C-103-94	77CLF-103-94	1/2"	0.50	1.15	2.25	3.87	3.74	0.87
77C-104-94	77CLF-104-94	3/4"	0.75	1.32	2.65	4.10	4.78	1.99
77C-105-94	77CLF-105-94	1"	1.00	1.53	3.07	4.29	4.78	2.16
77C-106-94	77CLF-106-94	1-1/4"	1.25	2.04	4.08	5.24	7.06	4.63
77C-107-94	77CLF-107-94	1-1/2"	1.50	2.21	4.43	5.40	7.06	5.03
77C-108-94	77CLF-108-94	2"	2.00	2.76	5.29	5.93	7.06	8.33

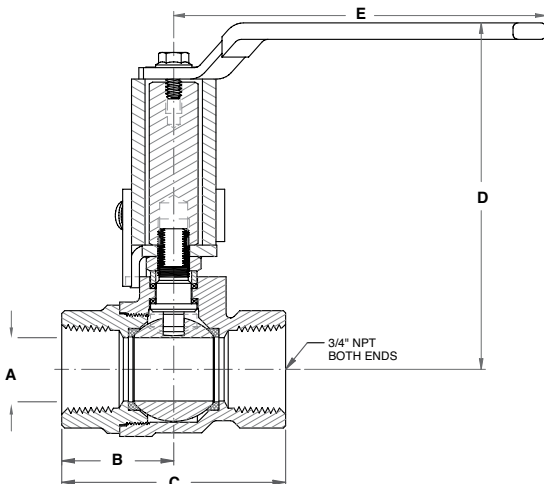

HYDRONIC & STEAM HEATING

Specialty Valves

78-970-01 SERIES

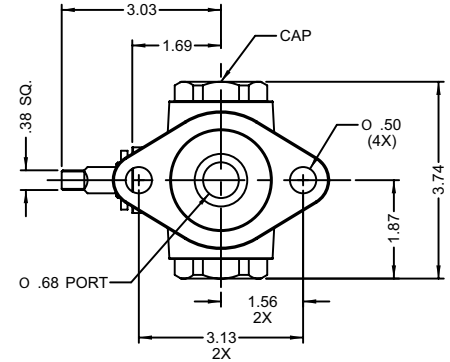
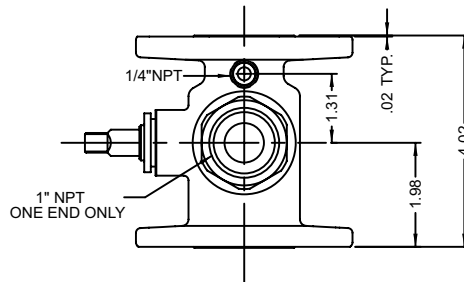

HYDRONIC 3-WAY, 4-SEATED BALL VALVE WITH FLANGED PUMP CONNECTIONS

Can be used in hydronic geothermal or other HVAC applications where diversion of flow is required, along with positive shut-off. Designed to connect directly to circulator pump flange connections.

Water Heater Accessories

EXV (78-RV) SERIES



BRONZE SHUT-OFF VALVE WITH THERMAL EXPANSION CONTROL VALVE

The Apollo® 78RV combines thermal expansion protection and water heater shut-off in a single, simple installation. They're space saving and a less costly alternative to large expansion tanks.

FEATURES

- 3/4" Solder, NPT, and Pex ball valve connections
- Corrosion resistant, all bronze materials
- Chrome plated ball
- Thermal relief valve is factory preset and sealed
- Relief valve features soft seat and Stainless Steel spring
- Relief valve available with hose barb fitting, 1/2" Pex fitting, 3/8" compression fitting or 1/2" combination sweat/thread fitting
- IAPMO IGC 128-2008 approval
- Temperature rating: 210°F max
- Meets CSA B125.1 & B125.3 requirements
- City of Los Angeles registered
- Multiple relief pressure kit options
- **Lead Free** option (78LF-RV)
 - Easily Identifiable White Handle Grip and Blue "Lead Free" Hang Tag
 - EZ-Solder™ Lead Free Bronze

Designate Lead Free by adding LF to Series No. (ex. 78LF-414-RV)

NUMBERING SYSTEM

78	-X	-X	-X	-RV
SERIES	SIZE	SET PRESSURE	RELIEF VALVE CONNECTION	
78 = Standard	3 = 3/4 SWT	0 = 125 psig	4 = 3/8" Hose barb	
78LF = Lead Free	4 = 3/4 THD	1 = 100 psig	5 = 1/2" Pex	
	7 = 3/4 PEX	2 = 80 psig	6 = 3/8" Compression fitting	
			7 = 1/2" NPT/SWT fitting	

EXAMPLES:

78-306-RV = 3/4" Sweat Connections, 125 psig Set Pressure, 3/8" Compression Connection on Relief Valve.

78LF-414-RV = Lead Free, 3/4" Threaded Connections, 100 psig Set Pressure, 3/8" Hose Barb Connection on Relief Valve.



See Hydronic & Steam Heating Catalog (PHBRHYD) for more detailed information about the products in this section.

Customer Service (704) 841-6000

COMMERCIAL PRODUCTS CATALOG

Water Heater Accessories

EXP (40-XT) SERIES



EXPANSION TANKS FOR POTABLE SYSTEMS

Designed to protect closed water supply systems, appliances and piping from the hazards of thermal expansion, such as premature water heater failure. Installs easily on direct fired gas, oil and electric hot water heaters and storage tanks. Their pre-pressurized steel design includes an expansion membrane that stops any contact between the water and air in the tank.

FEATURES

- Ideal for use in dorms, apartments, office buildings and hospitals
- Compatible with most standard water heaters and storage tanks
- Maximum working pressure: 150 psig
- Food quality Chlorobutyl diaphragm
- 100 percent non-metallic non-corrosive water reservoir
- Pre-charge pressure 40 psig
- Field adjustable pre-charge
- ANSI/NSF 61-8, Annex G (**Lead Free**)
- **Made in USA**

Series Number	Capacity (gal.)	Exp. Vol. (gal.)	Connection	Dimensions (in.)		Net Wt. (lbs.)
				Height	Diameter	
40-XT1-03	2	1.27	3/4 NPT	12.5	8.25	5.5
40-XT3-03	5	3.05	3/4 NPT	14.0	11.25	8
40-XT5-03	10	7.80	3/4 NPT	15.75	15.25	20

Vacuum Relief Valves

VR (37-200) SERIES



VACUUM RELIEF VALVES FOR WATER HEATER PROTECTION

Designed to protect tank from collapsing during water siphoning, resulting in negative pressure. Design certified by CSA in accordance with ANSI Z21.22. Also suitable for low pressure (15 psig maximum) steam service.

FEATURES

- Maximum temperature: 250°F
- Auto-vacuum relief at less than 1" Hg vacuum
- Rated for water pressures to 200 psig
- Model 37-200 brass body (EPDM rubber @2" mercury (vacuum))

Series Number	Size (in.)	Venting Capacity	Wt./100 (lbs.)
37-201	1/2	15 CFM	30.4
37-202	3/4	16 CFM	32.4

Suffix key: Satin Brass - 01; Satin Chrome - 02

*NOTE: These valves are not designed for anti-siphon backflow prevention. To prevent back-siphonage of polluted water into a potable water system, choose from Conbraco's line of backflow preventers.



MIXING VALVES

MIXING VALVES



See Mixing Valve Catalog (PHBRMIX) for more detailed information about the products in this section.



MIXING VALVES

Hydronic Tempering Valves

TV (34-200) SERIES



MIXING VALVES

These dependable thermostatic mixing valves are designed to provide non-ASSE extension of water heater capacity and hot water temperature control in residential hot water heater and hydronic heating applications. Numbered indicator control allows easy setup and fingertip control. Available in low or high temperature options depending on floor or baseboard application.

FEATURES

- Low temperature range (85°-120°F)
- Standard temperature range (120°-180°F)
- Made in USA
- Corrosion resistant bronze body
- Thermoplastic shuttle assembly
- Solder connections are standard
- Hot & cold water failure protection

Size (in.)	Connection	Low Temp (85° - 120°F)		Standard Temp (120° - 180°F)	
		Model	Series	Model	Series
1/2	Solder	TV12L1	34-203-L1	TV12	34-203-01
3/4	Solder	TV34L1	34-204-L1	TV34	34-204-01

To order Repair Kits use part numbers 34-200-01RK (high temp.), 34-200-L1RK (low temp.)

- Not intended for potable water

COMMERCIAL PRODUCTS CATALOG

ASSE 1017 Point of Source Mixing Valves

MVA (34ALF) SERIES



THERMOSTATIC MIXING VALVES

34A Series are ASSE 1017 certified mixing valves designed for hot water distribution systems; or "point of source" applications. High temperature versions are designed for radiant heat applications, to provide better control of hot water supply. Numbered indicator control allows easy setup and fingertip control. Available in standard or high temperature range options depending on application. Inlet check valves and Stainless Steel screens provide added protection of thermostat and cross flow control.

FEATURES

- New EPDM union washer/screen
- Standard temperature range (85°-140°F)
- High temperature range (120°-180°F)
- Corrosion resistant bronze body
- Supply pressures to 150 psig
- Union NPT, Solder, CPVC, Press and PEX connections
- Inlet check valves
- 30 mesh SS screens on both inlets
- High flow capacity
- Broad temperature adjustment range
- Hot and cold water failure protection
- CSA B125.3 approval
- Calibrated max 120°F setpoint option available
- Chloramine resistant elastomers
- Maximum flow 19 gpm @ 30 psid
- NSF/ANSI 372 Lead Free
- Non-Lead Free remain available and can be ordered (34Axxxxx)

Size (in.)	Connection	Standard Temp (85° - 140°F)		Cal. Max. Temp (120°F)		Radiant	
		Model	Series	Model	Series	High Temp (120° - 180°F)*	
						Model	Series
1/2"	Solder inlets X Solder outlet	MVAS12	34ALF213S	MVABS12	34ALF213BS	MVAHS12	34ALF213HS
	FNPT inlets X FNPT outlet	MVA12	34ALF213T	MVAB12	34ALF213BT	MVAHT12	34ALF213HT
	CPVC inlets X CPVC outlet	MVAC12	34ALF213C	MVABC12	34ALF213BC		
	PEX inlets X PEX outlet	MVAX12	34ALF213X	MVABX12	34ALF213BX		
	Solder inlets X CPVC outlet	MVASC12	34ALF213SC	MVABSC12	34ALF213BSC		
	FNPT inlets X CPVC outlet	MVATC12	34ALF213TC	MVABTC12	34ALF213BTC		
	PEX inlets X CPVC outlet	MVAXC12	34ALF213XC	MVABXC12	34ALF213BXC		
	CPVC inlets X PEX outlet	MVACX12	34ALF213CX	MVABCX12	34ALF213BCX		
3/4"	PRESS inlets X PRESS outlet	MVAPR12	34ALF213PR	MVABPR12	34ALF213BPR		
	Solder inlets X Solder outlet	MVAS34	34ALF214S	MVABS34	34ALF214BS	MVAHS34	34ALF214HS
	FNPT inlets X FNPT outlet	MVA34	34ALF214T	MVAB34	34ALF214BT	MVAHT34	34ALF214HT
	CPVC inlets X CPVC outlet	MVAC34	34ALF214C	MVABC34	34ALF214BC		
	PEX inlets X PEX outlet	MVAX34	34ALF214X	MVABX34	34ALF214BX		
	Solder inlets X CPVC outlet	MVASC34	34ALF214SC	MVABSC34	34ALF214BSC		
	FNPT inlets X CPVC outlet	MVATC34	34ALF214TC	MVABTC34	34ALF214BTC		
	PEX inlets X CPVC outlet	MVAXC34	34ALF214XC	MVABXC34	34ALF214BXC		
1"	CPVC inlets X PEX outlet	MVACX34	34ALF214CX	MVABCX34	34ALF214BCX		
	PRESS inlets X PRESS outlet	MVAPR34	34ALF214PR	MVABPR34	34ALF214BPR		
	Solder inlets X Solder outlet	MVAS1	34ALF215S	MVABS1	34ALF215BS	MVAHS1	34ALF215HS
	FNPT inlets X FNPT outlet	MVA1	34ALF215T	MVAB1	34ALF215BT	MVAHT1	34ALF215HT
	CPVC inlets X CPVC outlet	MVAC1	34ALF215C	MVABC1	34ALF215BC		
	PEX inlets X PEX outlet	MVAX1	34ALF215X	MVABX1	34ALF215BX		
	Solder inlets X CPVC outlet	MVASC1	34ALF215SC	MVABSC1	34ALF215BSC		
	FNPT inlets X CPVC outlet	MVATC1	34ALF215TC	MVABTC1	34ALF215BTC		
1"	PEX inlets X CPVC outlet	MVAXC1	34ALF215XC	MVABXC1	34ALF215BXC		
	CPVC inlets X PEX outlet	MVACX1	34ALF215CX	MVABCX1	34ALF215BCX		
1"	PEX inlets X PEX outlet	MVAPR1	34ALF215PR	MVABPR1	34ALF215BPR		
	PRESS inlets X PRESS outlet						

To order Repair Kits use part numbers 34A200HRK (high temp.), 34A200RK (std. temp.)

* High temperature models are not ASSE certified.

MIXING VALVES

Mixing Valves

MVC (34C) SERIES



COMMERCIAL HIGH CAPACITY MIXING VALVES

34C Series ASSE 1017 listed, high-capacity mixing valves are thermostatically controlled regulating valves designed for use in large commercial potable and non-potable hot water systems or "point of source" applications. Simple adjustment of water temperature from 90°-140°F or 130°-180°F.

FEATURES

- Sizes: 3/4", 1", 1-1/4", 1-1/2", 2"
- Standard temp range (90°-140°F)
- High temp range (130°-180°F)
- Threaded connections
- Installs easily on heating source
- Chloramine resistant elastomers
- Patented design for easy in-line maintenance
- Supply pressures to 150 psig
- U. S. Patent No. 6,328,219
- CSA B125.3

To order Repair Kits:

- 3/4" - 1" - 34C104RK (std. temp)
- 34C104R1 (high temp)
- 1-1/4" - 2" - 34C106RK (std. temp)
- 34C106RK1 (high temp)

Size (in.)	Connection	Standard Temp (90° - 140°F)		High Temp (130° - 180°F)*	
		Model	Series	Model	Series
3/4"	FNPT inlets X FNPT outlet	MVC34	34C10401	MVCH34	34C104H1
		MVCLF34	34CLF10401	MVCLFH34	34CLF104H1
1"		MVC1	34C10501	MVCH1	34C105H1
		MVCLF1	34CLF10501	MVCLFH1	34CLF105H1
1-1/4"		MVC114	34C10601	MVCH114	34C106H1
		MVCLF114	34CLF10601	MVCLFH114	34CLF106H1
1-1/2"		MVC112	34C10701	MVCH112	34C107H1
		MVCLF112	34CLF10701	MVCLFH112	34CLF107H1
2"		MVC2	34C10801	MVCH2	34C108H1
		MVCLF2	34CLF10801	MVCLFH2	34CLF108H1

* High temperature models are not ASSE certified.

Point of Use Mixing Valves

MVD (34D) SERIES



**34D Single Outlet
"Point Of Use" Mini Mixer**



MINI-MIXER MIXING VALVES

ASSE 1070 certified, "point of use" mixing valves are designed to sense and maintain preset outlet temperature compensating for fluctuations in hot and cold water supply temperatures and pressures. The mixed water temperature adjustment range is 85°F to 120°F and will hold a desired temperature within ±2°F. The 34D also features an adjustable temperature limit stop to prevent the valve from being set above 120°F.

FEATURES

- Corrosion resistant bronze body
- 3/8" compression connections
- Easy maintenance
- Elevated temperature thermal element protection
- CSA B125.3 approval
- Mounting kit included
- Chrome plate option
- Can be used with 3/8" braided hose
- Tamper resistant locking cap
- Scald protection
- Inlet check valves to prevent cross connection
- Bypass tee option for cold water connections
- Chloramine resistant elastomers
- Hot & cold water failure protection
- **Lead Free** option (34DLF)
 - NSF/ANSI 61-8 approval
 - NSF/ANSI 372 Lead Free

Size (in.)	Connection	Finish	Single Inlet		By-Pass Inlet	
			Model	Series	Model	Series
3/8"	Compression inlets X Compression outlet	Bronze	MVD	34D30201	MVDB	34D302B1
		Chrome Plated	MVDR	34D30217	MVDRB	34D302B17
3/8"	Compression inlets X Compression outlet	Bronze	MVD	34DLF30201	MVDB	34DLF302B1
		Chrome Plated	MVDR	34DLF30217	MVDRB	34DLF302B17

To order Repair Kits use part number 34D300RK.



See Mixing Valve Catalog (PHBRMIX) for more detailed information about the products in this section.

Customer Service (704) 841-6000

REV. 9/24/14

103

COMMERCIAL PRODUCTS CATALOG

Dual Purpose Mixing Valves

MVB (34B) SERIES



SCALD PROTECTION MIXING VALVES

ASSE 1017 and 1070 certified mixing valves are designed for “point of source” or “point of use” applications with high flow. These valves use a thermostatic element that senses outlet temperature and will compensate for fluctuating inlet temperature and pressure. The mixed water temperature range is 85°-120°F and will hold a desired temperature within $\pm 3^\circ\text{F}$. The 34B also features adjustable temperature limit stop to prevent the valve from being set above 120°F.

FEATURES

- High flow rates
- Stainless steel spring
- Corrosion resistant bronze body
- NPT, Solder, Pex, CPVC connections
- CSA B125.3 approval
- ASSE 1017 for hot water source apps.
- ASSE 1070 for multiple fixture apps.
- Inlet check valves
- New flat EPDM union washers with 20 mesh screen
- Cold water failure protection
- Adjustable temperature limit stop
- Supply pressures to 150 psig
- Tamper resistant locking cap
- Chloramine resistant elastomers
- 1.5 GPM minimum flow rate
- For lower flow applications recirculation pump downstream is recommended
- **Lead Free** option (34BLF)

Size (in.)	Connection	Model	Series	LF Series
1/2"	Solder inlets X Solder outlet	MVBS12	34B213S	34BLF213S
	FNPT inlets X FNPT outlet	MVB12	34B213T	34BLF213T
	CPVC inlets X CPVC outlet	MVBC12	34B213C	34BLF213C
	PEX inlets X PEX outlet	MVBX12	34B213X	34BLF213X
	Solder inlets X CPVC outlet	MVBSC12	34B213SC	34BLF213SC
	FNPT inlets X CPVC outlet	MVBTC12	34B213TC	34BLF213TC
	PEX inlets X CPVC outlet	MVBXC12	34B213XC	34BLF213XC
	CPVC inlets X PEX outlet	MVBCX12	34B213CX	34BLF213CX
3/4"	Solder inlets X Solder outlet	MVBS34	34B214S	34BLF214S
	FNPT inlets X FNPT outlet	MVB34	34B214T	34BLF214T
	CPVC inlets X CPVC outlet	MVBC34	34B214C	34BLF214C
	PEX inlets X PEX outlet	MVBX34	34B214X	34BLF214X
	Solder inlets X CPVC outlet	MVBSC34	34B214SC	34BLF214SC
	FNPT inlets X CPVC outlet	MVBTC34	34B214TC	34BLF214TC
	PEX inlets X CPVC outlet	MVBXC34	34B214XC	34BLF214XC
	CPVC inlets X PEX outlet	MVBCX34	34B214CX	34BLF214CX
1"	Solder inlets X Solder outlet	MVBS1	34B215S	34BLF215S
	FNPT inlets X FNPT outlet	MVB1	34B215T	34BLF215T
	PEX inlets X PEX outlet	MVBX1	34B215X	34BLF215X

To order Repair Kits use part number 34B200RK.

MIXING VALVES

Automatic Temperature Controller

MVHL (34HL) SERIES



STANDARD APPROVALS

ASSE 1069 - Automatic Temperature Control Mixing Valves

This device will control outlet water temperature to individual or multiple fixtures within 3.6°F to reduce the risk of scalding or thermal shock. This device is intended to be installed where the bather has no access to the temperature adjustment, and where no further mixing occurs downstream of the device.

The Apollo 34HL ATC will meet the performance requirements of ASSE 1069 at flow as low as 1.5 GPM up through maximum flow rate.

ASSE 1017 - Temperature Actuated Mixing Valves for Hot Water Distribution Systems

This device will control outlet set water temperature to hot water distribution systems near the hot water source within 3°F below 2 GPM and within 5°F above 5 GPM.

INNOVATION FROM APOLLO®...THE FIRST MULTIPLE-FIXTURE HI-LO MIXING VALVE THAT MEETS ASSE 1017 AND THE NEW ASSE 1069 STANDARD

Only Apollo® offers fast delivery on the first water temperature mixing assembly to meet ASSE 1017 and the strict performance levels required by the new ASSE 1069 Standard.

The new 34HL Automatic Temperature Control Mixing Valve uses proven Apollo thermostatic control to produce a consistent mix of water from low through high flow range.

This single assembly controls mixed water temperatures to multiple-outlet shower and sink installations. It's the ideal choice in new construction or retrofits in nursing homes, prisons, hospitals, schools, gymnasiums, airports and other facilities where constant safe water temperature needs to be maintained at several outlets without the use of independent ASSE 1016 shower valves.

FEATURES

- The Apollo 34HL Automatic Temperature Controller is an advanced thermostatic mixing valve capable of maintaining safe, consistent temperature control of water at low and high flows to within $\pm 3.6^\circ$ F.
- The 34HL will provide consistent temperature control at flow rates as high as 60 GPM and as low as 1.5 GPM, including mid-range flow between high and low.
- This high quality Apollo valve performs its function without requiring recirculation pumps like other systems in order to achieve low flow control.
- Integral strainers and checks are provided at the hot and cold supply inlets for greater reliability and performance.
- These cast bronze thermostatic mixing valves are manufactured to the same exacting standards that have made the Apollo name famous for durability and reliability.

PRODUCT SPECIFICATIONS

Maximum Static Pressure	150 psig (1034 kpa)
Maximum Water Temperature	200° F (93° C)
Minimum ASSE 1017 Flow	0.5 gpm (1.9 lpm)
Minimum ASSE 1069 Flow	1.5 gpm (5.7 lpm)
Temperature Adjustment Range	90° F - 140° F
Maximum Inlet Pressure Differential	30 psi (207kpa)
Inlet Connection	1" NPT
Outlet Connection	1-1/4" NPT
Temperature Gauge	0-200°F
Pressure Gauge	0-160 psi
Shipping Weight	36 lbs

OPTIONS

34HL10517	Nickel plated
34HLBOX01	Cabinet, flush mount, SS
34HLBOX02	Cabinet, flush mount, CS powder coat
34HLBOX03	Cabinet, wall mount, SS
34HLBOX04	Cabinet, wall mount, CS powder coat

COMMERCIAL PRODUCTS CATALOG

Automatic Temperature Controller

MVHL (34HL) SERIES (CONT.)

OPERATION

- The 34HL design is patented with a variable fluid flow assembly and dual thermal actuated controls for either low or high flow conditions.
- The passages are calibrated to control water temperature during all flow conditions without a “dead zone” between low and high flow.
- The 34HL also provides fluid shutoff as required by ASSE 1069 in the case that either the hot or cold supply lines fail (or are shut off for any reason) to prevent scalding or thermal shock.
- The valve can be tamper-resistant to limit the water temperature from exceeding safe conditions as required by ASSE 1069.
- The valve also meets the requirements of ASSE 1017 for Point of Source Applications.

This device will service end-use fixture fittings, including but not limited to, gang showers and sitz baths, by supplying tempered water at a preset temperature through a single supply pipe and will meet ASSE standard 1069 2005. ASSE 1069 devices are designed to reduce the risk of scalding and thermal shock during changes in hot or cold water supply pressure or temperature, or loss of cold water supply.

Model	Series	Min. Flow to ASSE 1069	Pressure Drop Across Valve			
			10 psi (69 kpa)	20 psi (138 kpa)	30 psi (207 kpa)	45 psi (310 kpa)
MVHL1	34HL10501	1.5 gpm	22 gpm	42 gpm	52 gpm	60 gpm
		6 lpm	83 lpm	159 lpm	197 lpm	227 lpm

Figure 1: Typical Valve Dimensions with Stainless Steel Recessed Cabinet Option

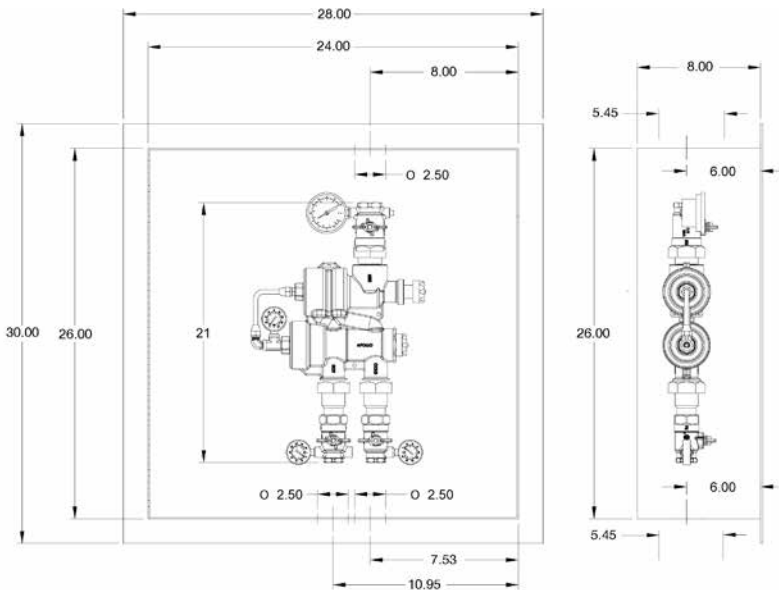

To order Repair Kits:

- Major (low side) – 34HL105RKL1
- O-Ring (low side) – 34HL105RKL2
- Handle – 34HL105RKH
- Major (high side) – 34HL105RKH1
- O-Ring (high side) – 34HL105RKH2

OPTIONS:

- 34HL10517 - Nickel plated automatic temperature controller
- 34HLBOX01 - Cabinet, flush mount, SS
- 34HLBOX02 - Cabinet, flush mount, CS powder coat
- 34HLBOX03 - Cabinet, wall mount, SS
- 34HLBOX04 - Cabinet, wall mount, CS powder coat

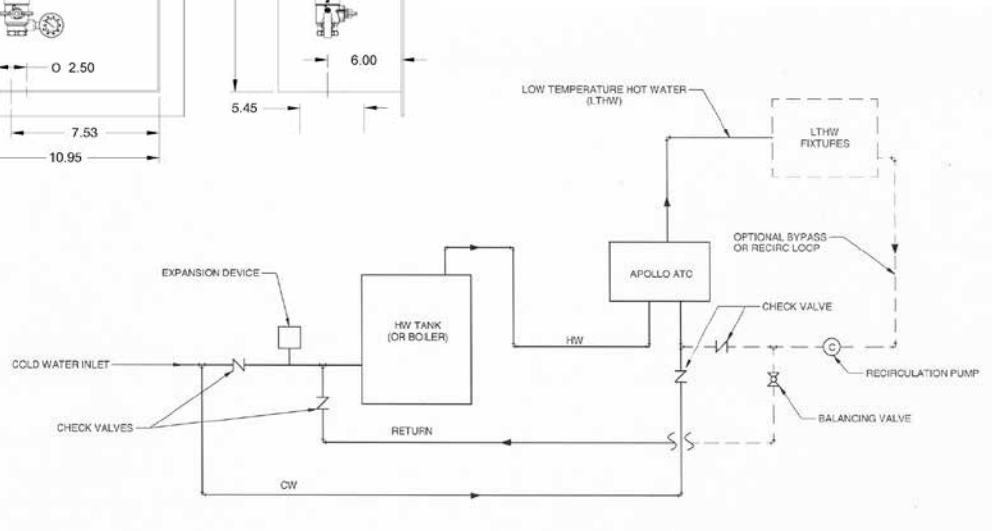

Figure 2: Typical Installation with Optional Recirculation Loop

MIXING VALVES

Emergency Eye Wash/Face Wash Mixing Valve

MVE (34ELF) SERIES



MVE 34E EMERGENCY MIXING VALVE

Designed to control the cold and hot water temperature to deliver tepid water at a predetermined temperature to emergency eyewash/facewash fixtures. The device provides a precise temperature and flow control in the event of cold water, hot water and thermostatic element failures.

FEATURES

- Hot & cold water supply failure protection patented design
- Tepid water temperature limit control and adjustment
- Tepid water temperature adjustment handle with locking mechanism for tamper-resistant protection
- Integral inlet check valves and strainers
- Superior thermostatic element technology for optimum reliability and dependability
- Thermostatic element failure and over travel protection
- High efficiency and positive shut-off check valves
- In-line accessibility and serviceability of failure protection module and mixing valve internal components
- ASSE 1071 approved
- Meets ANSI/ISEA Z358.1-2009
- Meets requirements of the EPA Safe Drinking Water Act
- Corrosion resistant components
- Model 34E with standard bronze construction is still available

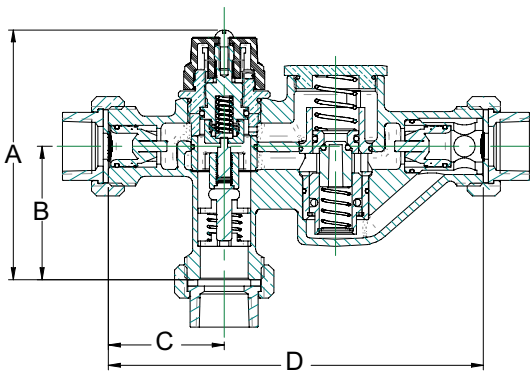

LF Model Number	LF Series Number	Connection	Dimensions (in.)				
			A	B	C	D	E
MVE-12LF	34ELF103T	1/2" NPT	4.72	2.52	2.19	7.09	1.87
MVES-12LF	34ELF103S	1/2" Solder	4.72	2.52	2.19	7.09	1.87
MVE-34LF	34ELF104T	3/4" NPT	4.72	2.52	2.19	7.09	1.87
MVES-34LF	34ELF104S	3/4" Solder	4.72	2.52	2.19	7.09	1.87

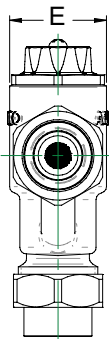

TYPICAL INSTALLATIONS

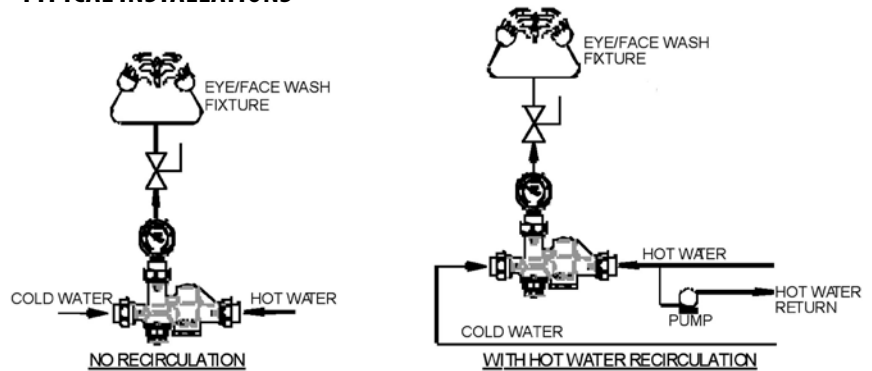

COMMERCIAL PRODUCTS CATALOG



WATER PRESSURE REDUCING VALVES



WATER PRESSURE REDUCING VALVES



See *Water Pressure Reducing Valves Catalog (PHBRWPRV)* for more detailed information about the products in this section.

WATER PRESSURE REDUCING VALVES

Water Pressure Reducing Valves

PR (36LF) SERIES



RESIDENTIAL AND COMMERCIAL APPLICATIONS

The Apollo® 36LF pressure reducing valves reduce wasteful high supply pressures to lower manageable pressures. Factory set at 50 psig.

FEATURES

- Nitrile diaphragm (FDA grade) rated to 180°F Max.
- Corrosion resistant bronze body and cover construction
- No cage screws to rust
- Meets ASSE and CSA standards
- Listed with IAPMO
- Integral high-capacity SS strainer
- Maximum supply pressure 300 psi
- City of Los Angeles approved
- Replaceable cartridge
- Available in sizes from 1/2" to 2"
- Integral thermal expansion by-pass
- **Made in USA**
- NSF/ANSI 372 Lead Free
- Standard materials remain available for irrigation, industrial, & international applications. May be ordered as 36-xxx-xx.

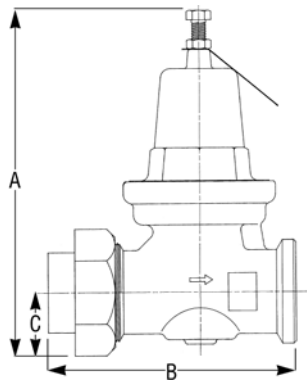

Pipe Thread Union x FNPT	Solder Joint Union x FNPT	CPVC Union x FNPT	Size (in.)	Dimensions (in.)			Wt./100 (lbs.)
				A	B	C	
36LF-103-01	36LF-303-01		1/2	6.12	4.62	1.00	350
36LF-104-01	36LF-304-01	36LF-3C4-01	3/4	6.12	4.62	1.00	340
36LF-105-01	36LF-305-01	36LF-3C5-01	1	6.50	5.12	1.12	450
36LF-106-01	36LF-306-01		1-1/4	8.62	6.37	1.37	1020
36LF-107-01	36LF-307-01		1-1/2	8.62	6.62	1.37	1045
36LF-108-01	36LF-308-01		2	11.75	8.44	1.81	2250

FNPT x FNPT (no union)							
Pipe Thread Union x FNPT	Solder Joint Union x FNPT	CPVC Union x FNPT	Size (in.)	Dimensions (in.)			Wt./100 (lbs.)
				A	B	C	
36LF-203-01			1/2	6.12	3.69	1.00	311
36LF-204-01			3/4	6.12	3.69	1.00	305
36LF-205-01			1	6.50	4.06	1.12	415
36LF-206-01			1-1/4	8.62	5.19	1.37	910
36LF-207-01			1-1/2	8.62	5.31	1.37	909
36LF-208-01			2	11.75	7.12	1.81	1880

Double Union FNPT x FNPT	Double Union Solder x Solder	Double Union CPVC x CPVC	Size (in.)	Dimensions (in.)			Wt./100 (lbs.)
				A	B	C	
36LF-403-01	36LF-503-01		1/2	6.12	5.81	1.00	389
36LF-404-01	36LF-504-01	36LF-5C4-01	3/4	6.12	5.81	1.00	372
36LF-405-01	36LF-505-01		1	6.50	6.50	1.12	495
36LF-406-01	36LF-506-01		1-1/4	8.62	7.69	1.37	1090
36LF-407-01	36LF-507-01		1-1/2	8.62	8.00	1.37	1183
36LF-408-01	36LF-508-01		2	11.75	10.06	1.81	2472
36LF-904-01	Pex x Pex		3/4	6.12	5.81	1.00	372
36LF-9C4-01	Union CPVC	Pex Union	3/4	6.12	5.81	1.00	372

PART NUMBER MATRIX

36LF	X	X	X	X	X	X
CONNECTION	OPTIONS	SIZE	GAUGE	PRESSURE (ADJUSTABLE)	OPTION	
1 - Single Union NPT	0 - No Option	03 - 1/2"	0 - No Gauge	1 - 25-75 psig	PR - Press	
2 - No Union NPT	C - CPVC Tailpiece	04 - 3/4"	P - With Gauge Port	2 - 10-35 psig	(applies to models 36-20x and 36LF20x only)	
3 - Single Union Solder x NPT	S - Sealed Cage*	05 - 1"	G - With Gauge	3 - 75-125 psig		
4 - Double Union NPT	X - Pex Tailpiece	06 - 1-1/4"				
5 - Double Union Solder		07 - 1-1/2"				
6 - Single Union Meter x NPT		08 - 2"				
8 - Double Union CPVC						
9 - Double Union Pex						

* S option = Sealed cage with stainless steel adjusting screw for vault installation.



See Water Pressure Reducing Valves Catalog (PHBRWPRV) for more detailed information about the products in this section.

Customer Service (704) 841-6000

COMMERCIAL PRODUCTS CATALOG

Water Pressure Reducing Valves

PRC (36CLF) SERIES



RESIDENTIAL AND COMMERCIAL APPLICATIONS

The Apollo® 36CLF reduces wasteful high supply pressures to lower manageable pressures. All-bronze body, dielectric polymer cage, stainless steel strainer and trim. In line repairable with bottom access without disturbing pressure setting.

FEATURES

- EPDM FDA grade diaphragm
- Standard factory setting: 50 psi
- Adjusts from 25 to 75 psi (standard)
- Sealed cage with stainless steel adjusting screw
- Balanced piston design
- Built-in thermal expansion by-pass
- Integral SS strainer
- 400 psi max. supply pressure
- Single or double union, female NPT, PEX, CPVC, Press, or solder-joint connections
- ASSE 1003 & CSA B356
- IAPMO listed
- City of Los Angeles approved
- NSF 372 Lead Free
- Standard materials available as 36C option
- **Made in USA**

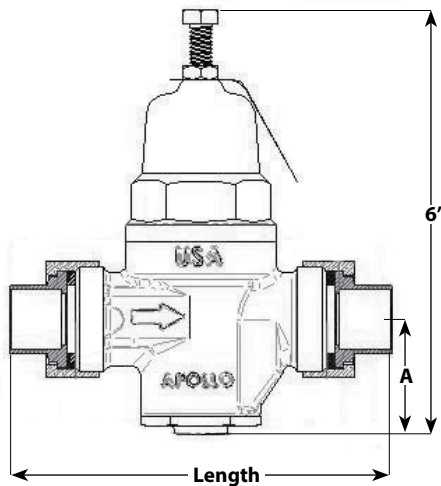

Series Number	LF Series Number	Size (in.)	Dimensions (in.)		Wt./100 (lbs.)
			Length	A	
FNPT Inlet x Outlet (no union)					
36C-203	36CLF-203	1/2	3.50	1.62	200
36C-204	36CLF-204	3/4	3.50	1.62	200
36C-205	36CLF-205	1	3.75	1.50	225
FNPT Union Inlet x FNPT Outlet					
36C-103	36CLF-103	1/2	4.41	1.62	240
36C-104	36CLF-104	3/4	4.41	1.62	240
36C-105	36CLF-105	1	4.75	1.50	270
Sweat Union Inlet x FNPT Outlet					
36C-303	36CLF-303	1/2	4.41	1.62	240
36C-304	36CLF-304	3/4	4.75	1.62	240
36C-305	36CLF-305	1	4.41	1.50	270
CPVC Union Inlet x FNPT Outlet					
36C-304-01C	36CLF-304-01C	3/4	4.75	1.62	240
36C-305-01C	36CLF-305-01C	1	4.41	1.50	270
Double Union/Threaded Inlet x Threaded Outlet					
36C-403	36CLF-403	1/2	5.37	1.62	280
36C-404	36CLF-404	3/4	5.37	1.62	280
36C-405	36CLF-405	1	5.87	1.50	310
Double Union/Sweat Inlet x Sweat Outlet					
36C-503	36CLF-503	1/2	5.37	1.62	280
36C-504	36CLF-504	3/4	5.37	1.62	280
36C-505	36CLF-505	1	5.87	1.50	310
Double Union CPVC Inlet x CPVC Outlet					
36C-504-01C	36CLF-504-01C	3/4	5.37	1.62	280
36C-505-01C	36CLF-505-01C	1	5.87	1.50	310
Double Union/PEX Inlet x PEX Outlet					
36C-903	36CLF-903	1/2	5.625	1.62	280
36C-904	36CLF-904	3/4	5.625	1.62	280
36C-905	36CLF-905	1	6.125	1.62	285

PART NUMBER MATRIX

36C				
36CLF	X	X	X	X
CONNECTION	SIZE	GAUGE	PRESSURE (ADJUSTABLE)	OPTION
1 - Single Union NPT	03 - 1/2"	0 - No Gauge	1 - 25-75 psig	C - CPVC Tailpiece
2 - No Union NPT	04 - 3/4"	P - With Gauge Port Plugged	2 - 10-35 psig	X - Extended Union
3 - Single Union Solder x NPT	05 - 1"	G - With Gauge	3 - 75-125 psig	PR - Press
4 - Double Union NPT				
5 - Double Union Solder				
6 - Single Union Meter				
9 - Double Union Pex				

www.apollovalves.com

Customer Service (704) 841-6000



WATER PRESSURE REDUCING VALVES

Water Pressure Reducing Valves

PRE (36ELF) SERIES

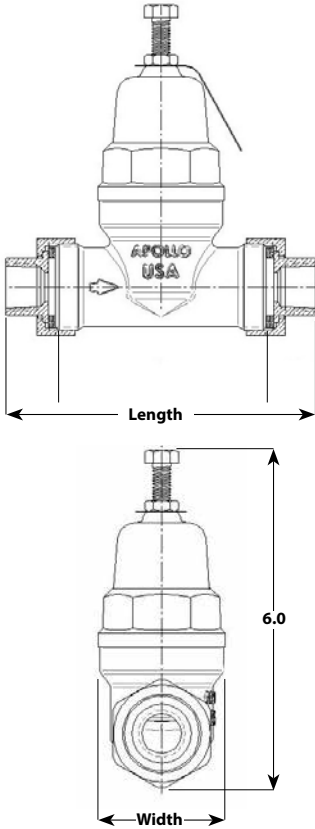

SUPER EFFICIENT RESIDENTIAL AND COMMERCIAL APPLICATIONS

The Apollo® 36ELF is designed to protect residential and commercial water supplies by automatically reducing elevated supply pressures. The streamlined dezincification resistant bronze body and dielectric polymer cage provide maximum corrosion resistance. Designed for easy in-line servicing with simple cartridge removal.

FEATURES

- High efficiency flow
- Balanced piston design
- Sealed cage for vault installations
- Built-in thermal expansion by-pass
- Integral stainless steel strainer
- SS adjusting screw and nut
- Control pressure ranges: 15-75 psi and 75-150 psi
- Maximum supply pressure: 400 psig
- Working temperature range: 33°F - 180°F
- NSF 372 Lead Free
- Standard materials available as 36C option
- 100% manufactured in USA

Size	Connection	No Union Length (in.)	Single Union Length (in.)	Double Union Length (in.)	Width (in.)	WT. (Union) (lbs)
1/2	Thread	3.63	4.50	5.38	2.75	2.4
	Solder	3.63	4.50	5.50	2.75	2.4
	PEX	3.63	4.50	5.50	2.75	2.4
	CPVC	3.63	4.25	5.00	2.75	2.4
	XPress	5.6	4.6	5.48	2.75	2.4
	Push	5.7	N/A	N/A	2.75	2.4
3/4	Thread	3.63	4.50	5.50	2.75	2.4
	Solder	3.63	4.50	5.50	2.75	2.4
	PEX	3.63	4.63	5.63	2.75	2.4
	CPVC	3.63	4.50	5.50	2.75	2.4
	XPress	5.6	4.6	5.79	2.75	2.4
	Push	5.7	N/A	N/A	2.75	2.4
1	Thread	3.63	4.63	5.75	3.38	2.7
	Solder	3.63	4.63	5.75	3.38	2.7
	PEX	3.63	4.75	6.00	3.38	2.7
	CPVC	3.63	4.75	6.00	3.38	2.7
	XPress	5.8	4.6	5.91	3.38	2.7
	Push	5.8	N/A	N/A	3.38	2.7

Pipe Size (in.)	Fall Off* (PSI)	Pressure Differential (PSI)		
		25	50	75
Water Capacity (GPM)				
1/2"	10	10	13	16
	15	13	18	22
	20	17	23	29
	30	22	29	36
3/4"	10	16	21	26
	15	20	27	32
	20	24	32	40
	30	29	38	48
1"	10	25	33	41
	15	30	42	52
	20	34	45	56
	30	35	47	59

* Fall Off is the difference between the PRV's set pressure and the flowing pressure at any given demand.

PART NUMBER MATRIX

36E						
36ELF -						
	1	X	X	X	X	X
	STYLE	UNION	SIZE	PRESSURE	CONNECTION	OPTION
36E -Standard	1	0 - No Union (NPT)	3 - 1/2"	01 - 15-75 psig	T - FNPT Thread	B - Bronze
36ELF -Lead Free		1 - Single Union	4 - 3/4"	03 - 75-150 psig	S - Solder	Cap
		2 - Double Union	5 - 1"		C - CPVC	
					P - Push	
					X - PEX	
					PR - Press	

EXAMPLES:

36ELF-114-01T = 3/4" Single Union with NPT Connections, Lead Free, 15-75 psig.
36ELF-124-01S = 3/4" Double Union with Solder Connections, Lead Free, 15-75 psig.



See Water Pressure Reducing Valves Catalog (PHBRWPRV) for more detailed information about the products in this section.

Customer Service (704) 841-6000

COMMERCIAL PRODUCTS CATALOG

Water Pressure Reducing Valves

PRE (36ELF) SERIES

Available Fall 2014!

NEW



SUPER EFFICIENT RESIDENTIAL AND COMMERCIAL APPLICATIONS

The new Apollo® Lead Free Pressure Reducing Valve Model PRE (36ELF Series) is designed to protect residential and commercial water distribution systems by automatically reducing excessive supply pressures. The dezincification resistant bronze body, stainless steel adjusting screw and dielectric polymer cage provide maximum corrosion resistance. Designed for easy in-line servicing with simple cartridge removal.

FEATURES

- NSF/ANSI 61
- NSF/ANSI 372 LeadFree
- Balanced Piston Design
- Sealed Cage for vault installations
- Built-in Thermal Expansion By-Pass
- Large Area Integral Stainless Steel Strainer
- Modular Seat Disc and Strainer Cartridge
- Polymer cage is standard
Bronze cage is optional (-B)
- Control Pressure Ranges: 15-75 psi and 75-150 psi
- Working Temp. Range: 33°F – 180°F
- High flow / high efficiency design
- NPT and Solder connections
- Factory tested and preset at 60 psi
- **100% Manufactured in USA – ARRA Compliant**
- ASSE 1003, CSA 356

OPTIONS

- 36E with standard material for non-potable applications
- -P Tapped 1/4" NPT & plugged
- -G With pressure gauge
- -B Bronze cage option

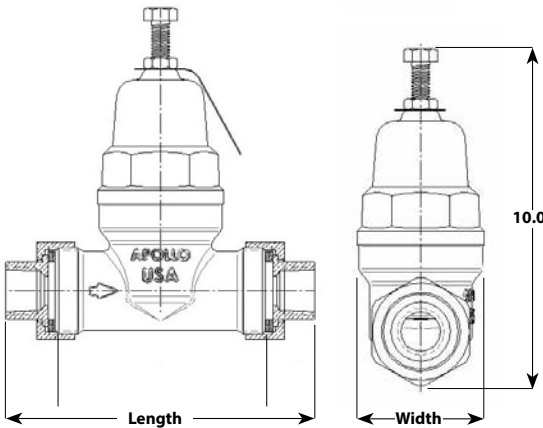

Pipe Size (in.)	Fall Off* (PSI)	Pressure Differential (PSI)		
		25	50	75
Water Capacity (GPM)				
1-1/4"	10	35	47	59
	15	58	77	96
	20	85	113	141
	30	99	132	165
1-1/2"	10	66	88	110
	15	81	108	135
	20	96	128	160
	30	104	138	172
2"	10	81	108	135
	15	109	145	181
	20	116	155	194
	30	128	170	212

Size	Connection	No Union Length (in.)	Single Union Length (in.)	Double Union Length (in.)	Width (in.)	Polymer - WT. (Union) (lbs)
1-1/4	Thread	5.50	4.63	5.75	3.38	4.5
	Solder	5.50	4.63	5.75	3.38	4.4
1-1/2	Thread	5.50	4.75	6.00	3.38	4.3
	Solder	5.50	4.75	6.00	3.38	4.0
2	Thread	5.50	4.63	5.75	3.38	4.5
	Solder	5.50	4.63	5.75	3.38	4.4

Nominal dimensions are shown. Allowances must be made for manufacturers' tolerances.

* Fall Off is the difference between the PRV's set pressure and the flowing pressure at any given demand.

PART NUMBER MATRIX

36ELF - 36E -	1	X	X	X	X	X	X
	STYLE	UNION	SIZE	GAUGE	PRESSURE	CONNECTION	OPTION
36ELF -Lead Free	1	0 - No Union (NPT)	6 - 1-1/4"	0 - No gauge	1 - 15-75 psig	T - FNPT Thread	Blank -
36E -Standard		1 - Single Union	7 - 1-1/2"	P - Tapped & Plugged	3 - 75-150 psig	S - Solder	Polymer Cap
		2 - Double Union	8 - 2"	G - With gauge			B - Bronze Cap

EXAMPLE:

36ELF-116-01T = Lead Free 1-1/4" Single Union with NPT Connections, Pressure Range 15-75 psig.

WATER PRESSURE REDUCING VALVES

Water Pressure Reducing Valves

PRH (36HLF) SERIES



HIGH FLOW DESIGN FOR LARGE COMMERCIAL APPLICATIONS

The Apollo® 36HLF reduces wasteful elevated supply pressures to a lower manageable pressure. Available with threaded or flange connections and optional rugged Y strainer.

FEATURES

- Approved to ASSE and CSA standards; listed with IAPMO
- Large yoke-type design aids flow and reduces pressure loss
- Initial pressure up to 400 psig
- Maximum temperature 180°F
- Integral by-pass relief protects against thermal expansion
- Bronze body & cage, stainless steel replaceable seat
- Sizes: 1/2", 3/4", 1", 1-1/4", 1-1/2", 2", & 3" NPT - threads (inlet and outlet): 2-1/2" & 3" also offered in 150 lb. flange
- Bottom access for easy inline repair
- Sealed cage is standard
- Stainless steel bolts, adjustment screws and spring
- NSF/ANSI 372 Lead Free
- Standard materials available as 36H option
- **Made in USA**

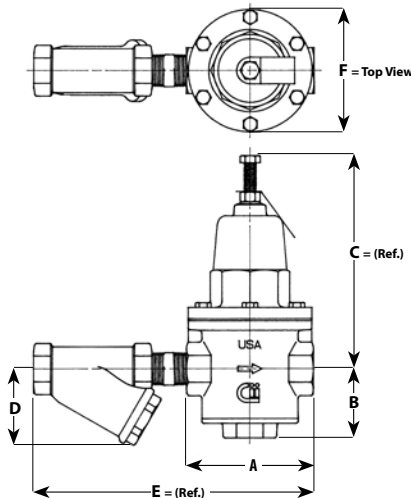

Size (in.)	A (in.)	B (in.)	C (in.)	D (in.)	E (in.)	F (in.)	Wt. w Strainer (lbs.)	Wt. w/o Strainer (lbs.)
NPT								
1/2"	4.13	2.25	7.00	1.88	8.38	4.00	7.0	6.00
3/4"	4.13	2.25	7.00	2.44	9.00	4.00	8.0	6.00
1"	4.81	2.31	7.50	4.00	10.25	4.69	12.0	8.00
1-1/4"	6.75	3.81	10.00	3.38	12.50	6.50	29.0	24.00
1-1/2"	6.75	3.19	10.00	3.88	13.13	6.50	29.0	23.00
2"	8.13	3.50	12.50	4.63	16.00	7.63	47.0	38.00
2-1/2"	8.13	3.50	12.50	5.94	16.69	7.63	49.0	37.00
3"	10.38	3.94	15.13	6.94	20.50	9.75	87.0	70.00
Flanged								
2-1/2"	10.38	3.50	12.50	7.13	21.69	7.63	105.0	55.00
3"	12.50	3.94	15.13	8.13	24.50	9.75	136.0	92.00

PART NUMBER MATRIX

36H			
36HLF - X	X	X	- OX
END CONNECTIONS	OPTIONS	SIZE	PRESSURE RANGE
2 - FNPT x FNPT (Standard)	0 - Standard	3 - 1/2"	01 - 25-75 psig (Standard)
7 - Flanged (2-1/2" - 3" only)	1 - With Y-Strainer	4 - 3/4"	02 - 10-35 psig
		5 - 1"	03 - 75-125 psig**
		6 - 1-1/4"	
		7 - 1-1/2"	
		8 - 2"	
		9 - 2-1/2"	
		0 - 3"	** Can be adjusted to 75-165 psig



See Water Pressure Reducing Valves Catalog (PHBRWPRV) for more detailed information about the products in this section.

Customer Service (704) 841-6000

COMMERCIAL PRODUCTS CATALOG

Water Pressure Reducing Valves

A127 SERIES



LARGE COMMERCIAL AND INDUSTRIAL APPLICATIONS

Apollo pilot control valves are ideal for a wide range of commercial and industrial applications, wherever the supply pressure needs to be reduced to a lower constant pressure.

Hydraulically operated diaphragm main valve automatically controls non-corrosive, non-abrasive fluids by means of a wide range of pilots.

FEATURES

- Ductile Iron Body & Bonnet, ASTM A536 Grade 65-45-12
- NSF Epoxy coated
- Bronze / stainless steel internals
- EPDM elastomers 40°F - 180°F
- Lead Free components used throughout
- Lead Free wye strainer protects pilot system from debris
- Isolation ball valves simplify maintenance and trouble shooting
- Each valve is 100% factory tested and can be pre-set to your requirements
- Wide range of control pilots and functions
- Opening speed control is standard
- Automatically reduces a higher up stream pressure to a constant lower downstream pressure
- Constant outlet pressure regardless of variations in upstream pressure or flow
- NSF/ANSI 372 Lead Free
- Pilot operated main valve is not subject to pressure fall-off
- Outlet pressure is adjustable with a single screw
- Optional low-flow bypass, Model A127-LF when wide extremes in flow demand are anticipated

MATERIAL OPTIONS

- Carbon Steel
- Stainless Steel
- Bronze
- Aluminum
- Nickel aluminum bronze
- Viton and Buna-N elastomers
- Stainless steel pilots and tubing
- Stainless steel internals

OTHER CONTROL FUNCTIONS

Valve Sizes	
Globe Flanged	1 1/4" - 24"
Angle Flanged	1 1/4" - 16"
Globe / Angle Threaded	1 1/4" - 3"
Globe / Angle Grooved	1 1/2" - 4"
Service Ratings - Ductile Iron	
150# Flanged	250 psi MAWP
300# Flanged	640 psi MAWP
Threaded	640 psi MAWP
Grooved	300 psi MAWP

A94	Diaphragm Check Valve
A108-2	Pressure Relief/Pressure Sustaining
A110	Differential Control
A115-2	Solenoid Control
A115-4	Solenoid Control/high capacity pilot
A120	Rate of Flow Control
A127LF/727LF	Low flow bypass
A800	Float Controlled On/Off Service
A810	Float Controlled, Modulating
A22 / A88	Digital Electronic Control, regulates pressure, flow or level

WATER PRESSURE REDUCING VALVES

Water Pressure Reducing Valves

A127 SERIES (CONT.)

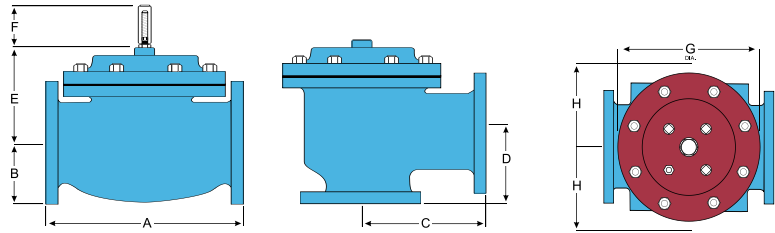

Size (in.)	End Connections A				End Connections C				End Connections D				E	H
	Screwed	Grooved	150# FLGD	300# FLGD	Screwed	Grooved	150# FLGD	300# FLGD	Screwed	Grooved	150# FLGD	300# FLGD		
1-1/4 - 1-1/2	8-3/4	8-3/4	8-1/2	8-3/4	4-3/8	4-3/8*	4-1/4	4-3/8	3-1/8	3-1/8*	3	3-1/8	6	10
2	9-7/8	9-7/8	9-3/8	9-7/8	4-3/4	4-3/4	4-3/4	5	3-7/8	3-7/8	3-7/8	4-1/8	6	11
2-1/2	10-1/2	10-1/2	10-1/2	11-1/8	6	6	6	6-3/8	4	4	4	4-3/8	7	11
3	13	13	12	12-3/4	6-1/2	6-1/2	6	6-3/8	4-1/2	4-1/2	4	4-3/8	6 1/2	11
4	—	15 1/4	15	15-5/8	—	7-5/8	7-1/2	7-13/16	—	5-5/8	5-1/2	5-13/16	8	12
6	—	—	17-3/4	18-5/8	—	—	10	10-1/2	—	—	6	6-1/2	10	13
8	—	—	25-3/8	26-3/8	—	—	12-11/16	13-3/16	—	—	8	8-1/2	11 7/8	14
10	—	—	29-3/4	31-1/8	—	—	14-7/8	15-9/16	—	—	11-3/8	12-1/16	15 3/8	17
12	—	—	34	35-1/2	—	—	17	17-3/4	—	—	11	11-3/4	17	18
14	—	—	39	40-1/2	—	—	—	—	—	—	—	—	18	20
16	—	—	40-3/8	42	—	—	20-13/16	21-5/8	—	—	15-11/16	16-1/2	19	20
24	—	—	62	63-3/4	—	—	—	—	—	—	—	—	27	28-1/2

*Grooved End Not Available in 1-1/4"

For further information request catalog ACVBR9000

Water Pressure Reducing Valves Accessories

W-8078-00 SERIES

PRESSURE GAUGES

These pressure gauges include a high pressure memory indicator that is used for testing water pressure. Temp. range: 50°F to 130°F.



W-8078-00

Model Number	LF Model Number	Connection	Pressure Range	Net Wt. (lbs.)
W-8078-00	—	3/4" hose thread	0-300 psig	.46
W-7793-00	W-2799-00	1/4" NPT	0-160 psig	.70



W-7793-00



W-2799-00

COMMERCIAL PRODUCTS CATALOG



BACKFLOW PREVENTERS

BACKFLOW PREVENTERS



See Backflow Prevention Catalog (BFCA9000) for more detailed information about the products in this section.

BACKFLOW PREVENTERS

Selection Guide

TYPE OF DEVICE	SERIES	**Apollo Recommended		APPLICATION		
		BACK SIPHONAGE	BACK PRESSURE	CONTINUOUS PRESSURE	AESTHETIC HAZARD	HEALTH HAZARD
DOUBLE CHECK VALVE	DCLF 4A DCLF 4An DC 45G	✓	✓	✓	✓	
DOUBLE CHECK DETECTOR ASSEMBLY	DCDALF 4A DCDALF 4An DCDA 45G	✓	✓	✓	✓	
REDUCED PRESSURE PRINCIPLE	RPLF 4A	✓	✓	✓	✓	✓
REDUCED PRESSURE PRINCIPLE (n & V Flow)	RPLF 4An	✓	✓	✓	✓	✓
REDUCED PRESSURE PRINCIPLE (Stainless Steel)	RP 40-S	✓	✓	✓	✓	✓
REDUCED PRESSURE DETECTOR ASSEMBLY	RPDALF 4A RPDALF 4An	✓	✓	✓	✓	✓
ATMOSPHERIC VACUUM BREAKER	AVB1, AVB1LF AVB2	✓			✓	✓
PRESSURE VACUUM BREAKER	PVB 4A, PVBLF 4A	✓		✓	✓	✓
SPILL RESISTANT PRESSURE VACUUM BREAKER	SVB 4W, SVBLF 4W	✓		✓	✓	✓
DUAL CHECK	DUC 4N, DUCLF 4N DUC 4FP DUC40, DUCLF40	✓	✓	✓	✓	
DUAL CHECK W/ ATMOS. PORT	DCAP, DCAPLF	✓	✓	✓	✓	
CARBONATED BEVERAGE BACKFLOW PREVENTER	CBBP	✓	✓	✓	✓	
HOSE CONNECTION VACUUM BREAKER	HBV2, HBV2LF	✓	✓*		✓	✓
ANTI FREEZE HOSE CONN. VACUUM BREAKER	HBVAF2, HBVAF2LF	✓	✓*		✓	✓
HOSE CONNECTION BACKFLOW PREVENTER	HBDUC, HBDUCLF	✓	✓*		✓	✓
LAB FAUCET VACUUM BREAKER	LFDUCLF	✓	✓		✓	

* Limited back pressure to 10' head

** Check with local authorities having jurisdiction

Double Check Valve Backflow Preventers

DC-4A SERIES



Sizes 1/2", 3/4", 1", 1-1/4", 1-1/2", 2"

TOP ENTRY DOUBLE CHECK VALVE ASSEMBLY

The Apollo MODEL DC 4A Double Check Valves are designed to prevent contamination of the potable water supply due to back-siphonage or backpressure from substances that are objectionable, but non-health hazards. The modular check valve captured spring cartridges have replaceable seats and reversible silicone seat discs. Ball valve shut-offs with stainless steel handles and nuts are standard.

FEATURES

- Low pressure loss
- Captured spring cartridge check valves
- Compact yet easy to maintain
- Shut-off ball valves w/ SS handles & nuts standard
- Top access for fast testing and maintenance
- Threaded testcock protectors
- Corrosion resistant
- No special tools required
- 5 year, domestic warranty
- **Lead-Free** option (DCLF 4A)
- Available with factory installed APOLLOXPRESS press connections
- UL, ULC Classified
- ASSE 1015
- IAPMO
- Approved by the Foundation for Cross-Connection Control and Hydraulic Research at the University of Southern California
- CSA
- Chloramine-resistant elastomers
- Patent pending
- Horizontal and vertical up approvals
- Maximum working pressure 175 psi
- Temperature range 33°F - 180°F
- Designed, manufactured, assembled and tested in South Carolina, USA



See Backflow Prevention Catalog (BFCA9000) for more detailed information about the products in this section.

Customer Service (704) 841-6000

COMMERCIAL PRODUCTS CATALOG

Double Check Valve Assemblies

DCLF 4A AND DCLF 4An SERIES



DCLF 4A Series
Sizes 2-1/2"-12"

DCLF 4An Series
Sizes 2-1/2"-12"



Optional Valve Setter



TriForce™ Check

DOUBLE CHECK VALVE ASSEMBLIES

The Apollo® DCLF 4A and DCLF 4An Double Check Valves are designed to prevent contamination of the potable water supply due to back-siphonage or backpressure from substances that are objectionable, but non-health hazards. The TriForce™ center stem guided check valves feature replaceable and reversible silicone seat discs. The body is stainless steel from 2-1/2"-8" and FDA epoxy coated ductile iron in the 10" and 12". Available with a wide variety of shutoff valve options. The DCLF 4An normally vertical up/vertical down oriented body incorporates an internal swivel connection providing the ability to pivot the second check.

FEATURES

- Stainless steel body: 2-1/2"-8"
- FDA epoxy coated ductile iron body: 10" & 12"
- Easy maintenance - no special tools required
- Low pressure loss as documented by an independent laboratory
- **Lead-Free**
- Chloramine-resistant elastomers
- ASSE 1015
- Approved by the Foundation for Cross-Connection Control and Hydraulic Research at the University of Southern California (DCLF 4A: 2-1/2" - 8") (DCLF 4AN: 2-1/2" - 8")
- UL, ULC Classified
- FM approved
- Maximum working pressure 175 psi
- Temperature range 33°F - 140°F, 180°F intermittent
- US Patent Nos. 6,443,184; 7,025,085; 7,533,699
- Made in the USA
- 5 year, domestic warranty
- 4A- Approved for horizontal and vertical up flow*
- 4An - Small installation space required - small footprint

* Contact factory for approval details

DC 4SG SERIES



DC 4SG Series
Sizes 2-1/2", 3", 4", 6"

DOUBLE CHECK VALVE ASSEMBLY

The Apollo® DC 4SG Series Double Check Valve is designed to prevent contamination of the potable water supply due to back-siphonage or backpressure from substances that are non-health hazards. The modular check valves have replaceable seats and reversible EPDM seat discs. Grooved connections on an epoxy-coated ductile iron body allow for easy connection to butterfly valves or gate valves.

FEATURES

- Short lay length
- Low pressure loss
- Modular check valves
- Reversible/replaceable seat discs
- Approved for vertical (up) and horizontal installations
- Gate valves epoxy coated (FDA)
- Corrosion resistant epoxy-coated ductile iron body
- ASSE 1015
- CSA
- Approved by the Foundation for Cross-Connection Control and Hydraulic Research at the University of Southern California
- AWWA C-510
- UL Classified
- FM approved
- US Patents #5,711,341 and #6,343,618

BACKFLOW PREVENTERS

Double Check Detector Assemblies

DCDALF 4A AND DCDALF 4An SERIES



DCDALF 4A Series
Sizes 2-1/2"-12"



DCDALF 4An Series
Sizes 2-1/2"-12"



Optional Valve Setter



TriForce™ Check

DOUBLE CHECK DETECTOR ASSEMBLY

The Apollo® DCDALF 4A and DCDALF 4An Double Check Detector Assemblies are designed to prevent contamination of the potable water supply due to back-siphonage or backpressure from substances that are objectionable, but non-health hazards. The TriForce™ center stem guided check valves feature replaceable and reversible silicone seat discs. The by-pass assembly serves to accurately measure water use of up to 2 GPM. Available in a wide variety of shut-off options. The DCDALF 4An normally vertical up/vertical down oriented body incorporates an internal swivel connection providing the ability to pivot the second check. The grooved connections on the bodies from 2-1/2" to 10" allow for easy connection to butterfly or gate shut-off valves. The 12" DCDALF 4An has flanged connections for gate shut-off valves.

FEATURES

- Stainless steel body: 2-1/2"-8"
- FDA epoxy coated ductile iron body: 10" & 12"
- Easy maintenance - no special tools required
- Low pressure loss as documented by an independent laboratory
- **Lead-Free**
- Chloramine-resistant elastomers
- ASSE 1048
- Approved by the Foundation for Cross-Connection Control and Hydraulic Research at the University of Southern California (DCDALF 4A: 2-1/2" - 8") (DCDALF 4AN: 2-1/2" - 8")
- UL, ULC Classified
- FM approved
- DCDA 4A - CSA 864.5 (6" Type 1)
- Maximum working pressure 175 psi
- Temperature range 33°F - 140°F, 180°F intermittent
- US Patent Nos. 6,443,184; 7,025,085; 7,533,699
- Made in the USA
- 5 year, domestic warranty
- Optional mounting of bypass on either side for ease of installation
- DCDALF 4An - Small installation space required - small footprint
- DCDALF 4An - Optional valve setters eliminate need for thrust blocks below grade

DCDA 4SG SERIES



DCDA 4SG Series
Sizes 2-1/2", 3", 4", 6", 8", 10"

DCDA 4SG SERIES DOUBLE CHECK DETECTOR ASSEMBLY

The Apollo® DCDA 4SG Series Double Check Detector Assembly is designed to prevent contamination of the potable water supply due to back-siphonage or backpressure from substances that are non-health hazards. The device consists of a mainline double check valve with resilient seated shut-off valves. The by-pass serves to accurately measure water use of up to 3 gpm. Grooved connections on an epoxy-coated ductile iron body allow for easy connection to butterfly valves or gate valves.

FEATURES

- Short lay length
- Low pressure loss
- Reversible/replaceable seat discs
- Approved for vertical and horizontal installations
- **Lead-Free** (2-1/2" - 6" only)
- Gate valves epoxy coated (FDA)
- Corrosion resistant FDA epoxy-coated ductile iron body
- UL Classified
- FM approved
- Approved by the Foundation for Cross-Connection Control and Hydraulic Research at the University of Southern California (Non-Lead Free)
- ASSE 1048
- CSA
- US Patents #5,711,341 and #6,343,618

COMMERCIAL PRODUCTS CATALOG

Reduced Pressure Backflow Preventers

RP 4A SERIES



RPLF 4A Series (shown)
Sizes 1/2", 3/4", 1", 1-1/4", 1-1/2", 2"

REDUCED PRESSURE PRINCIPLE

The Apollo Series RP 4A Reduced Pressure Principle Backflow Preventer is designed to give maximum protection against backflow caused by either back-pressure or back-siphonage from substances that are hazardous. The durable but economical device is easily maintained in the line with modular check cartridge assemblies that require no special tools. It consists of two independently acting spring-loaded check valves with an automatic differential relief valve located between the check valves. All testcocks are mounted at the top of the unit to assure easy access during repair and maintenance when unit is installed in tight places.

FEATURES

- Maximum protection against back-pressure/back-siphonage
- Modular check valve cartridges w/easily replaced parts
- Reversible/removable chloramine-resistant silicone seat discs
- Low head pressure loss
- Top mounted test cocks
- Threaded testcock protectors
- Internal sensing passage
- ASSE 1013
- CSA B64.4
- **Lead-Free** option (RPLF 4A)
- Available with factory installed APOLLOXPRESS press connections
- UL Classified (less shut-offs)
- Approved by the Foundation for Cross-Connection Control and Hydraulic Research at the University of Southern California
- Standard with full port ball valves with stainless steel handles
- Corrosion resistant
- Maximum working pressure 175 psig
- Operating temperature range 33°F-180°F
- Horizontal installation approvals on 1/2" through 2"
- Designed, manufactured, assembled and tested in South Carolina, USA
- 5 year, domestic warranty

RP 40S SERIES



RP 40S Series
Sizes 1/4", 3/8", 1/2", 3/4", 1"

STAINLESS STEEL REDUCED PRESSURE PRINCIPLE BACKFLOW PREVENTER

The Apollo Series RP 40S Stainless Steel Reduced Pressure Principle Backflow Preventer is designed to give maximum protection against backflow caused by either backpressure or back-siphonage from a cross-connection wherein a contaminant hazard exists (i.e. a health hazard), or a pollutant hazard exists (i.e. a non-hazard). The assembly is composed of two spring-loaded poppet type check valves and a mechanically independent, hydraulically dependent pressure differential relief valve set in an integral stainless steel body. Three of the testcocks are mounted at the top to assure easy access during repair and maintenance when unit is installed in tight places.

FEATURES

- Stainless steel body and covers
- Easy to install and repair
- Internal sensing passage
- Low head loss
- Reversible/Removable seat discs
- Replaceable seats
- Comes standard with Apollo® stainless steel full port ball valves with stainless steel handles
- **Lead-Free** (Standard)
- Maximum working pressure 175 psig
- Temperature range 33°F-180°F
- Approved by the Foundation for Cross-Connection Control and Hydraulic Research at the University of Southern California
- ASSE 1013
- CSA
- Designed, manufactured, assembled and tested in South Carolina, USA
- 5 year, domestic warranty

BACKFLOW PREVENTERS

Reduced Pressure Backflow Preventers

RPLF 4A AND RPLF 4An SERIES

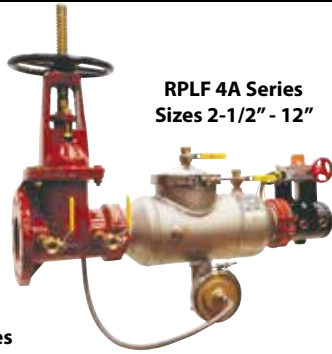

RPLF 4A Series
Sizes 2-1/2" - 12"

RPLF 4An Series
n Flow



RPLF 4An Series
Vertical Up Flow



Optional Valve Setter



TriForce™ Check

REDUCED PRESSURE PRINCIPLE BACKFLOW PREVENTERS

The Apollo® RPLF 4A and RPLF 4An Reduced Pressure Principle Backflow Preventers consist of two independently acting, TriForce™ center stem guided check valves with a differential pressure relief valve located between the check valves. These units are designed to give maximum protection against backflow of health or non-health hazard fluids by either back-pressure or back-siphonage. The durable stainless steel units (2-1/2"-8") and the FDA epoxy coated ductile iron units (10" and 12") are easily maintained in the line without any special tools. The TriForce™ check valves operate with a spring assist in the flowing condition to provide excellent flow rates which are documented by an independent laboratory. The RPLF 4An normally vertical up/vertical down oriented body incorporates an internal swivel connection providing the ability to pivot the second check 180° to a vertical up/vertical up flow.

FEATURES

- Stainless steel body: 2-1/2"-8"
- FDA epoxy coated ductile iron body: 10" & 12"
- Easy maintenance - no special tools required
- Low pressure loss as documented by an independent laboratory
- RPLF 4A - Approved for horizontal flow
- RPLF 4An - Small installation space required - small footprint
- Chloramine-resistant elastomers
- **Lead-Free** (RPLF 4A, RPLF 4AN)
- ASSE 1013
- Approved by the Foundation for Cross-Connection Control and Hydraulic Research at the University of Southern California (RPLF 4A 2-1/2" - 6", RPLF 4AN 4" - 6")
- UL, ULC Classified
- FM approved
- Maximum working pressure 175 psi
- Temperature range 33°F - 140°F, 180°F intermittent
- US Patent Nos. 6,443,184; 7,025,085; 7,533,699
- Made in the USA
- Optional Air Gap Drains
- Optional valve setters eliminate need for thrust blocks between elbows
- 5 year, domestic warranty

COMMERCIAL PRODUCTS CATALOG

Reduced Pressure Detector Assemblies

RPDALF 4A AND RPDALF 4An SERIES



RPDALF 4A Series
Type 2 Bypass
(Standard)

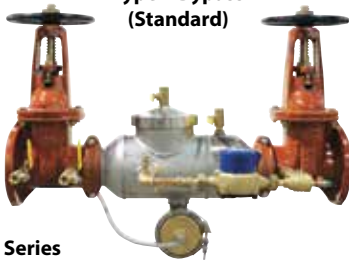

RPDALF 4An Series



RPDALF 4An Series
Sizes 2-1/2"-12"



Optional Valve Setter



TriForce™ Check

REDUCED PRESSURE DETECTOR ASSEMBLIES

The Apollo® RPDALF 4A and RPDALF 4An Reduced Pressure Detector Assemblies consists of two independently acting, TriForce™ center stem guided check valves with a differential pressure relief valve located between the check valves. These units are designed to give maximum protection against backflow of health or non-health hazard fluids by either back-pressure or back-siphonage and at the same time detect leakage or unauthorized use of water from fire or automatic sprinkler systems. The durable stainless steel units (2-1/2" to 8") and the FDA epoxy coated ductile iron units (10" and 12") are easily maintained in line without any special tools. The TriForce™ check valves operate with a spring assist in the flowing condition to provide low flow rates which are documented by an independent laboratory. The RPDALF 4An normally vertical up/vertical down oriented body incorporates an internal swivel connection providing the ability to pivot the second check 180° to a vertical up/vertical up flow.

FEATURES

- Stainless steel body: 2-1/2"-8"
- FDA epoxy coated ductile iron body: 10" & 12"
- Easy maintenance - no special tools required
- Low pressure loss as documented by an independent laboratory
- ASSE 1047
- Approved by the Foundation for Cross-Connection Control and Hydraulic Research at the University of Southern California (RPDALF 4A 2-1/2" - 6", RPDALF 4AN 4")
- RPDALF 4An - Small installation space required - small footprint
- **Lead-Free** (RPDALF 4A)
- UL, ULC Classified
- FM approved
- Maximum working pressure 175 psi
- Temperature range 33°F - 140°F, 180°F intermittent
- Optional air gap drains
- US Patent Nos. 6,443,184; 7,025,085; 7,533,699
- Made in the USA
- 5 year, domestic warranty
- Optional mounting of bypass on either side for ease of installation

BACKFLOW PREVENTERS

Pressure Vacuum Breaker Backflow Preventers

PVB 4A SERIES



Sizes 1/2", 3/4", 1", 1-1/4", 1-1/2", 2"

4A FREEZE RESISTANT PRESSURE VACUUM BREAKER

The Apollo Model PVB 4A Pressure Vacuum Breakers are designed to prevent contamination of potable water due to back-siphonage. An integral relief valve serves to reduce the possibility of damage due to intermittent freezing conditions. The modular check valve cartridge has a replaceable seat and a reversible silicone seat disc. Shut-off ball valves with stainless steel handles and nuts are standard.

FEATURES

- Modular cartridge check valve
- Low pressure loss
- Built-in freeze resistant relief valve
- Compact yet easy to maintain
- Shut-off ball valves w/SS handles & nuts standard
- Test cocks located for easy draining
- Threaded testcock protectors
- Corrosion resistant
- 5 year, domestic warranty
- No special tools required
- Unique canopy detachment
- Patent pending
- **Lead Free** option (3/4" & 1" only)
- ASSE 1020
- Approved by the Foundation for Cross-Connection Control and Hydraulic Research at the University of Southern California
- Easy maintenance
- Maximum operating pressure 150 psi
- Design pressure 300 psi
- Temperature range 33°F - 140°F
- **MADE IN THE USA**

COMMERCIAL PRODUCTS CATALOG

Vacuum Breaker Backflow Preventers

AVB1/AVB2 SERIES



AVB1
Sizes 1/4", 3/8", 1/2", 3/4",
1", 1-1/4", 1-1/2", 2"



AVB2
Sizes 1/4", 3/8", 1/2",
3/4"
(Optional Polished
Chrome Finish
Shown)

ATMOSPHERIC TYPE VACUUM BREAKERS

The Apollo Series Atmospheric Type Vacuum Breakers are designed to prevent back-siphonage of polluted water into a potable water system. They should only be installed in areas where spillage of water could not cause damage and where it can be accessible for periodic maintenance. These devices are not designed for continuous pressure application. Should be installed a minimum of 6" above all downstream piping with no downstream shutoffs.

FEATURES

- Corrosion resistant
- Bronze body (AVB1)
- Forged Body (AVB2)
- Suitable for hot or cold water service: (up to 212°F at 125 psig) for up to 1" (up to 180°F at 125 psig) for 1-1/4" thru 2"
- **Lead-Free** option on AVB1/38-100 Series
- Heat resistant silicone seat disc
- Rough brass, rough chrome, or polished chrome finish
- Easy to maintain
- Compact and lightweight
- Durable
- ASSE1001

Spill Resistant Vacuum Breaker Backflow Preventers

SVB 4W SERIES



Sizes 1/4", 3/8", 1/2"

SPILL RESISTANT VACUUM BREAKERS

The Apollo Series SVB 4W Spill Resistant Vacuum Breaker is designed to prevent contamination of the potable water supply due to back-siphonage. The SVB is ideally suited for continuous pressure, indoor applications where water spillage is undesirable. The device has a straight through flow path for minimal head loss. All components are easily accessible for easy repair and maintenance. All components are made of corrosion resistant materials for years of reliable service. Should be installed 6" above all downstream piping.

FEATURES

- Corrosion Resistant
- In-Line Flow
- Integral Shut-Off Valves w/ Stainless Steel Handles and Nuts
- Threaded testcock protectors
- Designed For Easy Maintenance
- **Lead-Free** option
- Economical
- Low Head Loss
- Maximum Working Pressure 150 psig
- Operating Temperature Range 33°F-180°F
- ASSE 1056
- 5 year, domestic warranty
- Approved by the Foundation for Cross-Connection Control and Hydraulic Research at the University of Southern California

BACKFLOW PREVENTERS

Dual Check Backflow Preventers

DUCLF-4N SERIES



Dimensions (In.) – Weight (Lbs.)

DUAL CHECK VALVE

The Apollo DUCLF-4N Series Dual Check Valve Backflow Preventer is designed to prevent cross-connections of non-potable water (non-hazardous) into safe drinking water systems. It is a compact and economical device that consists of two independently-acting, spring-loaded check valves in a corrosion-resistant material.

FEATURES

- Low Head Loss
- Independently-acting Check Valves
- Compact and Lightweight
- Corrosion Resistant
- Replaceable Check Modules
- Industry Lay Lengths
- Available in Standard and Swivel Types
- Maximum Working Pressure 175 psi
- Operating Temperature Range 33°F-180°F
- ASSE1024
- CSA B64.6
- 5 year, domestic warranty

Dual Check Backflow Preventers

DUC 4FP SERIES



FIRE PROTECTION DUAL CHECK VALVE

The Apollo DUC 4FP Series Dual Check Backflow Preventer for Residential Fire Sprinkler Systems prevents backflow by either backpressure or backsiphonage from a cross-connection between potable water lines and substances that are objectionable, but not health-hazards.

FEATURES

- Low Pressure Loss
- Corrosion Resistant
- Replaceable Check Modules
- Pressure drop at 30 gpm is less than 6 psi
- Complies with NFPA Standard 13D
- 5 year, domestic warranty
- Maximum Supply Pressure 175 psi
- Temperature Range 33°F - 180°F
- ASSE 1024
- UL Classified
- CSA B64.6
- **Made in the USA**

COMMERCIAL PRODUCTS CATALOG

Carbonated Beverage Backflow Preventers

CBBP SERIES



Sizes 1/4", 3/8"

CARBONATED BEVERAGE BACKFLOW PREVENTER

The Apollo CBBP Series Carbonated Beverage Backflow Preventer (CBBP) is designed to prevent the contamination of the potable water supply due to backflow when installed on water distribution lines serving beverage dispensing equipment. The device consists of two independently acting check valves biased to a normally closed position. A normally open atmospheric port is located between the check valves. During backflow conditions, the port vents gases and/or liquids. Additionally, the CBBP is equipped with a 100 mesh integral strainer screen at the inlet. All wetted areas of the device are non-toxic, corrosion resistant, and approved for use with potable water. The CBBP is suitable for supply pressures to 150 psig and water temperatures from 33° to 130° F.

FEATURES

- Compact Design
- Lowest head loss
- Atmospheric vent provides indication of problems
- Integral strainer for equipment protection
- **Lead Free** standard
- Available in SAE & NPT connections
- Repairable check assemblies
- Non-metallic body for corrosion resistance
- CSA Certified to ANSI/NSF-61
- ASSE1022
- 5 year, domestic warranty

Dual Check Backflow Preventers

DUC 40 SERIES



Sizes 1/2", 3/4", 1"

DUAL CHECK VALVE

The Apollo Series DUC 40 Dual Check Valve prevents backflow by either backpressure or back-siphonage resulting from a cross-connection between potable water lines and substances that are objectionable, but not health-hazards.

FEATURES

- In-line repairable
- Low pressure loss
- Corrosion resistant
- Compact and lightweight
- Independently-acting check valves
- ASSE 1024
- CSA B64.6
- Available in standard and swivel types
- **Lead-Free** option (DUCLF 40)
- **MADE IN THE USA**
- 5 year, domestic warranty

PERFORMANCE RATING

Maximum Operating Pressure 175 psi

Temperature Range 33° F - 180° F

APPROVALS

ASSE® 1024 and CSA® B64.6

BACKFLOW PREVENTERS

Dual Check w/Atmospheric Port Backflow Preventers

DCAP SERIES



Sizes 1/2", 3/4"

DUAL CHECK WITH ATMOSPHERIC PORT BACKFLOW PREVENTER

The Apollo DCAP Series Backflow Preventer is designed to protect residential and commercial water supply lines from back-siphonage or back-pressure of non-potable (non-hazardous) substances. It has an intermediate atmospheric vent to insure protection from backflow conditions. It consists of two independently acting and spring-loaded check valves in a corrosion resistant material.

FEATURES

- Corrosion resistant
- Low head loss
- Independently acting check valves
- Ease of repair and installation
- Economical
- Suitable for hot or cold water service
- Durable
- Maximum working pressure 175 psig
- ASSE 1012
- CSA
- Inlet temperature range 33°F-210°F
- 5 year, domestic warranty
- Maximum backflow temperature 250°F

Freeze Protection Valve

FPV SERIES



FREEZE PROTECTION VALVE

The Apollo Series FPV Freeze Protection Valve protects backflow preventers from freezing when installed in accordance with manufacturer's instructions. All internal parts of the Freeze Protection Valve are replaceable.

FEATURES

- Installs easily on all backflow preventers
- Ease of repair with available repair kit
- 175 psig maximum operating pressure
- Corrosion resistant
- 1/4" male pipe thread inlet port
- Available with 1/8" male x 1/4" female test cock
- Discharge port accommodates 5/8" I.D. hose
- **Lead-Free** option (FPVLF)
- Mechanical operating principle
- Nominal start to open temperature of 35°F
- Maximum temperature of 180°F
- Compact design
- Patented design
- IAPMO listed
- US patent #6,374,849
- 5 year, domestic warranty

COMMERCIAL PRODUCTS CATALOG

Hose Connection Vacuum Breakers Backflow Preventers

HBV2 SERIES



Optional Satin Chrome Finish (shown)
3/4"
Apollo International

3/4" HOSE CONNECTION VACUUM BREAKERS

Apollo's HBV Hose Connection Vacuum Breakers are designed to prevent cross-connection caused by back-siphonage. They consist of a single check valve with atmospheric vacuum breaker vent. They feature a break-away set-screw for tamper-proof protection. They are not suitable for continuous pressure applications.

FEATURES

- Maximum Working Pressure 125 psig
- Maximum Temperature 180°F.
- ASSE1011
- CSA B64.2

HBVAF2 SERIES



3/4"
Apollo International

3/4" FREEZE RESISTANT HOSE CONNECTION VACUUM BREAKERS

The Apollo Series HBVB Freeze Resistant Hose Connection Vacuum Breaker is especially designed to prevent back-siphonage on wall and yard hydrants. It features a break-away set-screw for tamper-proof protection and automatic drain for protection against freezing conditions when hose is removed. It is not suitable for continuous pressure applications.

FEATURES

- Maximum Working Pressure 125 psig
- Maximum Temperature 180°F.
- ASSE1011

Hose Connection Dual Check /Lab Faucet Dual Check Backflow Preventers

HBDUC SERIES



38-304-02
Size 3/4"

3/4" HOSE CONNECTION DUAL CHECK

The Apollo Series HBDUC is designed to provide an in-line testable hose connection that will prevent backflow due to back-siphonage or low head back-pressure. Each device consists of two independent checks, forced loaded in the closed position with an atmospheric vent between the checks. The device is threaded for hose connection at both the inlet and outlet with a break-away set screw on the inlet for tamper proof installations. These devices are not suitable for continuous pressure applications.

FEATURES

- Corrosion resistant body and checks
- Low Head loss
- Easy to install with break-away set screw
- Protects against back siphonage and low-head back pressure
- ASSE1052

LFDUC SERIES



Sizes 1/4", 3/8"

LABORATORY FAUCET DUAL CHECK BACKFLOW PREVENTER

The Apollo Series LFDUC is designed to provide protection against back-siphonage wherever a hose is connected to a faucet. The device consists of two independently acting checks with an intermediate relief port or vent. It is suitable for supply pressure up to 150 psig and a temperature range of 33°F-212°F. Not suitable for constant pressure conditions.

FEATURES

- Corrosion resistant
- Forged brass body
- Suitable for hot or cold water service up to 212°F and 125 psi
- Easy to maintain
- Polished (-CP2 and -CP3 are rough brass only)
- Compact and lightweight
- ASSE 1035

BACKFLOW PREVENTERS

Accessories – Backflow Preventers

DIFFERENTIAL PRESSURE GAUGE TEST KITS



The Apollo Backflow Preventer Test Kits are compact, lightweight and portable testing devices. They come equipped with a gauge, hoses (with integral filters) and all required adapter fittings. Also included is a flexible or adjustable strap for hanging the gauge, laminated test procedures and a molded plastic carrying case with foam inserts.

TK3

These are three-valve test kits used for testing all DCV, RPZ, PVB & SVB backflow preventers.

- Differential pressure type with a dual scale of 0-15 psid/0-100kPa differential pressure range with a ± 0.2 psig (Descending) accuracy. Maximum working pressure 200 psig.

TK5

This is a five-valve test kit used for testing all DCV, RPZ, PVB & SVB backflow preventers. The five valve test kit is similar to the three valve kit except it has two additional valves that make it possible to bleed lines without disconnecting hoses.

Factory No.	Model No.	Application	Wt./Ea
40-200-TKU	TK3	ALL DCV, RPZ, PVB & SVB	6.5
40-200-TKSU	TK5	ALL DCV, RPZ, PVB & SVB	6.5

TFK SERIES TEST KIT FITTING



Brass fitting which installs onto Backflow Preventer Test Cocks by hand. No tools required. No Teflon® tape to deal with. Provides quicker testing. Sets of three fittings with o-rings for 1/4" SAE connections to the test kits. Packaged in a reclosable plastic bag.

Size	Factory No.	Model No.	Backflow Application
1/4" SAE x 1/4" NPT	40-000-TFK	TFK14	1/4" - 2"
1/4" SAE x 1/2" NPT	40-001-TFK	TFK12	2-1/2" - 6"
1/4" SAE x 3/4" NPT	40-002-TFK	TFK34	8" - 12"
Set of all 3 sizes	40-003-TFK	TFKSET	1/4" - 12"

HCPG SERIES PRESSURE GAUGE



3/4" HOSE CONNECTION PRESSURE GAUGE

The Apollo Hose Connection Pressure Gauge is designed to measure water pressure through a 3/4" hose thread connection. It consists of an indicator needle to determine maximum pressure.

Ordering No. - W807800 Model No. - HCPG

FEATURES

- 2-1/2" face dial
- 0 - 300 psig pressure range
- Swivel type 3/4" hose connection
- Adjustable indicator needle
- Temperature range = 50°F - 130°F
- Wt./Ea. 46 Lbs.

ST1 SERIES SIGHT TUBE



ST1 SERIES SIGHT TUBE

The kit allows for visual inspection during testing, provides an extension to the check valve body and offers quick connection with the 90° elbow. Provides means to static test double check backflow preventers.

Ordering No. - 40-200-ST Model No. - ST1

COMMERCIAL PRODUCTS CATALOG

Accessories – Backflow Preventers

40 200 BV BLEED VALVE



BLEED VALVE

Test valve used to provide accurate readings in field test of the Double Check Valve backflow preventers. Benefits include quick connections, quick bleed off of testing lines and useful in tight locations.

VALVE SETTERS



Apollo Valve 4An Setters are specifically designed to match the mounting dimensions of the 4An products. The three-piece configuration simplifies installation and eliminates the need for thrust blocks between the elbows. All hardware is stainless steel and the entire unit is FDA Epoxy coated inside and out. The mechanical joint connections are to AWWA C153 and the flanges are to ANSI B16.1 Class 125.

MODEL RP 40 & RP 4A BACKFLOW PREVENTERS



AIR GAP DRAIN

For installation with Conbraco's RP 40, RPDA 40, RP 4A, RPDA 4A, RP 4An, and RPDA 4An Series Reduced Pressure Principle backflow preventers.

The Apollo Air Gap Drain (AGD) is designed to funnel minor relief valve discharges, due to line pressure fluctuations and /or minor check valve fouling, into the drainage system. Drain piping is easily attached to the drain's threaded bottom.

Note: The AGD is designed to collect expected minor discharges due to fouled checks or pressure fluctuations but not the full discharge capacity of the relief valve.



GATE, GLOBE & CHECKS

GATE, GLOBE & CHECKS



*See Gate, Globe & Check Valves Catalog (GGC9000)
or Check Valve Catalog (PHBRCHV) for more detailed
information about the products in this section.*



GATE, GLOBE & CHECKS

Bronze Gate Valves – Made in USA



MODEL 101S



Meets MSS SP-80 standard
ASTM B62 bronze materials
MSS SP-139 lead free option (CWP only)

SOLDER END RISING STEM GATE VALVE

FEATURES

- Threaded Bonnet
- Solid Bronze Disc
- 200 CWP
- Max. Temp: 406°F
- **Lead Free** option (NSF 61/NSF 372)

Series Number	LF Series Number	NPS	Length (in.)	Height (in.)	Weight (lb.)
30-083-01	30LF-083-01	1/2	1.88	4.85	1.00
30-084-01	30LF-084-01	3/4	2.43	5.71	1.30
30-085-01	30LF-085-01	1	2.96	6.71	2.20
30-086-01	30LF-086-01	1 1/4	3.14	8.10	3.20
30-087-01	30LF-087-01	1 1/2	3.44	9.08	4.40
30-088-01	30LF-088-01	2	4.11	11.28	7.00
30-089-01	30LF-089-01	2 1/2	4.79	14.58	13.80
30-080-01	30LF-080-01	3	5.43	19.07	17.70

Length is measured from end to end. Height is measured from centerline to top of wheel in full open position.

MODEL 101T



Meets MSS SP-80 standard
ASTM B62 bronze materials
MSS SP-139 lead free option (CWP only)

CLASS 125 NPT END RISING STEM GATE VALVE

FEATURES

- Threaded Bonnet
- Solid Bronze Disc
- 200 CWP
- 125 SWP
- Max. Temp: 406°F
- **Lead Free** option (NSF 61/NSF 372)

Series Number	LF Series Number	NPS	Length (in.)	Height (in.)	Weight (lb.)
30-001-01	30LF-001-01	1/4	1.76	4.57	0.80
30-002-01	30LF-002-01	3/8	1.76	4.51	0.77
30-003-01	30LF-003-01	1/2	2.03	4.85	1.00
30-004-01	30LF-004-01	3/4	2.07	5.71	1.30
30-005-01	30LF-005-01	1	2.45	6.71	2.16
30-006-01	30LF-006-01	1 1/4	2.63	8.10	3.20
30-007-01	30LF-007-01	1 1/2	2.88	9.08	4.36
30-008-01	30LF-008-01	2	3.06	11.28	7.01
30-009-01	30LF-009-01	2 1/2	4.13	14.58	13.79
30-000-01	30LF-000-01	3	4.48	19.07	17.70

Length is measured from end to end. Height is measured from centerline to top of wheel in full open position.

MODEL 102S



Meets MSS SP-80 standard
ASTM B62 bronze materials
MSS SP-139 lead free option (CWP only)

SOLDER END NON RISING STEM GATE VALVE

FEATURES

- Threaded Bonnet
- Solid Bronze Disc
- 200 CWP
- Max. Temp: 406°F
- **Lead Free** option (NSF 61/NSF 372)

Series Number	LF Series Number	NPS	Length (in.)	Height (in.)	Weight (lb.)
30-043-01	30LF-043-01	1/2	1.88	3.56	0.85
30-044-01	30LF-044-01	3/4	2.43	4.05	1.19
30-045-01	30LF-045-01	1	2.96	4.55	1.98
30-046-01	30LF-046-01	1 1/4	3.14	5.14	2.80
30-047-01	30LF-047-01	1 1/2	3.44	6.02	3.95
30-048-01	30LF-048-01	2	4.11	7.09	5.88
30-049-01	30LF-049-01	2 1/2	4.79	9.11	12.19
30-040-01	30LF-040-01	3	5.43	12.61	16.84

Length is measured from end to end. Height is measured from centerline to top of wheel in full open position.



See Gate, Globe & Check Catalog (GGC9000) for more detailed information about the products in this section.

Customer Service (704) 841-6000

COMMERCIAL PRODUCTS CATALOG

Bronze Gate Valves – Made in USA



MODEL 102T



Meets MSS SP-80 standard
ASTM B62 bronze materials
MSS SP-139 lead free option (CWP only)

CLASS 125 NPT NON RISING STEM GATE VALVE

FEATURES

- Threaded Bonnet
- Solid Bronze Disc
- 200 CWP
- 125 SWP
- **Lead Free** option (NSF 61/NSF 372)

Series Number	LF Series Number	NPS	Length (in.)	Height (in.)	Weight (lb.)
30-031-01	30LF-031-01	1/4	1.76	3.29	0.74
30-032-01	30LF-032-01	3/8	1.76	3.29	0.71
30-033-01	30LF-033-01	1/2	2.03	3.56	0.85
30-034-01	30LF-034-01	3/4	2.07	4.05	1.19
30-035-01	30LF-035-01	1	2.45	4.55	1.98
30-036-01	30LF-036-01	1 1/4	2.63	5.14	2.80
30-037-01	30LF-037-01	1 1/2	2.88	6.02	3.95
30-038-01	30LF-038-01	2	3.06	7.09	5.88
30-039-01	30LF-039-01	2 1/2	4.13	9.11	12.19
30-030-01	30LF-030-01	3	4.48	12.61	16.84

Length is measured from end to end. Height is measured from centerline to top of wheel in full open position.

MODEL 102T-K



Meets MSS SP-80 standard
ASTM B62 bronze materials

CLASS 125 NPT NON RISING STEM IRRIGATION GATE VALVE

FEATURES

- Threaded Bonnet
- Solid Bronze Disc
- Bronze Cross-Handle (irrigation)
- 200 CWP
- 125 SWP
- SS Stem Nut

Series Number	NPS	Length (in.)	Height (in.)	Weight (lb.)
30-033-01K	1/2	2.03	3.56	0.85
30-034-01K	3/4	2.07	4.05	1.19
30-035-01K	1	2.45	4.55	1.98
30-036-01K	1 1/4	2.63	5.14	2.80
30-037-01K	1 1/2	2.88	6.02	3.95
30-038-01K	2	3.06	7.09	5.88
30-039-01K	2 1/2	4.13	9.11	12.19
30-030-01K	3	4.48	12.61	16.84

Length is measured from end to end. Height is measured from centerline to top of wheel in full open position.

MODEL 103T



Meets MSS SP-80 standard
ASTM B62 bronze materials

CLASS 125 NPT RISING STEM GATE VALVE

FEATURES

- Union Bonnet
- Solid Bronze Disc
- 200 CWP
- 125 SWP

Series Number	NPS	Length (in.)	Height (in.)	Weight (lb.)
30-051-01	1/4	1.76	4.57	0.90
30-052-01	3/8	1.76	4.51	0.86
30-053-01	1/2	2.03	4.85	1.07
30-054-01	3/4	2.07	5.71	1.43
30-055-01	1	2.45	6.71	2.44
30-056-01	1 1/4	2.63	8.10	3.71
30-057-01	1 1/2	2.88	9.08	4.89
30-058-01	2	3.06	11.28	7.53
30-059-01	2 1/2	4.96	14.58	15.33
30-050-01	3	4.48	19.07	19.56

Length is measured from end to end. Height is measured from centerline to top of wheel in full open position.

GATE, GLOBE & CHECKS

Bronze Gate Valves – Made in USA



MODEL 106T



Meets MSS SP-80 standard
ASTM B62 bronze materials

CLASS 150 NPT NON RISING STEM GATE VALVE

FEATURES

- Threaded Bonnet
- Solid Bronze Disc
- 300 CWP
- 150 SWP

Series Number	NPS	Length (in.)	Height (in.)	Weight (lb.)
30-281-01	1/4	1.76	3.29	0.74
30-282-01	3/8	1.76	3.29	0.71
30-283-01	1/2	2.03	3.56	0.98
30-284-01	3/4	2.07	4.05	1.21
30-285-01	1	2.45	4.55	1.98
30-286-01	1 1/4	2.63	5.14	2.80
30-287-01	1 1/2	2.88	6.02	4.06
30-288-01	2	3.06	7.09	5.88
30-289-01	2 1/2	4.13	9.11	12.19
30-280-01	3	4.48	12.61	16.90

Length is measured from end to end. Height is measured from centerline to top of wheel in full open position.

MODEL 107T



Meets MSS SP-80 standard
ASTM B62 bronze materials

CLASS 150 NPT RISING STEM GATE VALVE

FEATURES

- Union Bonnet
- Solid Bronze Disc
- 300 CWP
- 150 SWP

Series Number	NPS	Length (in.)	Height (in.)	Weight (lb.)
30-201-01	1/4	1.76	4.57	0.90
30-202-01	3/8	1.76	4.51	0.86
30-203-01	1/2	2.03	4.85	1.07
30-204-01	3/4	2.07	5.71	1.43
30-205-01	1	2.45	6.71	2.50
30-206-01	1 1/4	2.63	8.10	3.69
30-207-01	1 1/2	2.88	9.13	5.01
30-208-01	2	3.06	11.28	7.53
30-209-01	2 1/2	4.13	14.58	15.33
30-200-01	3	4.48	16.90	19.56

Length is measured from end to end. Height is measured from centerline to top of wheel in full open position.

MODEL 111T AND MODEL 116T



Model 116T Available December 2012
Meets MSS SP-80 standard
ASTM B61 bronze materials

CLASS 300 NPT RISING STEM GATE VALVE

FEATURES

- Union Bonnet
- Solid Bronze Disc
- Model 116T has Type 316 SS Seats
- 1000 CWP
- 300 SWP

Series Number	SS Seat Series Number	NPS	Length (in.)	Height (in.)	Weight (lb.)
30-443-01	30-453-01	1/2	2.31	4.97	1.40
30-444-01	30-454-01	3/4	2.56	6.22	2.30
30-445-01	30-455-01	1	2.89	6.94	3.50
30-446-01	30-456-01	1 1/4	3.01	8.29	5.10
30-447-01	30-457-01	1 1/2	3.05	9.28	6.80
30-448-01	30-458-01	2	3.08	11.37	9.60

Length is measured from end to end. Height is measured from centerline to top of wheel in full open position.



See Gate, Globe & Check Catalog (GGC9000) for more detailed information about the products in this section.

Customer Service (704) 841-6000

COMMERCIAL PRODUCTS CATALOG

Iron Gate Valves – Apollo International™

MODEL 610F



CLASS 125 FLANGED GATE VALVE

FEATURES

- Compatible with ANSI 125# & 150# Flanges
- Full Port
- Bronze Mounted Seat Rings
- Solid Wedge
- Adjustable Graphite Stem Packing
- Non-Rising Stem
- Bolted Bonnet
- Back Seat Protection
- Certified NSF/ANSI 372 Lead Free

STANDARDS

MSS SP-70

"Gray Iron Gate Valves Flanged and Threaded"

ASME B16.10

"Face-to-Face and End-to-End Dimensions of Valves"

Series Number	NPS	Length (in.)	Height (in.)	Weight (lb.)
6GA-108-B1	2	7.00	14.57	36.0
6GA-109-B1	2 1/2	7.50	16.34	48.0
6GA-100-B1	3	8.00	18.90	59.0
6GA-10A-B1	4	9.00	20.67	104
6GA-10B-B1	5	10.00	24.61	150
6GA-10C-B1	6	10.50	28.74	192
6GA-10E-B1	8	11.50	32.48	260
6GA-10G-B1	10	13.00	37.40	434
6GA-10H-B1	12	14.00	43.31	606
6GA-10J-B1	14	15.00	37.01	926
6GA-10K-B1	16	16.00	42.52	1098
6GA-10M-B1	18	17.00	46.46	1543
6GA-10N-B1	20	18.00	54.33	1638
6GA-10P-B1	24	20.00	57.48	2756

Length is measured from end to end. Height is measured from centerline to top of wheel in full open position.

NOTE: Flat face mating flanges and full face gaskets must be installed to avoid damage to the cast iron body.

MODEL 620F



CLASS 250 FLANGED GATE VALVE

FEATURES

- Compatible with ANSI 250# & 300# Flanges
- Full Port
- Bronze Mounted Seat Rings
- Solid Wedge
- Adjustable Graphite Stem Packing
- Non-Rising Stem
- Flanged Connection
- Bolted Bonnet
- Rugged Iron Hand Wheel
- Back Seat Protection
- Certified NSF/ANSI 372 Lead Free

STANDARDS

MSS SP-70

"Gray Iron Gate Valves Flanged and Threaded"

ASME B16.10

"Face-to-Face and End-to-End Dimensions of Valves"

Series Number	NPS	Length (in.)	Height (in.)	Weight (lb.)
6GA-208-B1	2	8.50	11.28	42.0
6GA-209-B1	2 1/2	9.50	12.72	55.0
6GA-200-B1	3	11.00	13.31	66.0
6GA-20A-B1	4	12.00	16.18	115
6GA-20C-B1	6	16.00	22.00	205
6GA-20E-B1	8	16.50	25.59	278
6GA-20G-B1	10	18.00	30.31	456
6GA-20H-B1	12	19.75	33.90	633

Length is measured from end to end. Height is measured from centerline to top of wheel in full open position.

NOTE: Class 250 flanges and flanged fittings have a 0.06 inch raised face in accordance with MSS SP-6.

GATE, GLOBE & CHECKS

Iron Gate Valves – Apollo International™

MODEL 611F



CLASS 125 FLANGED OS&Y GATE VALVE

FEATURES

- Compatible with ANSI 125# & 150# Flanges
- Full Port
- Bronze Mounted Seat Rings
- Solid Wedge
- Adjustable Graphite Stem Packing
- Outside Screw and Yoke
- Bolted Bonnet
- Back Seat Protection
- Certified NSF/ANSI 372 Lead Free

STANDARDS

MSS SP-70

"Gray Iron Gate Valves Flanged and Threaded"

ASME B16.10

"Face-to-Face and End-to-End Dimensions of Valves"

Series Number	NPS	Length (in.)	Height (in.)	Weight (lb.)
6GA-118-B1	2	7.00	14.96	38.0
6GA-119-B1	2 1/2	7.50	16.93	51.0
6GA-110-B1	3	8.00	19.09	62.0
6GA-11A-B1	4	9.00	24.21	110
6GA-11B-B1	5	10.00	27.56	154
6GA-11C-B1	6	10.50	32.87	203
6GA-11E-B1	8	11.50	37.76	284
6GA-11G-B1	10	13.00	48.03	459
6GA-11H-B1	12	14.00	56.50	637
6GA-11J-B1	14	15.00	65.16	966
6GA-11K-B1	16	16.00	71.85	1135
6GA-11M-B1	18	17.00	79.53	1753
6GA-11N-B1	20	18.00	90.16	2238
6GA-11P-B1	24	20.00	132.28	3197

Length is measured from end to end. Height is measured from centerline to top of wheel in full open position.

NOTE: Flat face mating flanges and full face gaskets must be installed to avoid damage to the cast iron body.

MODEL 621F



CLASS 250 FLANGED OS&Y GATE VALVE

FEATURES

- Compatible with ANSI 250# & 300# Flanges
- Full Port
- Bronze Mounted Seat Rings
- Solid Wedge
- Adjustable Graphite Stem Packing
- Outside Screw and Yoke
- Flanged Connection
- Bolted Bonnet
- Back Seat Protection
- Certified NSF/ANSI 372 Lead Free

STANDARDS

MSS SP-70

"Gray Iron Gate Valves Flanged and Threaded"

ASME B16.10

"Face-to-Face and End-to-End Dimensions of Valves"

Series Number	NPS	Length (in.)	Height (in.)	Weight (lb.)
6GA-218-B1	2	8.50	14.96	44.0
6GA-219-B1	2 1/2	9.50	16.93	57.0
6GA-210-B1	3	11.12	19.09	71.0
6GA-21A-B1	4	12.00	24.21	121
6GA-21B-B1	5	15.00	27.56	165
6GA-21C-B1	6	15.88	32.87	216
6GA-21E-B1	8	16.50	39.76	302
6GA-21G-B1	10	18.00	48.03	481
6GA-21H-B1	12	19.75	56.50	642

Length is measured from end to end. Height is measured from centerline to top of wheel in full open position.

NOTE: Class 250 flanges and flanged fittings have a 0.06 inch raised face in accordance with MSS SP-6.



See Gate, Globe & Check Catalog (GGC9000) for more detailed information about the products in this section.

Customer Service (704) 841-6000

REV. 1-6-15

COMMERCIAL PRODUCTS CATALOG

Bronze Globe Valves – Made in USA



MODEL 120S



Meets MSS SP-80 standard
ASTM B62 bronze materials

SOLDER ENDS GLOBE VALVE

FEATURES

- Threaded Bonnet
- PTFE Disc
- 200 CWP
- Max. Temp: 353°F
- **Lead Free** option (NSF 61/NSF 372)

Model Number	LF Series Number	NPS	Length (in.)	Height (in.)	Weight (lb.)
33-143-01	33LF-143-01	1/2	2.97	3.47	1.00
33-144-01	33LF-144-01	3/4	3.83	4.75	1.90
33-145-01	33LF-145-01	1	4.57	5.40	2.80
33-146-01	33LF-146-01	1 1/4	5.95	7.80	7.30
33-147-01	33LF-147-01	1 1/2	5.95	7.80	6.80
33-148-01	33LF-148-01	2	7.18	8.43	10.60

Length is measured from end to end. Height is measured from centerline to top of wheel in full open position.

MODEL 120T



Meets MSS SP-80 standard
ASTM B62 bronze materials

CLASS 125 NPT GLOBE VALVE

FEATURES

- Threaded Bonnet
- PTFE Disc
- 200 CWP
- 125 SWP
- **Lead Free** option (NSF 61/NSF 372)

Model Number	LF Series Number	NPS	Length (in.)	Height (in.)	Weight (lb.)
33-132-01	33LF-132-01	3/8	2.39	3.37	1.00
33-133-01	33LF-133-01	1/2	2.70	3.47	1.10
33-134-01	33LF-134-01	3/4	3.20	4.75	1.90
33-135-01	33LF-135-01	1	3.75	5.40	3.00
33-136-01	33LF-136-01	1 1/4	4.74	7.78	7.30
33-137-01	33LF-137-01	1 1/2	4.74	7.78	7.00
33-138-01	33LF-138-01	2	5.72	8.43	10.70

Length is measured from end to end. Height is measured from centerline to top of wheel in full open position.

MODEL 121T



Meets MSS SP-80 standard
ASTM B62 bronze materials
MSS SP-139 lead free option (CWP only)

CLASS 125 NPT GLOBE VALVE

FEATURES

- Threaded Bonnet
- Bronze Disc
- 200 CWP
- 125 SWP
- **Lead Free** option (NSF 61/NSF 372)

Series Number	LF Series Number	NPS	Length (in.)	Height (in.)	Weight (lb.)
33-161-01	33LF-161-01	1/4	2.39	3.46	1.00
33-162-01	33LF-162-01	3/8	2.39	3.46	1.00
33-163-01	33LF-163-01	1/2	2.70	3.56	1.10
33-164-01	33LF-164-01	3/4	3.20	4.75	1.90
33-165-01	33LF-165-01	1	3.75	5.40	3.00
33-166-01	33LF-166-01	1 1/4	4.74	7.78	7.30
33-167-01	33LF-167-01	1 1/2	4.74	7.78	7.00
33-168-01	33LF-168-01	2	5.72	8.43	11.00

Length is measured from end to end. Height is measured from centerline to top of wheel in full open position.

GATE, GLOBE & CHECKS

Bronze Globe Valves – Made in USA



MODEL 122T



Meets MSS SP-80 standard
ASTM B62 bronze materials

CLASS 150 NPT GLOBE VALVE

FEATURES

- Union Bonnet
- PTFE Disc
- 300 CWP
- 150 SWP

Series Number	NPS	Length (in.)	Height (in.)	Weight (lb.)
33-221-01	1/4	2.39	4.23	1.40
33-222-01	3/8	2.39	4.23	1.40
33-223-01	1/2	2.70	4.31	1.40
33-224-01	3/4	3.20	4.89	2.20
33-225-01	1	3.75	5.40	3.50
33-226-01	1 1/4	4.74	7.79	7.70
33-227-01	1 1/2	4.74	7.79	7.40
33-228-01	2	5.20	8.76	12.40
33-229-01	2 1/2	6.60	10.07	18.80
33-220-01	3	7.74	11.39	25.50

Length is measured from end to end. Height is measured from centerline to top of wheel in full open position.

MODEL 127T



Meets MSS SP-80 standard
ASTM B61 bronze materials

CLASS 300 NPT GLOBE VALVE

FEATURES

- Union Bonnet
- Bronze Disc and Seat
- 1000 CWP
- 300 SWP

Series Number	NPS	Length (in.)	Height (in.)	Weight (lb.)
33-663-01	1/2	2.70	5.40	1.78
33-664-01	3/4	3.20	5.86	2.28
33-665-01	1	4.00	6.71	4.22
33-666-01	1 1/4	5.25	8.50	8.30
33-667-01	1 1/2	5.25	8.50	8.10
33-668-01	2	6.25	9.75	13.00

Length is measured from end to end. Height is measured from centerline to top of wheel in full open position.

MODEL 128T



Meets MSS SP-80 standard
ASTM B61 bronze materials

CLASS 300 NPT GLOBE VALVE

FEATURES

- Union Bonnet
- Type 420 Stainless Steel Disc and Seat Ring
- 1000 CWP
- 300 SWP

Series Number	NPS	Length (in.)	Height (in.)	Weight (lb.)
33-743-01	1/2	2.70	5.40	1.78
33-744-01	3/4	3.20	5.86	2.28
33-745-01	1	4.00	6.71	4.22
33-746-01	1 1/4	5.25	8.50	8.30
33-747-01	1 1/2	5.25	8.50	8.10
33-748-01	2	6.25	9.75	13.00

Length is measured from end to end. Height is measured from centerline to top of wheel in full open position.



See Gate, Globe & Check Catalog (GGC9000) for more detailed information about the products in this section.

Customer Service (704) 841-6000

COMMERCIAL PRODUCTS CATALOG

Iron Globe Valves – Apollo International™

MODEL 711F



CLASS 125 FLANGED GLOBE VALVE

FEATURES

- Compatible with ANSI 125# & 150# Flanges
- Full Port
- Bronze Mounted Seat Rings
- Positive Shut-Off
- Throttling Capabilities
- Adjustable Graphite Stem Packing
- Outside Screw and Yoke
- Bolted Bonnet
- Back Seat Protection
- Certified NSF/ANSI 372 Lead Free

STANDARDS

MSS SP-85

"Gray Iron Globe & Angle Valves Flanged & Threaded Ends"

ASME B16.10

"Face-to-Face and End-to-End Dimensions of Valves"

Series Number	NPS	Length (in.)	Height (in.)	Weight (lb.)
6GB-118-B1	2	8.00	11.61	36.0
6GB-119-B1	2 1/2	8.50	12.99	49.0
6GB-110-B1	3	9.50	14.37	64.0
6GB-11A-B1	4	11.50	15.75	94.0
6GB-11B-B1	5	13.00	17.72	137
6GB-11C-B1	6	14.00	20.67	195
6GB-11E-B1	8	19.50	23.43	315
6GB-11G-B1	10	24.50	26.97	485

Length is measured from end to end. Height is measured from centerline to top of wheel in full open position.

NOTE: Flat face mating flanges and full face gaskets must be installed to avoid damage to the cast iron body.

MODEL 721F



CLASS 250 FLANGED GLOBE VALVE

FEATURES

- Compatible with ANSI 250# & 300# Flanges
- Full Port
- Bronze Mounted Seat Rings
- Positive Shut-Off
- Throttling Capabilities
- Adjustable Graphite Stem Packing
- Outside Screw and Yoke
- Flanged Connection
- Bolted Bonnet
- Rugged Iron Hand Wheel
- Back Seat Protection
- Certified NSF/ANSI 372 Lead Free

STANDARDS

MSS SP-85

"Gray Iron Globe & Angle Valves Flanged & Threaded Ends"

ASME B16.10

"Face-to-Face and End-to-End Dimensions of Valves"

Series Number	NPS	Length (in.)	Height (in.)	Weight (lb.)
6GB-218-B1	2	10.50	14.17	40.8
6GB-219-B1	2 1/2	11.50	15.75	52.9
6GB-210-B1	3	12.50	16.93	70.5
6GB-21A-B1	4	14.00	18.90	99.2
6GB-21C-B1	6	17.50	23.62	203
6GB-21E-B1	8	21.00	27.56	333

Length is measured from end to end. Height is measured from centerline to top of wheel in full open position.

NOTE: Class 250 flanges and flanged fittings have a 0.06 inch raised face in accordance with MSS SP-6.

GATE, GLOBE & CHECKS

Bronze Swing Check Valves – Made in USA



MODEL 161S



Meets MSS SP-80 standard
ASTM B62 bronze materials
MSS SP-139 lead free option (CWP only)

BRONZE DISC SWING CHECK

FEATURES

- Y-Pattern
- Solder Ends
- Metal Seat
- 200 CWP
- **Lead Free** option (NSF 61/NSF 372)

Model Number	LF Model Number	NPS	Length (in.)	Height (in.)	Weight (lb.)
61Y-093-01	61YLF-093-01	1/2	2.53	1.65	0.62
61Y-094-01	61YLF-094-01	3/4	3.36	1.90	0.91
61Y-095-01	61YLF-095-01	1	4.07	2.26	1.70
61Y-096-01	61YLF-096-01	1 1/4	4.68	2.65	2.00
61Y-097-01	61YLF-097-01	1 1/2	5.28	2.99	2.70
61Y-098-01	61YLF-098-01	2	6.50	3.74	4.90
61Y-099-01	–	2 1/2	8.30	5.11	9.70
61Y-090-01	–	3	9.58	6.05	15.00

Height is measured from centerline to top of unit.

MODEL 161T



Meets MSS SP-80 standard
ASTM B62 bronze materials
MSS SP-139 lead free option (CWP only)

CLASS 125 BRONZE DISC SWING CHECK

FEATURES

- Y-Pattern
- NPT
- Metal Seat
- 200 CWP
- 125 SWP
- **Lead Free** option (NSF 61)

Model Number	LF Model Number	NPS	Length (in.)	Height (in.)	Weight (lb.)
61Y-191-01	61YLF-191-01	1/4	2.14	1.51	0.64
61Y-192-01	61YLF-192-01	3/8	2.14	1.51	0.62
61Y-193-01	61YLF-193-01	1/2	2.48	1.65	0.73
61Y-194-01	61YLF-194-01	3/4	2.94	1.90	1.06
61Y-195-01	61YLF-195-01	1	3.57	2.26	1.70
61Y-196-01	61YLF-196-01	1 1/4	4.50	2.99	3.30
61Y-197-01	61YLF-197-01	1 1/2	4.50	2.99	3.10
61Y-198-01	61YLF-198-01	2	5.25	3.74	5.50
61Y-199-01	–	2 1/2	8.00	5.11	11.70
61Y-190-01	–	3	9.24	6.05	17.80

Height is measured from centerline to top of unit.

MODEL 162T



Meets MSS SP-80 standard
ASTM B62 bronze materials

CLASS 125 VITON® DISC SWING CHECK

FEATURES

- Y-Pattern
- NPT
- Elastomer Seat
- 200 CWP
- 125 SWP

Model Number	NPS	Length (in.)	Height (in.)	Weight (lb.)
61Y-201-V1	1/4	2.14	1.51	0.64
61Y-202-V1	3/8	2.14	1.51	0.62
61Y-203-V1	1/2	2.48	1.65	0.73
61Y-204-V1	3/4	2.94	1.90	1.06
61Y-205-V1	1	3.57	2.26	1.70
61Y-206-V1	1 1/4	4.50	2.99	3.30
61Y-207-V1	1 1/2	4.50	2.99	3.10
61Y-208-V1	2	5.25	3.74	5.40

Height is measured from centerline to top of unit.



See Gate, Globe & Check Catalog (GGC9000) for more detailed information about the products in this section.

Customer Service (704) 841-6000

COMMERCIAL PRODUCTS CATALOG

Bronze Swing Check Valves – Made in USA



MODEL 163S



200 CWP PTFE DISC SWING CHECK

FEATURES

- Y-Pattern
- Solder
- PTFE Soft Seat
- 200 CWP
- **Lead Free** option (NSF 61/NSF 372)

Series Number	LF Series Number	NPS	Length (in.)	Height (in.)	Weight (lb.)
61Y-103-T1	61YLF-103-T1	1/2	2.53	1.65	0.62
61Y-104-T1	61YLF-104-T1	3/4	3.36	1.90	0.91
61Y-105-T1	61YLF-105-T1	1	4.07	2.26	1.70
61Y-106-T1	61YLF-106-T1	1 1/4	5.28	2.99	3.20
61Y-107-T1	61YLF-107-T1	1 1/2	5.28	2.99	2.70
61Y-108-T1	61YLF-108-T1	2	6.50	3.74	4.90

Height is measured from centerline to top of unit.

Meets MSS SP-80 standard
ASTM B62 bronze materials
MSS SP-139 lead free option (CWP only)

MODEL 163T



CLASS 125 PTFE DISC SWING CHECK

FEATURES

- Y-Pattern
- NPT
- PTFE Soft Seat
- 200 CWP
- 125 SWP
- **Lead Free** option (NSF 61/NSF 372)

Series Number	LF Series Number	NPS	Length (in.)	Height (in.)	Weight (lb.)
61Y-201-T1	–	1/4	2.14	1.51	0.64
61Y-202-T1	–	3/8	2.15	1.51	0.62
61Y-203-T1	61YLF-203-T1	1/2	2.48	1.65	0.73
61Y-204-T1	61YLF-204-T1	3/4	2.94	1.90	1.06
61Y-205-T1	61YLF-205-T1	1	3.57	2.26	1.70
61Y-206-T1	61YLF-206-T1	1 1/4	4.50	2.99	3.30
61Y-207-T1	61YLF-207-T1	1 1/2	4.50	2.99	3.10
61Y-208-T1	61YLF-208-T1	2	5.25	3.74	5.40

Height is measured from centerline to top of unit.

Meets MSS SP-80 standard
ASTM B62 bronze materials
MSS SP-139 lead free option (CWP only)

MODEL 164T



CLASS 150 BRONZE DISC SWING CHECK

FEATURES

- Y-Pattern
- NPT
- Metal Seat
- 300 CWP
- 150 SWP

Series Number	NPS	Length (in.)	Height (in.)	Weight (lb.)
61Y-211-01	1/4	2.14	1.51	0.64
61Y-212-01	3/8	2.14	1.51	0.62
61Y-213-01	1/2	2.48	1.65	0.73
61Y-214-01	3/4	2.94	1.90	1.06
61Y-215-01	1	3.57	2.26	1.70
61Y-216-01	1 1/4	4.50	2.99	3.30
61Y-217-01	1 1/2	4.50	2.99	3.10
61Y-218-01	2	5.25	3.74	5.50
61Y-219-01	2 1/2	8.00	5.11	11.70
61Y-210-01	3	9.24	6.05	17.80

Height is measured from centerline to top of unit.

Meets MSS SP-80 standard
ASTM B62 bronze materials

GATE, GLOBE & CHECKS

Bronze Swing Check Valves – Made in USA



MODEL 168T



Meets MSS SP-80 standard
ASTM B61 bronze materials

CLASS 300 BRONZE DISC SWING CHECK

FEATURES

- Y-Pattern
- NPT
- Metal Seat
- 600 CWP
- 300 SWP

Series Number	NPS	Length (in.)	Height (in.)	Weight (lb.)
61Y-753-01	1/2	2.50	1.65	.75
61Y-754-01	3/4	2.95	1.90	1.20
61Y-755-01	1	3.57	2.27	1.80
61Y-756-01	1 1/4	4.50	3.00	3.50
61Y-757-01	1 1/2	4.50	3.00	3.20
61Y-758-01	2	5.25	3.75	5.60

Height is measured from centerline to top of unit.

MODEL 169T



Meets MSS SP-80 standard
ASTM B61 bronze materials

CLASS 300 PTFE DISC SWING CHECK

FEATURES

- Y-Pattern
- NPT
- PTFE Soft Seat
- 600 CWP

Series Number	NPS	Length (in.)	Height (in.)	Weight (lb.)
61Y-753-T1	1/2	2.5	1.65	.75
61Y-754-T1	3/4	2.95	1.90	1.20
61Y-755-T1	1	3.57	2.27	1.80
61Y-756-T1	1 1/4	4.50	3.00	3.50
61Y-757-T1	1 1/2	4.50	3.00	3.20
61Y-758-T1	2	5.25	3.75	5.60

Height is measured from centerline to top of unit.

Iron Swing Check Valves – Apollo International™

MODEL 910F



CLASS 125 FLANGED SWING CHECK

FEATURES

- Compatible with ANSI 125# & 150# Flanges
- Full Port
- Minimal Pressure Drop
- Bolted Bonnet
- Integral Bronze Seat
- Certified NSF/ANSI 372 Lead Free

STANDARDS

MSS SP-71

“Gray Iron Swing Check Valves
Flanged and Threaded”

ASME B16.10

“Face-to-Face and End-to-End
Dimensions of Valves”

Series Number	NPS	Length (in.)	Height (in.)	Weight (lb.)
65C-108-B1	2	8.00	4.41	26.0
65C-109-B1	2 1/2	8.50	5.24	39.0
65C-100-B1	3	9.50	5.67	47.0
65C-10A-B1	4	11.50	6.61	82.0
65C-10B-B1	5	13.00	7.80	124
65C-10C-B1	6	14.00	8.54	160
65C-10E-01	8	19.50	10.28	271
65C-10G-01	10	24.50	11.30	437
65C-10H-01	12	27.50	12.56	644
65C-10J-01	14	31.00	17.50	950
65C-10K-01	16	36.00	23.45	1160
65C-10M-01	18	36.00	27.50	1720
65C-10N-01	20	40.00	29.25	2094

Height is measured from centerline to top of unit.

NOTE: Flat face mating flanges and full face gaskets must be installed to avoid damage to the cast iron body.



See Gate, Globe & Check Catalog (GGC9000) for more detailed information about the products in this section.

Customer Service (704) 841-6000

REV. 1-6-15

COMMERCIAL PRODUCTS CATALOG

Iron Swing Check Valves – Apollo International™

MODEL 910FLW



CLASS 125 FLANGED SWING CHECK

FEATURES

- Compatible with ANSI 125# & 150# Flanges
- Full Port
- Minimal Pressure Drop
- Bolted Bonnet
- Integral Seat
- Lever and Weight Design
- Certified NSF/ANSI 372 Lead Free

STANDARDS

MSS SP-71

"Gray Iron Swing Check Valves Flanged & Threaded"

ASME B16.10

"Face-to-Face and End-to-End Dimensions of Valves"

Series Number	NPS	Length (in.)	Height (in.)	Weight (lb.)
6SC-108-B1L	2	8.00	4.41	38.8
6SC-109-B1L	2 1/2	8.50	5.24	45.2
6SC-100-B1L	3	9.50	5.67	61.7
6SC-10A-B1L	4	11.50	6.61	99.2
6SC-10B-B1L	5	13.00	7.80	132
6SC-10C-B1L	6	14.00	8.54	170
6SC-10E-01L	8	19.50	10.28	282
6SC-10G-01L	10	24.50	11.30	439
6SC-10H-01L	12	27.50	12.56	672

Height is measured from centerline to top of unit.

NOTE: Flat face mating flanges and full face gaskets must be installed to avoid damage to the cast iron body.

MODEL 920F



CLASS 250 FLANGED SWING CHECK

FEATURES

- Compatible with ANSI 250# & 300# Flanges
- Full Port
- Minimal Pressure Drop
- Bolted Bonnet
- Integral Seat
- Certified NSF/ANSI 372 Lead Free

STANDARDS

MSS SP-71

"Gray Iron Swing Check Valves Flanged & Threaded"

ASME B16.10

"Face-to-Face and End-to-End Dimensions of Valves"

Series Number	NPS	Length (in.)	Height (in.)	Weight (lb.)
6SC-208-B1	2	10.51	4.41	30.0
6SC-209-B1	2 1/2	11.50	5.24	44.0
6SC-200-B1	3	12.50	5.67	55.0
6SC-20A-B1	4	14.00	6.61	90.0
6SC-20C-B1	6	17.50	8.54	172
6SC-20E-01	8	21.00	10.28	289

Height is measured from centerline to top of unit.

NOTE: Class 250 flanges and flanged fittings have a 0.06 inch raised face in accordance with MSS SP-6.

GATE, GLOBE & CHECKS

Iron Wafer Checks – Apollo International™

MODEL 910WB



Cold Working Pressure:

200 psi (13.8 Bar) at 100°F (2-12")

150 psi (10.3 Bar) at 100°F (14-24")

Temperature Range:

10°F to 180°F

CLASS 125 WAFER CHECK - NITRILE (BUNA-N)

FEATURES

- Compatible with ANSI 125# & 150# Flanges
- Full Port
- Minimal Pressure Drop
- Light Weight
- Spring Assisted Closing for Quicker Response
- Certified NSF/ANSI 372 Lead Free

Series Number	NPS	Length (in.)	Height (in.)	Weight (lb.)
6WC-108-N1	2	2.21	4.00	5.0
6WC-109-N1	2 1/2	2.38	4.75	7.0
6WC-100-N1	3	2.62	5.25	10.0
6WC-10A-N1	4	2.62	6.75	12.0
6WC-10B-N1	5	3.25	7.50	15.0
6WC-10C-N1	6	3.75	8.50	22.0
6WC-10E-N1	8	5.00	11.00	35.0
6WC-10G-N1	10	5.50	13.25	66.0
6WC-10H-N1	12	7.12	16.00	108
6WC-10J-N1	14	7.25	17.75	172
6WC-10K-N1	16	7.50	20.00	132
6WC-10M-N1	18	8.00	21.50	223
6WC-10N-N1	20	8.38	23.75	333
6WC-10P-N1	24	8.75	28.00	474

MODEL 910WE



Cold Working Pressure:

200 psi (13.8 Bar) at 100°F

Temperature Range:

-30°F to 275°F

CLASS 125 WAFER CHECK - EPDM

FEATURES

- Compatible with ANSI 125# & 150# Flanges
- Full Port
- Minimal Pressure Drop
- Light Weight
- Spring Assisted Closing for Quicker Response
- Certified NSF/ANSI 372 Lead Free

Series Number	NPS	Length (in.)	Height (in.)	Weight (lb.)
6WC-108-E1	2	2.12	4.00	5.0
6WC-109-E1	2 1/2	2.38	4.75	7.0
6WC-100-E1	3	2.62	5.25	10.0
6WC-10A-E1	4	2.62	6.75	12.0
6WC-10B-E1	5	3.25	7.50	15.0
6WC-10C-E1	6	3.75	8.50	22.0
6WC-10E-E1	8	5.00	11.00	35.0
6WC-10G-E1	10	5.50	13.25	66.0
6WC-10H-E1	12	7.12	16.00	108

COMMERCIAL PRODUCTS CATALOG

Specialty Valves

70-100-BC SERIES

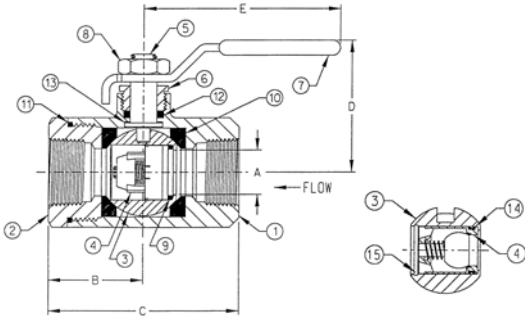

BALL VALVES WITH INTEGRAL CHECK, FEMALE X FEMALE

Combines two functions in a single design: positive shut-off and bubble tight check capabilities. The BC Series is a unidirectional version of the industry standard Apollo 70 Series ball valve.

FEATURES

- Blowout-proof stem
- RPTFE seats and stem packing
- Adjustable packing gland
- ASTM B584 Bronze
- Nitrile elastomers in Acetal check housing
- Positive shut-off and bubble-tight check capability
- 250 psi @ 200°F max

Model Number	Size (in.)	Dimensions (in.)					Wt.
		A	B	C	D	E	
70-103-BC	1/2"	0.50	1.12	2.25	1.80	3.87	0.63
70-104-BC	3/4"	0.68	4.50	3.00	2.12	4.87	1.33
70-105-BC	1"	0.87	1.68	3.37	2.25	4.87	1.77
70-106-BC	1-1/4"	1.00	2.00	4.00	2.73	5.50	3.29
70-107-BC	1-1/2"	1.25	2.18	4.37	3.09	8.00	4.63
70-108-BC	2"	1.50	2.34	4.68	3.28	8.00	6.01

In-Line Check Valves

CVB (61-100 & 61-200) SERIES

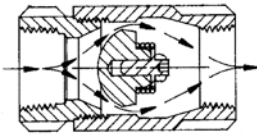
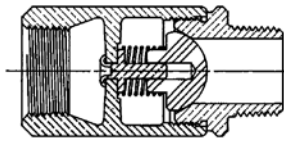

BALL CONE® CHECK VALVES

Patented design (U.S. Pat. No. 4,172,465) with reinforced RPTFE ball-cone check and stainless steel springs, these valves offer reliable protection against reverse flow and exceptional resistance to chemicals and corrosion.

FEATURES

- Standard 1/2" psi opening pressure
- Tight shut-off with liquid media
- Male and female NPT inlet options
- 400 psig CWP @ 100°F
- 125 psig steam rating @ 350°F max
- Straight-through design minimizes pressure loss
- ASTM B584 Bronze
- American-made construction
- **Lead Free** option (61LF)(NSF 61/NSF 372)

Bronze FNPT x FNPT	LF Bronze FNPT x FNPT	Bronze MNPT x FNPT	Size (in.)	Wt. Ea.	Cv
61-101-01	61LF-101-01	61-201-01	1/4	.38	.85
61-102-01	61LF-102-01	61-202-01	3/8	.38	1.2
61-103-01	61LF-103-01	61-203-01	1/2	.38	1.4
61-104-01	61LF-104-01	61-204-01	3/4	.75	3.5
61-105-01	61LF-105-01	61-205-01	1	1.45	6.0
61-106-01	61LF-106-01	61-206-01	1 1/4	2.75	44
61-107-01	61LF-107-01	61-207-01	1 1/2	3.94	65
61-108-01	61LF-108-01	61-208-01	2	6.30	81
61-109-01	61LF-109-01	-	2 1/2	14.00	175
61-100-01	61LF-100-01	-	3	16.65	265

Precautionary Note: Not recommended for use with reciprocating pumps and similar applications which may induce repetitious vibrations. Low flow rates which do not fully open the valve, may result in undesirable noise and premature valve failure. Upstream flow disturbances, which create turbulence, may also result in rapid wear. Therefore, it is recommended that a minimum of 10 diameters of straight pipe be provided between the check valve and any upstream flow disturbances such as pumps, control valves, elbows, etc.

GATE, GLOBE & CHECKS

In-Line Check Valves

CVS (62-100) SERIES

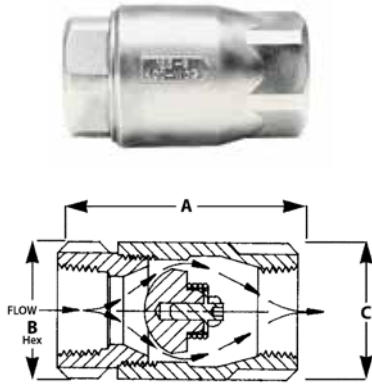

STAINLESS STEEL BALL CONE® CHECK VALVES

The 62-100 Series is uniquely suited for applications in corrosive environments, including chemical processing, pulp and paper and other process industries. The rugged stainless steel body and RPTFE ball check provide reliable, patented protection against reverse flow.

FEATURES

- Unique design (U.S. Patent # 4,172,465)
- Spring-loaded for fast seating action
- Center guided so that radial alignment is never needed
- Straight-through flow minimizes pressure loss
- 400 psig CWP non-shock @ 100°F
- 125 psig SWP @ 350°F
- RoHS Compliant
- ASTM A351, CF8M

Model Number	Size (in.)	Dimensions (in.)			Wt. Ea. (lbs.)	Cv
		A	B	C		
62-101-01	1/4	2.06	1.12	1.12	.38	.85
62-102-01	3/8	2.12	1.12	1.12	.38	1.21
62-103-01	1/2	2.31	1.12	1.12	.38	1.40
62-104-01	3/4	2.87	1.37	1.50	.75	3.5
62-105-01	1	3.50	1.75	1.93	1.45	6.0
62-106-01	1-1/4	4.18	2.12	2.37	2.37	44
62-107-01	1-1/2	4.93	2.50	2.81	3.81	65
62-108-01	2	6.00	3.00	3.68	6.36	81

CVBE & CVSE (61-500 & 62-500) SERIES



IN-LINE SOFT SEAT CHECK VALVES

Fabricated with stainless steel springs and elastomeric seats for tighter shut-off. No radial alignment is needed. Exceptional resistance to chemicals and corrosion.

FEATURES

- Female NPT sizes: 1/4" to 2"
- Stainless steel sizes: 1/4" to 1"
- Bubble-tight shut-off, ideally suited for gaseous service
- NPT threaded; 400 psig CWP non-shock @ 100°F
- EPDM check disc (61500)
- Viton® check disc (62500)
- Straight-through design minimizes pressure loss
- 1/2 psi cracking pressure
- RoHS Compliant (61LF and 62 Series)

Bronze FNPT x FNPT	61LF-500	SS FNPT x FNPT	Size (in.)	Dimensions (in.)			61 Series Wt. Ea.	Cv
				A	B	C		
61-501-01	61LF-501-01	62-501-01	1/4	2.312	1.125	1.125	.38	.75
61-502-01	61LF-502-01	62-502-01	3/8	2.312	1.125	1.125	.38	1.0
61-503-01	61LF-503-01	62-503-01	1/2	2.312	1.125	1.125	.38	1.2
61-504-01	61LF-504-01	62-504-01	3/4	2.875	1.375	1.500	.75	3.0
61-505-01	61LF-505-01	62-505-01	1	3.500	1.750	1.937	1.45	5.5
61-506-01	61LF-506-01	—	1-1/4	4.187	2.125	2.375	2.75	42
61-507-01	61LF-507-01	—	1-1/2	4.937	2.500	2.812	3.94	60
61-508-01	61LF-508-01	—	2	6.000	3.000	3.687	6.30	75

Precautionary Note: Not recommended for use with reciprocating pumps and similar applications which may induce repetitious vibrations. Low flow rates which do not fully open the valve may result in undesirable noise and premature valve failure. Upstream flow disturbances, which create turbulence, may also result in rapid wear. Therefore, it is recommended that a minimum of 10 diameters of straight pipe be provided between the check valve and any upstream flow disturbances such as pumps, control valves, elbows, etc.

COMMERCIAL PRODUCTS CATALOG

In-Line Check Valves

CVBES (61-600) SERIES

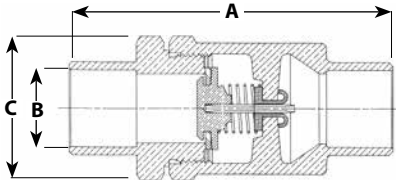

SOLDER END SOFT SEAT CHECK VALVES

All bronze with stainless steel springs and elastomeric seats for tighter shut-off. No radial alignment is needed. Exceptional resistance to corrosion.

FEATURES

- Bubble-tight shut-off, ideally suited for gaseous service
- Straight-through design minimizes pressure loss
- Solder end
- 400 psig CWP non-shock @ 100°F, 250°F max.
- 1/2 psi cracking pressure
- EPDM soft seat is standard

Model Number	LF Model Number	Size (in.)	Dimensions (in.)			Wt.
			A	B	C	
61-603-01	61LF-603-01	1/2	2.72	.629	1.25	.50
61-604-01	61LF-604-01	3/4	3.67	.881	1.65	.86
61-605-01	61LF-605-01	1	4.48	1.13	2.10	1.71
61-606-01	61LF-606-01	1-1/4	6.11	1.38	2.38	2.75
61-607-01	61LF-607-01	1-1/2	6.87	1.63	2.81	3.94
61-608-01	61LF-608-01	2	7.46	2.13	3.75	6.30

CV (61-700) SERIES

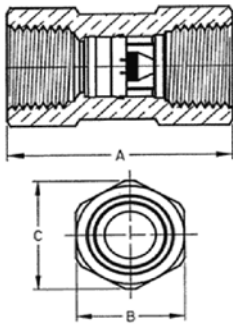

BRASS NPT "MINI" CHECK VALVES

Ideally suited for all OEM applications where space is a premium. Excellent for use on non-potable water and air. Features a bubble-tight soft seat design with a very light loaded stainless steel spring. Rated at 250 psig CWP with a maximum temperature of 180°F.

FEATURES

- Sizes: 1/4" to 1"
- FNPT x FNPT
- Check valve body is Acetyl
- Check seals are Nitrile (Buna-N)
- ASTM B16 brass housing
- Check opening pressure is .5 psi

Model Number	Size (in.)	Dimensions (in.)			Wt.
		A	B	C	
61-701-01	1/4	1.72	0.81	0.92	.22
61-702-01	3/8	1.79	0.93	1.05	.29
61-703-01	1/2	2.02	1.06	1.17	.38
61-704-01	3/4	2.50	1.25	1.40	.54
61-705-01	1	2.95	1.62	1.76	1.10



STRAINERS

STRAINERS



STRAINERS

Bronze "Y" Strainers

YB (59) SERIES

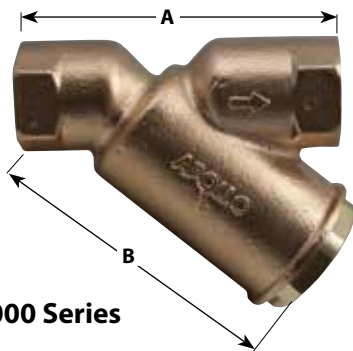

59-000 Series



59-400 Series
F x MNPT



-06 Option

Large volume design for excellent protection against foreign particles in your fluid system. Corrosion-resistant bronze body and stainless steel screens provide years of service.

FEATURES

- Blowout ball valve option
- Operating pressure to 400 CWP at 150°F (up to 3")
- 125 psig SWP
- Removable self-aligning screen
- Large net flow area for longer maintenance intervals
- 59-400 Series is female x male NPT (3/4" & 1" only)
- CRN-OE 8959.5
- UL listed METZ2, oil burner component
- **Lead-Free** option (59LF) is NSF/ANSI 372 Lead Free
- Several screen and cap options
- Made in USA, ARRA compliant

STANDARD

Size (in.)	Standard Screen
1/8 to 1/2	50 Mesh
3/4 to 3	20 Mesh
4	.125 Perforation

OPTIONS

Suffix	Option
-01	Plain Cap
-02	Blowout Tap
-P2	Blowout with Plug
-06	Ball Valve
-E1	20 Mesh
-A1	40 Mesh
-B1	60 Mesh
-C1	80 Mesh
-H1	100 Mesh

Ordering Number	LF Ordering Number	Model Number	Size	Dimensions		Cap Tapping Suffix -02	Wt./Ea. Lbs.	Net Screen Area (in.) ²
				A (in.)	B (in.)			
59-000-01	59LF-000-01	YB14	1/8 NPT	2.00	1.25	1/8 NPT	.4	2.3
59-001-01	59LF-001-01	YB14	1/4 NPT	2.00	1.25	1/8 NPT	.4	2.3
59-002-01	59LF-002-01	YB38	3/8 NPT	2.69	2.00	1/4 NPT	.8	3.2
59-003-01	59LF-003-01	YB12	1/2 NPT	2.69	2.00	1/4 NPT	.8	3.2
59-004-01	59LF-004-01	YB34	3/4 NPT	4.25	3.25	1/2 NPT	1.9	6.7
59-005-01	59LF-005-01	YB1	1 NPT	4.75	4.00	3/4 NPT	2.8	10.8
59-006-01	59LF-006-01	YB114	1-1/4 NPT	5.13	4.25	3/4 NPT	3.6	13.5
59-007-01	59LF-007-01	YB112	1-1/2 NPT	5.75	5.00	1 NPT	5.4	19.0
59-008-01	59LF-008-01	YB2	2 NPT	6.66	6.00	1-1/4 NPT	7.5	27.6
59-009-01	59LF-009-01	YB212	2-1/2 NPT	8.24	5.87	1-1/4 NPT	11.3	41.0
59-010-01	59LF-010-01	YB3	3 NPT	9	6.87	1-1/2 NPT	15.8	56.0
59-011-01	59LF-011-01	YB4	4 NPT	11.92	10.12	1-1/2 NPT	30.7	98
59-404-01	59LF-404-01	YBM34	3/4 F x MNPT	NA	3.25	1/2 NPT	2.0	6.7
59-405-01	59LF-405-01	YBM1	1 F x MNPT	NA	4.00	3/4 NPT	3.0	10.8



Ordering Number	Size	Dimensions		Cap Tapping Suffix -02	Wt./Ea. Lbs.	Net Screen Area (in.) ²
		A (in.)	B (in.)			
UL Listed Strainers						
59-UL0-01	1/8	2.00	1.25	1/8 NPT	.44	1.38
59-UL1-01	1/4	2.00	1.75	1/8 NPT	.42	1.38
59-UL2-01	3/8	2.69	2.00	1/4 NPT	.78	3.19
59-UL3-01	1/2	2.69	2.00	1/4 NPT	.75	3.19



For additional information, submittal sheets and manuals, visit www.apollovalves.com

Customer Service (704) 841-6000

REV. 8-28-14

COMMERCIAL PRODUCTS CATALOG

Bronze End "Y" Strainers

YBS (59-300) SERIES

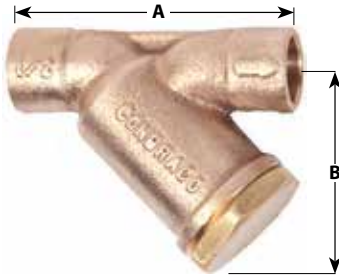

STANDARD

Size (in.)	Standard Screen
1/2	50 Mesh
3/4 to 3	20 Mesh

OPTIONS

Suffix	Option
-01	Solid cap (standard)
-02	Blowout Tap
-P2	Blowout with pipe plug

Designed with minimal wall thickness at solder ends to allow ease of installation. Corrosion-resistant bronze bodies, stainless steel screens with large screen area.

FEATURES

- Operating pressures to 400 CWP at 150°F
- Sizes: 1/2" to 3" copper tube size
- Optional tapped caps available
- **Lead-Free** option (59LF-300) is NSF/ANSI 372 Lead Free
- 59LF features EZ-Solder™ bronze

Series Number	LF Series Number	Size (in.)	Dimensions (in.)		Tapped Cap Suffix -02	Wt.	Net Screen Area (in. ²)
			A	B			
59-303-01	59LF-303-01	1/2	2.75	2.0	1/4 NPT	.50	3.19
59-304-01	59LF-304-01	3/4	4.00	3.0	1/2 NPT	1.21	6.7
59-305-01	59LF-305-01	1	4.75	3.5	3/4 NPT	1.89	10.8
59-306-01	59LF-306-01	1-1/4	5.25	4.0	3/4 NPT	2.80	13.5
59-307-01	59LF-307-01	1-1/2	6.00	4.4	1 NPT	4.26	19.0
59-308-01	59LF-308-01	2	7.25	5.1	1-1/4 NPT	6.27	27.6
59-309-01	59LF-309-01	2-1/2	9.50	5.6	1-1/2 NPT	11.00	41.0
59-310-01	59LF-310-01	3	10.50	6.7	1-1/2 NPT	15.0	56.0

YVB (59V) SERIES

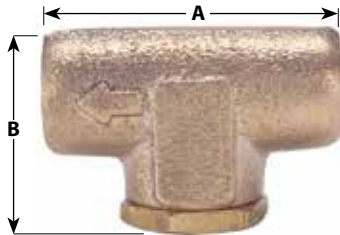

"MINI" STRAINER

The body of the 59-V is corrosion-resistant solid cast bronze, ASTM B-584. The removable clean-out cap is solid brass, ASTM B-16. Standard screens are made of 304 stainless steel. **Not intended for potable water.**

FEATURES

- Cv Factor 1.42 GPM
- Working Pressure (non-shock): 400 CWP

Series Number	Size (in.)	Dimensions (in.)		Wt./100	Screen Mesh
		A	B		
59V-001-01	1/4 NPT	2.00	1.31	29.7	50
59V-001-H1	1/4 NPT	2.00	1.31	29.7	100

YSS (612) SERIES

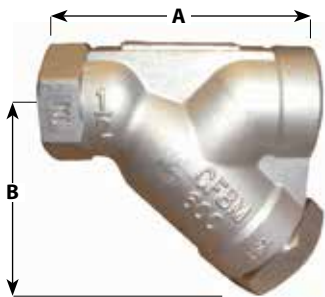

STAINLESS STEEL "Y" STRAINERS

Sturdy and compact with corrosion-resistant stainless steel bodies and stainless steel screens.

FEATURES

- Body is ASTM A351 Stainless Steel Grade CF8M
- 20 mesh screen standard, others available
- Gasket 304 SS/Graphite on 1/2" to 1", (not available in 1-1/4" size)
- Working pressure: 600 psig @ 1124°F steam
1440 psig @ 100°F water, oil, & gas
- Screen cover is NPT tapped for customer supplied plug or blow-off valve

Series Number	Size (in.)	Dimensions (in.)		Blow-off NPT	Wt. (lbs.)	Net Screen Area (in. ²)
		A	B			
612-033-A1	1/2	3.38	2.75	3/8	2	5.4
612-034-A1	3/4	4.44	3.63	3/8	3.75	8.7
612-035-A1	1	4.88	3.75	1/2	4	12.7

STRAINERS

Apollo International Strainers

YCT SERIES

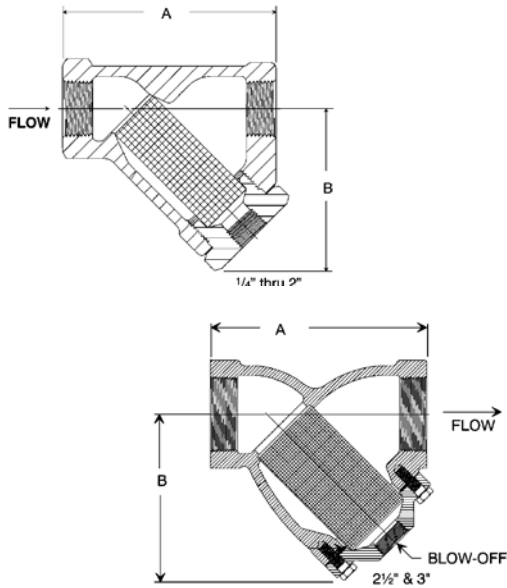

CAST IRON "Y" STRAINER

Install these durable strainers upstream in almost any application to protect valves, regulators, solenoids and meters from rust, dirt and pipe scale.

FEATURES

- 20 mesh screens standard to 2"; .045 perf 2-1/2" to 3", others available
- Graphite gasketed cover for easy screen cleaning
- Standard tapped cap with plug
- Sizes: 1/4" to 3"
- Working Pressure (non-shock)
250 psig @ 406°F. Steam
400 psig @ 150°F. Water, Oil, Gas

Series Number	Size (in.)	Dimensions (in.)		Blow-off NPT	Wt. (lbs.)	Net Screen Area (in. ²)
		A	B			
YCT01M20	1/4	3.19	2.00	1/4	1.5	2.8
YCT02M20	3/8	3.19	2.00	1/4	1.5	2.8
YCT03M20	1/2	3.19	2.00	1/4	1.5	2.8
YCT04M20	3/4	3.75	2.69	3/8	2.5	4.7
YCT05M20	1	4.00	3.00	3/8	3.0	7.0
YCT06M20	1-1/4	5.00	3.44	3/4	6.0	12.1
YCT07M20	1-1/2	5.75	3.78	3/4	8.0	16.4
YCT08M20	2	7.00	4.34	1	14.0	23.1
YCT09P045	2-1/2	9.25	6.09	1-1/2	29.0	55.0
YCT00P045	3	10.00	7.41	1-1/2	38.0	78.4

YCS/YCSW (612) SERIES

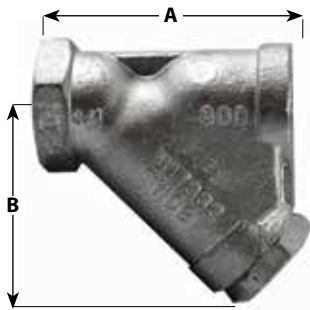

CARBON STEEL "Y" STRAINERS

Large volume area screen, reliable construction.

FEATURES

- Body is ASTM A216 carbon steel Grade WCB
- 20 mesh screen standard, others available
- Copper Gasket 1/2" to 1-1/2"; 304 SS/Graphite on 2"
- Working pressure: 600 psig @ 839°F steam, 1480 psig @ 100°F water, oil, & gas
- Screen cover is NPT tapped for customer supplied plug or blow-off valve

Series Number		Size (in.)	Dimensions (in.)		Blow-off NPT	Wt. (lbs.)	Net Screen Area (in. ²)
Threaded NPT	Socket Weld		A	B			
612023A1	612123A1	1/2	3.38	2.75	3/8	2	5.4
612024A1	612124A1	3/4	4.44	3.63	3/8	3.75	8.7
612025A1	612125A1	1	4.88	3.75	1/2	4	12.7
612027A1	612127A1	1-1/2	6.38	5.13	3/4	8.75	25.3
612028A1	612128A1	2	7.50	6.00	1	12	39.2

COMMERCIAL PRODUCTS CATALOG

Iron Pipe Flanged "Y" Strainers

125YF

IRON PIPE FLANGED "Y" STRAINERS

FEATURES

- Iron strainers are complete with Flat Face flanges in accordance with ASME B16.1
- Strainer body meets applicable ASME Standard
- One piece cast body
- Strainers equipped with bolted cover flange utilizing a flat gasket seal
- Low pressure drop
- Upper and lower machined seats
- 304 SS perforated screens are standard
- Drain/Blow-off connection furnished with plug as standard.
- Generous screen area and properly proportioned straining chamber to minimize initial pressure drop while maximizing time between cleanings
- Compact end to end dimension
- Optional Epoxy coating is FDA approved

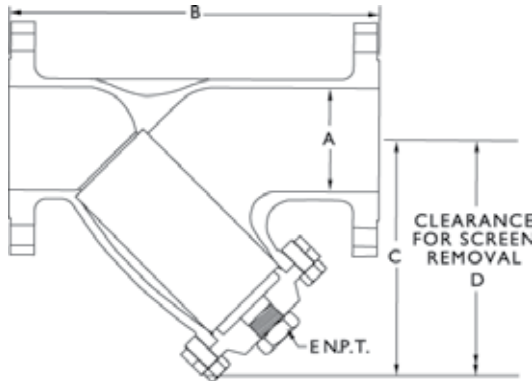

Part	Standard Material
Apollo Model	125YF
Body	A126-B
Cover	A126-B
Screen 1	304 SS
Plug 2	A126-B
Gasket 1	Graphite
Bolt/Stud 2	A307-B
Nut 2	A563

Notes:

1. Recommended Spares.
2. Materials of equivalent strength may be substituted at manufacturer's option.

Model Number*	Size (in.)	Size (mm.)	Dimensions										Wt. (H/ Kg)	Wt. (H/ Kg)
			A (in.)	A (mm.)	B (in.)	B (mm.)	C (in.)	C (mm.)	D (in.)	D (mm.)	E (in.)	E (mm.)		
125YF02P045	2"	50	2.00	51	8.88	226	6.00	152	8.50	216	1/2	15	22	10
125YF25P045	2-1/2"	65	2.50	64	10.75	273	8.00	203	11.25	286	1	25	35	16
125YF03P045	3"	80	3.00	76	11.50	292	8.75	222	12.25	311	1	25	43	20
125YF04P125	4"	100	4.00	102	13.88	353	9.50	241	13.38	340	1-1/4	32	75	34
125YF05P125	5"	125	5.00	127	16.38	416	11.50	292	16.13	410	1-1/4	32	115	52
125YF06P125	6"	150	6.00	152	18.50	470	12.63	321	17.69	449	1-1/2	40	154	70
125YF08P125	8"	200	8.00	203	21.38	543	16.38	416	23.00	584	1-1/2	40	243	110
125YF10P125	10"	250	10.00	254	26.00	660	19.00	483	26.70	678	2	50	390	177
125YF12P125	12"	300	12.00	305	30.00	762	22.00	559	31.00	787	2	50	650	295
125YF14P125	14"	350	14.00	356	37.38	949	29.00	737	41.00	1041	2	50	815	370
125YF16P125	16"	400	16.00	406	42.50	1080	33.00	838	46.00	1168	2	50	1224	555

* Standard mesh models shown.

UNDER PRESSURE LIMITS (NON-SHOCK)

Apollo Model 125YF (up to 12" size)	Apollo Model 125YF (sizes 14" and up)
<u>Body Material</u> A126-B Cast iron	<u>Body Material</u> A126-B Cast iron
<u>M.A.W.P.</u> <u>PSIG (Bars)</u> 200 (13.79)	<u>M.A.W.P.</u> <u>PSIG (Bars)</u> 150 (10.34)

Body Material	Lower Limit °F (°C)
A126-B, A395	-20 (-28.9)

125Y	F - XX	XXXXX	X
PART	VALVE TYPE CONNECTION /SIZE	SCREEN TYPE	COATING
125Y (Flat Face)	Flanged 2" = 02 Flanged 2.5" = 25 Flanged 3" = 03 Flanged 4" = 04 Flanged 5" = 05 Flanged 6" = 06 Flanged 8" = 08 Flanged 10" = 10 Flanged 12" = 12 Flanged 14" = 14 Flanged 16" = 16	20 Mesh = M20 40 Mesh = M40 60 Mesh = M60 80 Mesh = M80 100 Mesh = M100 .045 Perf = P045 .062 Perf = P062 .125 Perf = P125 .250 Perf = P250	Blank = Painted finish (standard) E = Epoxy Coating, FDA Approved

Notes: *All mesh screens are reinforced with a perforated liner.

Standard Screens - 2" - 3": .045 Perf 4" - Larger: .125 Perf

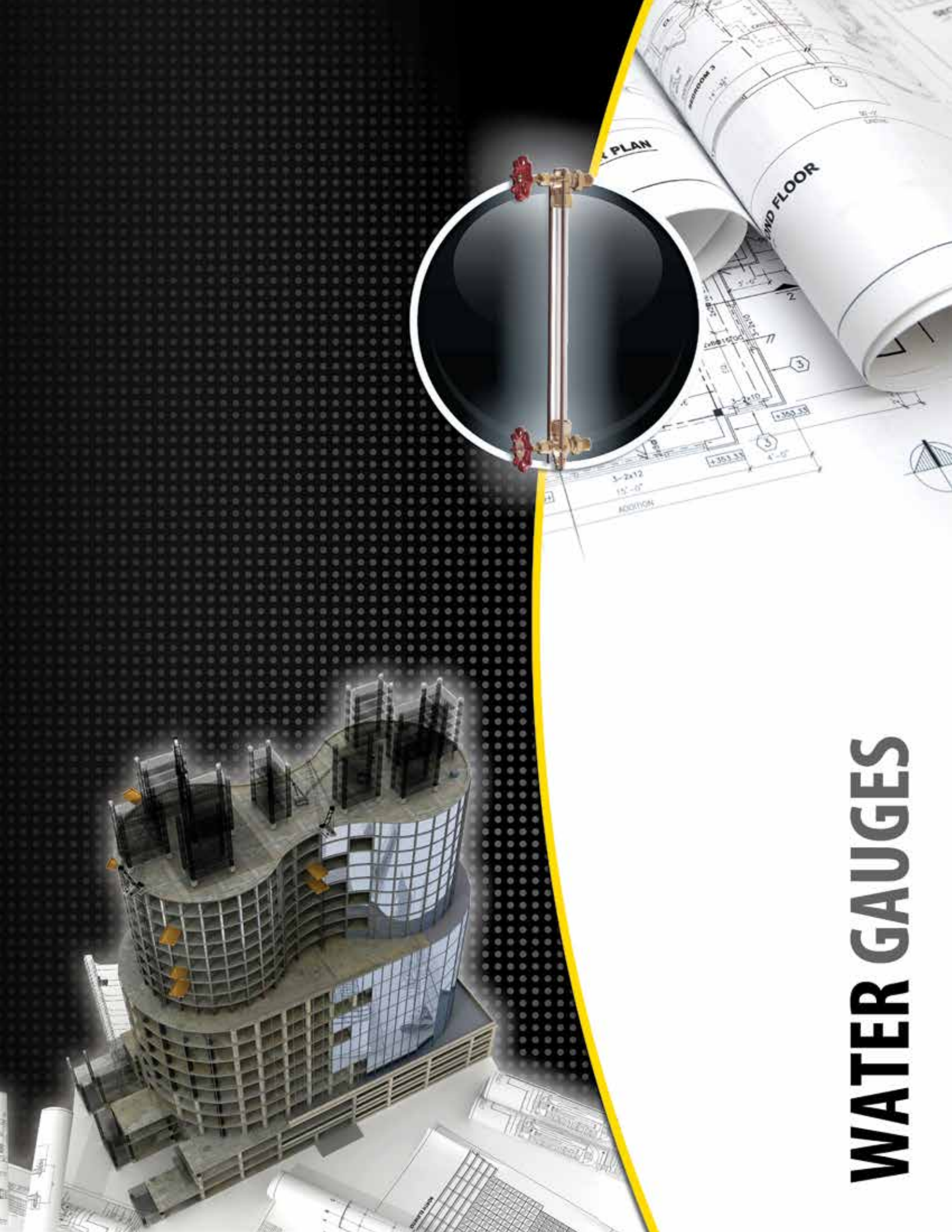

WATER GAUGES

WATER GAUGES



See *Water Gauge/Liquid Level Catalog (PHBRWGA)* for more detailed information about the products in this section.

WATER GAUGES

20-100 SERIES



LEAD FREE OPTION COMING SOON!
(20LF-104 and 20LF-105)



LIGHT PATTERN BRONZE WATER GAUGES

Use for all types of liquid level verification; available with 3/8" or 1/2" NPT male pipe connections. Aluminum or plastic composition hand wheels; EPDM gauge glass gaskets standard. Other glass gaskets available. Automatic ball checks help prevent the loss of fluids should the glass break.

FEATURES

- Ball checks on 20-150 models
- Equipped with two metal guard rods for glass protection
- 1/4" needle drain valve in lower body
- CRN OF6616.5C
- Rated: 125 psig @ 350°F, 300 psig @ 100°F (See note)
- EPDM glass gasket
- TFE stem packing

Part Number	Pipe Size (in.)	Glass O.D. & Length	Wt./100 (lbs.)	Wheel Type
20-101	3/8	5/8 x 10	145	ALUMINUM
20-102	3/8	5/8 x 10	145	COMPOSITION
20-104	1/2	5/8 x 12	160	ALUMINUM
20-105	1/2	5/8 x 12	160	COMPOSITION
20-150*	1/2	5/8 x 12	160	ALUMINUM
20-151*	1/2	5/8 x 12	160	COMPOSITION

Note: Service ratings are subject to pressure/temperature ratings of gauge glass and glass gaskets.

* Automatic ball checks

20-200 SERIES



STANDARD PATTERN BRONZE WATER GAUGES

All standard 20 Series features but with a heavier valve body pattern for higher service ratings.

FEATURES

- Available with 3/8", 1/2" and 3/4" MNPT fittings
- Ball checks standard on 20-250 models
- Polished finish on 25-200 valves
- Rated: 200 psig @ 400°F, 400 psig @ 100°F (See note!)
- CRN OF6616.5C
- EPDM glass gasket
- TFE stem packing

Part Number	Pipe Size (in.)	Glass O.D. & Length	Wt./100 (lbs.)	Wheel Type
20-201	3/8	5/8 x 10	185	ALUMINUM
20-202	3/8	5/8 x 10	189	COMPOSITION
20-204	1/2	5/8 x 12	205	ALUMINUM
20-205	1/2	5/8 x 12	205	COMPOSITION
20-207	3/4	3/4 x 16	270	ALUMINUM
20-208	3/4	3/4 x 16	270	COMPOSITION
20-250*	1/2	5/8 x 12	195	ALUMINUM
20-251*	1/2	5/8 x 12	200	COMPOSITION
20-253*	3/4	3/4 x 16	355	ALUMINUM
20-254*	3/4	3/4 x 16	360	COMPOSITION
25-201	3/8	5/8 x 10	180	ALUMINUM
25-202	3/8	5/8 x 10	185	COMPOSITION
25-204	1/2	5/8 x 12	190	ALUMINUM
25-205	1/2	5/8 x 12	190	COMPOSITION
25-207	3/4	3/4 x 16	290	ALUMINUM
25-208	3/4	3/4 x 16	295	COMPOSITION

Note: Service ratings are subject to pressure/temperature ratings of gauge glass and glass gaskets.

* Automatic ball checks



See Suffix Key on page 162 or Water Gauges/Liquid Level Catalog (PHBRWGA) for more detailed information about the products in this section.

Customer Service (704) 841-6000

COMMERCIAL PRODUCTS CATALOG

20-300 SERIES

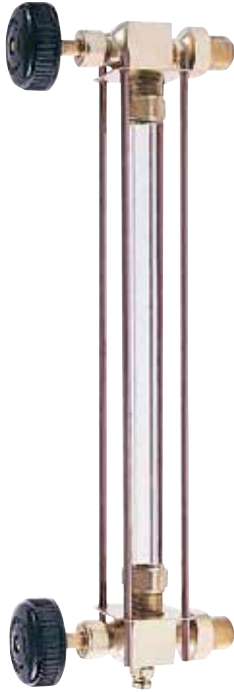

STANDARD PATTERN BRASS WATER GAUGES

Available with 1/2" or 3/4" NPT male pipe connections. Four guard rods and EPDM gauge glass gaskets standard. Other glass gaskets available. Automatic ball checks help prevent the loss of fluids should the glass break.

FEATURES

- Standard 1/4" needle drain valve in lower body
- Pet cock or Apollo® ball valve drain option
- Polished finish on 25-400 and 25-500
- Ball checks standard on 20-350 and 25-500
- Rated: 200 psig @ 400°F, 400 psig @ 100°F
- CRN OF6616.5C
- TFE reinforced stem packing

Part Number	Pipe Size (in.)	Glass O.D. & Length	Wt./100 (lbs.)	Wheel Type
20-304	1/2	5/8 x 12	260	ALUMINUM
20-305	1/2	5/8 x 12	270	COMPOSITION
20-307	3/4	3/4 x 16	345	ALUMINUM
20-308	3/4	3/4 x 16	365	COMPOSITION
20-350*	1/2	5/8 x 12	265	ALUMINUM
20-351*	1/2	5/8 x 12	265	COMPOSITION
20-353*	3/4	3/4 x 16	360	ALUMINUM
20-354*	3/4	3/4 x 16	365	COMPOSITION
25-404	1/2	5/8 x 12	285	ALUMINUM
25-405	1/2	5/8 x 12	285	COMPOSITION
25-407	3/4	3/4 x 16	350	ALUMINUM
25-408	3/4	3/4 x 16	350	COMPOSITION
25-501*	1/2	5/8 x 12	290	ALUMINUM
25-502*	1/2	5/8 x 12	290	COMPOSITION
25-504*	3/4	3/4 x 16	355	ALUMINUM
25-505*	3/4	3/4 x 16	355	COMPOSITION

Note: Service ratings are subject to pressure/temperature ratings of gauge glass and glass gaskets.

* Automatic ball checks

Suffix Key - Applicable for all Water Gauges

SUFFIX KEY

- 00 Standard set includes top & bottom valves, glass and rods
- 01 Top valve only
- 02 Bottom valve only
- 03 Top & Bottom valves only (no glass or rods)
- 10 For special gauges with non-standard glass, rods, and/or gaskets.

WATER GAUGES

20-410 SERIES



SIDE MOUNTED HANDWHEEL WATER GAUGES

Side-mounted handwheels allow water gauge operation in hard-to-reach places; with all the 20 Series design features.

FEATURES

- Ideal for concealed jacketed type boilers
- EPDM standard gauge glass gasket
- Standard 1/4" needle drain valve
- Rated: 125 psig @ 350°F, 300 psig @ 100°F (See note)
- 1-1/4" Extended shank length
- Chrome plate option
- Guard rod glass protection
- CRN OF6616.5C

Part Number	Side	Pipe Size (in.)	Glass O.D. & Length	Wt./100 (lbs.)	Shank Length (in.)	Wheel Type
20-410-00	LH	1/2	5/8 x 12	180	1.25	ALUMINUM

Note: Service ratings are subject to pressure/temperature ratings of gauge glass and glass gaskets.

20-600/20-800 SERIES



BRONZE EXPANSION TANK GAUGES

Bottom shut-off valve allows for glass maintenance without complete drainage.

FEATURES

- Automatic ball check
- EPDM standard gauge glass gasket
- 20-800 models: 1/4" NPT port in upper body for pressure gauge
- Rated: 200 psig @ 400°F, 400 psig @ 100°F (See note)
- Guard rod glass protection
- CRN OF6616.5C

Part Number	Pipe Size (in.)	Glass O.D. & Length	Wt./100 (lbs.)	Wheel Type
20-604-00*	1/2	5/8 x 12	155	ALUMINUM
20-605-00*	1/2	5/8 x 12	175	COMPOSITION
20-804-00*	1/2	5/8 x 12	160	ALUMINUM
20-805-00*	1/2	5/8 x 12	160	COMPOSITION

Note: Service ratings are subject to pressure/temperature ratings of gauge glass and glass gaskets.

Note: Not for use on boiler systems

* Automatic ball checks

COMMERCIAL PRODUCTS CATALOG

20-700/20-710 SERIES



BRONZE EXPANSION TANK GAUGES

Simple liquid level indicator. Available with 3/8" or 1/2" MNPT connections; EPDM gauge glass gaskets and 1/4" drain valve in lower body.

FEATURES

- 20-713 & 20-714 with plug for easy glass replacement
- 1/4" pet cock or Apollo® ball valve optional
- Guard rod glass protection
- Rated: 125 psig @ 350°F, 300 psig @ 100°F (See note)
- CRN OF6616.5C

Part Number	Pipe Size (in.)	Glass O.D. & Length	Wt./100 (lbs.)
20-703-00	3/8	5/8 x 10	120
20-704-00	1/2	5/8 x 12	135
20-713-00	3/8	5/8 x 10	130
20-714-00	1/2	5/8 x 12	145

Note: Service ratings are subject to pressure/temperature ratings of gauge glass and glass gaskets.

Note: Not for use on boiler systems

21 SERIES



BRONZE WATER GAUGES WITH EXTENDED SHANK

Ideal for concealed jacket type boilers.

FEATURES

- 1-3/4" shank length
- 21-100 rated 125 psig @ 350°F, 300 psig @ 100°F
- 21-200 rated 200 psig @ 400°F, 400 psig @ 100°F (See note)
- Equipped with two copper-plated steel guard rods for glass protection
- EPDM glass gasket
- TFE reinforced stem packing
- CRN OF6616.5C

Model Number	Pipe Size (in.)	Glass O.D. & Length	Wt./100 (lbs.)	Wheel Type
21-104	1/2	5/8 x 12	185	ALUMINUM
21-105	1/2	5/8 x 12	197	COMPOSITION
21-150*	1/2	5/8 x 12	195	ALUMINUM
21-151*	1/2	5/8 x 12	207	COMPOSITION
21-204	1/2	5/8 x 12	215	ALUMINUM
21-205	1/2	5/8 x 12	219	COMPOSITION
21-250*	1/2	5/8 x 12	215	ALUMINUM
21-251*	1/2	5/8 x 12	215	COMPOSITION

* Automatic ball checks

Note: Service ratings are subject to pressure/temperature ratings of gauge glass and glass gaskets.

WATER GAUGES

23-400 SERIES



STAINLESS STEEL LIQUID LEVEL GAUGES

Ideal for handling alcohol solvents, acetic acid and ketones. Automatic models conform to ASME requirements; aluminum and composition handwheels.

FEATURES

- PTFE reinforced gauge glass gaskets, stem packings
- Chemical resistant PTFE seat
- 5/16" diameter full-flow, all SS drain ball valves with safety handle
- Four SS guard rods for glass protection
- Rated 500 psig @ 450°F (See note)
- High pressure gauge glass standard
- CRN OF6616.5C
- Automatic check models - conform to ASME power boiler code requirements for automatic water gauges

Part Number	Pipe Size (in.)	Glass O.D. & Length	Wt./100 (lbs.)	Wheel Type
Non-Automatic				
23-401-00	1/2	5/8 x 12	385	ALUMINUM
23-402-00	1/2	5/8 x 12	385	COMPOSITION
23-404-00	3/4	3/4 x 16	450	ALUMINUM
23-405-00	3/4	3/4 x 16	450	COMPOSITION
ASME-Automatic				
23-450-00	1/2	5/8 x 12	390	ALUMINUM
23-451-00	1/2	5/8 x 12	390	COMPOSITION
23-453-00	3/4	3/4 x 16	455	ALUMINUM
23-454-00	3/4	3/4 x 16	455	COMPOSITION

Note: Service ratings are subject to pressure/temperature ratings of gauge glass and glass gaskets.

23-600 SERIES



STAINLESS STEEL EXPANSION TANK GAUGES

Bottom shut-off valve allows for glass maintenance without complete drainage.

FEATURES

- Stainless steel guard rod glass protection
- Rated: 250 psig at 406°F: maximum working pressure (See note)
- Standard PTFE reinforced gauge glass gaskets
- High pressure glass standard
- CRN OF6616.5C

Part Number	Pipe Size (in.)	Glass O.D. & Length	Wt./100 (lbs.)	Wheel Type
23-651-00	1/2	5/8 x 12	225	ALUMINUM
23-654-00	3/4	5/8 x 12	225	COMPOSITION

Note: Service ratings are subject to pressure/temperature ratings of gauge glass and glass gaskets.

Note: Not for use on boiler systems

COMMERCIAL PRODUCTS CATALOG

24-300 SERIES



HEAVY PATTERN BRONZE LIQUID LEVEL GAUGES

Automatic and non-automatic direct reading gauges in shank pipe sizes 1/2" and 3/4".

FEATURES

- Heavy pattern bronze valve body
- Guard rod bracket to accommodate four guard rods
- 250 psig @ 400°F
- 500 psig @ 100°F
- PTFE reinforced gauge glass gasket and stem packing are standard
- Automatic check models - conform to ASME power boiler code requirements for automatic water gauges
- High pressure gauge glass and gaskets are standard
- CRN OF6616.5C
- Bronze ball valve drains are standard

Part Number	Pipe Size (in.)	Glass O.D. & Length	Wt./100 (lbs.)	Wheel Type
Non-Automatic				
24-301-00	1/2	5/8 x 12	425	ALUMINUM
24-302-00	1/2	5/8 x 12	425	COMPOSITION
24-304-00	3/4	3/4 x 16	490	ALUMINUM
24-305-00	3/4	3/4 x 16	490	COMPOSITION
ASME-Automatic				
24-350-00	1/2	5/8 x 12	425	ALUMINUM
24-351-00	1/2	5/8 x 12	425	COMPOSITION
24-353-00	3/4	3/4 x 16	490	ALUMINUM
24-354-00	3/4	3/4 x 16	490	COMPOSITION

Note: Service ratings are subject to pressure/temperature ratings of gauge glass and glass gaskets.

24-600 SERIES



BRONZE CHAIN LEVER WATER GAUGES

Lever on standard 12-foot chain allows operator to open and close valves that would be beyond reach.

FEATURES

- Rated 250 psig @ 400°F, 500 psig @ 100°F (See note)
- Quick operation quarter turn
- ASME automatic ball check option
- 1/4" full-blow ball valve with safety handle
- High pressure glass
- CRN OF6616.5C
- TFE reinforced stem packing
- TFE reinforced glass gasket
- Steel rod glass protection

Part Number	Pipe Size (in.)	Glass O.D. & Length	Wt./100 (lbs.)
24-601-00	1/2	5/8 x 12	515
24-602-00	3/4	3/4 x 16	580
24-651-00*	1/2	5/8 x 12	515
24-652-00*	3/4	3/4 x 16	580

* ASME Automatic ball check model

Note: Service ratings are subject to pressure/temperature ratings of gauge glass and glass gaskets.

WATER GAUGES

25-600 SERIES



POLISHED BRONZE CHAIN LEVER WATER GAUGES

Lever on standard 12-foot chain allows operator to open and close valves that would be beyond reach.

FEATURES

- Quick operation quarter turn
- Service rating: 250 psig @ 400°F, 500 psig @ 100°F (See note)
- EPDM gauge glass gasket
- 1/4" needle drain valve
- 20-600 series un-polished
- Graphite stem packing
- Steel rod glass protection
- CRN OF6616.5C

Part Number	Pipe Size (in.)	Glass O.D. & Length	Wt./100 (lbs.)
25-601-00	1/2	5/8 x 12	335
25-602-00	3/4	3/4 x 16	350
20-601-00 †	1/2	5/8 x 12	370
20-602-00 †	3/4	3/4 x 16	435

Note: Service ratings are subject to pressure/temperature ratings of gauge glass and glass gaskets.

† Un-polished

Water Accessories

GLASS PROTECTOR



TUBULAR GAUGE GLASS PROTECTOR

Reduces risk of injury and damage from glass failure; maximum length: 50"

FEATURES

- Heavy duty brass tube
- No. I-2733* 5/8" Glass Protector
- No. I-2734* 3/4" Glass Protector
- Made to fit most water gauges
- Not available on 23-400, 23-650, 24-300, 24-350, 24-600 models

Note: Water gauge part number and centerline length are required when ordering. Priced according to length and application.

COMMERCIAL PRODUCTS CATALOG

Water Gauge Accessories

TUBULAR GAUGE GLASS PROTECTOR

FEATURES

- Reduces the risk of injury and damage from broken exploding glass.
- Made to fit most water gauges.
- Priced according to length and application.
- Maximum protector length of 50".
- Tubular gauge glass protector not available on the 23-400, 23-650, 24-300, 24-350, and 24-600 series.
- Maximum of 50" length

Give series number and centerline distance "L" when ordering.

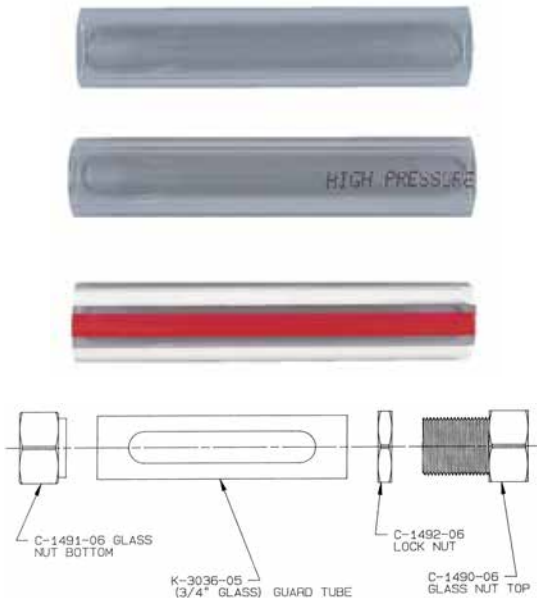

Part Number	Size	Length
I-2733-05	5/8" O.D. glass	Up to 12" long
I-2733-05L	5/8" O.D. glass	12" to 24" long
I-2734-05	3/4" O.D. glass	Up to 16" long
I-2734-05L	3/4" O.D. glass	16" to 24" long

WATER GAUGE REPAIR KITS

Kit	Applications
20-001-01 20-003-01	20-101, 20-102, 20-104, 20-105, 20-150, 20-151, 20-405, 20-406, 20-407, 20-408, 20-410
20-001-02 20-003-02	21-101, 21-102, 21-104, 21-105, 21-150, 21-151, 20-201, 20-202, 20-204, 20-205, 20-250, 20-251, 20-304, 20-305, 20-350, 20-351, 20-604, 20-605, 20-804, 20-805, 21-204, 21-205, 21-250, 21-251, 25-201, 25-202, 25-204, 25-205, 25-404, 25-405, 25-501, 25-502
20-001-03 20-003-03	20-207, 20-208, 20-253, 20-254, 20-307, 20-308, 20-353, 20-354, 25-207, 25-208, 25-407, 25-408, 25-504, 25-505
20-001-04 20-003-04	20-601, 25-601
20-001-05 20-003-05	20-602, 25-602
20-001-06 20-003-06	20-703, 20-704, 20-713, 20-714
20-001-07 20-003-07	23-401, 23-402, 23-450, 23-451
20-001-08 20-003-08	20-405, 20-406, 20-407, 20-408
20-001-09 20-003-09	23-404, 23-405, 23-453, 23-454
20-001-10 20-003-10	23-651, 23-654
20-001-11 20-003-11	24-301, 24-302, 24-350, 24-351, 24-450, 24-451
20-001-12 20-003-12	24-304, 24-305, 24-353, 24-354, 24-453, 24-454
20-001-13 20-003-13	24-601, 24-651, 24-751, 24-851
20-001-14 20-003-14	24-602, 24-652, 24-752, 24-852
20-002-01	20-101, 20-102, 20-104, 20-105, 20-150, 20-151, 20-201, 20-202, 20-204, 20-205, 20-250, 20-251, 20-304, 20-305, 20-350, 20-351, 20-405, 20-406, 20-407, 20-408, 20-410, 20-601, 20-604, 20-605, 20-703, 20-704, 20-713, 20-714, 20-804, 20-805, 20-207, 20-208, 20-253, 20-254, 20-307, 20-308, 20-353, 20-354, 25-207, 25-208, 25-407, 25-408, 25-504, 25-505, 20-602, 25-602
20-002-02	23-401, 23-402, 23-450, 23-451, 24-301, 24-302, 24-350, 24-351, 24-450, 24-451, 24-601, 24-651, 24-751, 24-851
20-002-03	23-404, 23-405, 23-453, 23-454, 24-304, 24-305, 24-353, 24-354, 24-453, 24-454, 24-602, 24-652, 24-752, 24-852

Hypalon®, Teflon® and Viton® are registered trademarks of DuPont.

The standard repair kits contain glass packing, stem packing, friction washers, seat washers, and drain washer applicable to the particular valve. Three types of glass packing, EPDM rubber, Hypalon®, and Virgin Teflon®, are included in the standard repair kit. For oil related service, Fluorelastomer (Viton®) glass gasket sets are available. For severe applications, graphite glass gaskets and stem packing sets are available for each model.

REPAIR KIT SELECTION INSTRUCTIONS

It is helpful to determine the following information when ordering a repair kit.

- Model number (if not available describe gauge, i.e. material, # guard rods, NPT size, etc.)
- Glass O.D. and type
- Handle type
- Service media, temperature, and pressure

If you know the model number just refer to the "Repair Kit Applications" chart to select kit number for your valve. To order the standard kit, or Viton®, or graphite gaskets, assemble the ordering matrix for the desired kit number.

If you are unable to determine model number please determine the above information and call customer service for assistance.

For replacement glass please determine the above information in addition to the "L" dimension and call customer service. "L" dimension (center to center height of water gauge inlets).



Air Cocks
Gas Cocks
Hose Bibbs
Boiler Drains

PLUMBING SPECIALTIES



PLUMBING SPECIALTIES

Air Cocks
Gas Cocks
Hose Bibbs
Boiler Drains



PLUMBING SPECIALTIES

Compression Gauge Cocks

26-100/26-300 SERIES



26-300

COMPRESSION GAUGE COCKS

For draining expansion tanks, other liquid storage vessels. For condensate only. Standard finish is Satin Brass.

FEATURES

- 26-100: rated up to 125 psig
- 26-300: soft metal seat/stuffing box rated up to 250 psig at 400°F
- 26-310: stainless steel ball seat/stuffing box rated up to 250 psig at 400°F
- 26-700: TFE seat, rated up to 250 psig at 400°F

Series Number	Pipe Size (in.)	Wt./100 (lbs.)	Wheel Type
26-101-01	3/8	25.0	ALUMINUM
26-102-01	3/8	30.0	COMPOSITION
26-104-01	1/2	28.3	ALUMINUM
26-105-01	1/2	30.0	COMPOSITION
26-301-01	3/8	39.0	ALUMINUM
26-302-01	3/8	40.0	COMPOSITION
26-304-01	1/2	40.0	ALUMINUM
26-305-01	1/2	44.0	COMPOSITION
26-307-01	3/4	49.0	ALUMINUM
26-308-01	3/4	51.7	COMPOSITION
26-311-01	3/8	39.0	ALUMINUM
26-312-01	3/8	42.0	COMPOSITION
26-314-01	1/2	40.0	ALUMINUM
26-315-01	1/2	44.0	COMPOSITION
26-317-01	3/4	50.0	ALUMINUM
26-318-01	3/4	50.0	COMPOSITION
26-704-01	1/2	78.0	ALUMINUM
26-705-01	1/2	82.0	COMPOSITION
26-707-01	3/4	88.0	ALUMINUM
26-708-01	3/4	105.0	COMPOSITION

*26-100 series is not available with packing nut

Specify the following suffix for finish: Polished Brass -28 (example: 26-304-28)

Compression Cock

26-500 SERIES



LEVER OPERATED COMPRESSION COCK

For draining expansion tanks or other liquid storage vessels where the drain port is beyond reach. Spring loaded lever provides positive closure to 250 psig at 300°F.

FEATURES

- Bronze body B584 UNS C84400
- Stainless steel closure spring
- PTFE soft seat
- Graphite stem packing
- Zinc plated "S" hook on lever
- Optional 6 foot chain
- Rated up to 250 psig

Series Number	Pipe Size (in.)	Wt./100 (lbs.)	
26-504-01	1/2	110	
26-504-02	1/2	112	6' chain
26-507-01	3/4	115	
26-507-02	3/4	117	6' chain

COMMERCIAL PRODUCTS CATALOG

Steam Gauge Siphon

27-400 SERIES

STEAM GAUGE SIPHON

For pressure gauge protection .

FEATURES

- Heavy gauge seamless brass tubing
- Brass (-01)
- Chrome plate (-03)
- 27-401 is 180° loop, 27-402 is 90° loop
- Service rating: 250 psig saturated steam, 400 psig at 100°F



27-401



27-402

Series Number	Pipe Size (in.)	Wt./100 (lbs.)
27-401-01	1/4	44.0
27-402-01	1/4	40.0

PLUMBING SPECIALTIES

Air Cocks

41 SERIES









AIR COCKS (FOR AIR USE ONLY)







An economical way to shut-off air lines. Standard spring bottom (-01) with 5/32" port are tested at 80 psig. Optional nut bottom (-04) with 1/8" port are suitable for pressures to 200 psig. Various handle configurations available.

FEATURES

- Standard spring bottom (5/32" port) air cocks tested at 80 psi
- Optional nut bottom (1/8" port) suitable to 200 psig
- Standard Satin Brass finish
- Maximum temperature is 500° F

Type	Satin Brass
Standard Spring Bottom	-01
Nut Bottom	-04



	Series Number	Pipe Size (in.)	Wt./100 (lbs.)
	TEE HANDLE ROUND SHOULDER		
	41-060	1/8	12.8
	41-070	1/4	13.0
	TEE HANDLE HEXAGON SHOULDER		
	41-080	3/8	17.0
	41-090	1/2	20.0
	LEVER HANDLE ROUND SHOULDER		
	41-120	1/8	13.1
	41-130	1/4	14.2
	LEVER HANDLE HEXAGON SHOULDER		
	41-140	3/8	17.0
	41-150	1/2	22.9
	TEE HANDLE DOUBLE MALE THREAD		
	41-180	1/8	14.0
	41-190	1/4	17.9
	41-203	3/8	20.0
	41-210	1/2	33.1
	LEVER HANDLE DOUBLE MALE THREAD		
	41-220	1/8	14.0
	41-230	1/4	18.5
	41-240	3/8	19.1
	41-251	1/2	31.3
	TEE HANDLE BIBB NOSE		
	41-260	1/8	14.5
	41-270	1/4	16.3
	41-280	3/8	33.3
	41-330	1/2	36.0
	LEVER HANDLE BIBB NOSE		
	41-290	1/8	16.5
	41-300	1/4	15.0
	41-310	3/8	32.1
	41-320	1/2	36.0



	Series Number	Pipe Size (in.)	Wt./100 (lbs.)
	TEE HANDLE DOUBLE FEMALE		
	41-370	1/8	13.0
	41-380	1/4	14.0
	41-390	3/8	26.0
	41-391	1/2	27.0
	TEE HANDLE MALE & FEMALE		
	41-400	1/8	13.0
	41-410	1/4	14.0
	41-420	3/8	21.0
	41-421	1/2	26.0
	LEVER HANDLE DOUBLE FEMALE		
	41-430	1/8	14.8
	41-440	1/4	13.0
	41-450	3/8	23.0
	41-451	1/2	27.0
	LEVER HANDLE MALE & FEMALE		
	41-460	1/8	15.2
	41-470	1/4	15.0
	41-480	3/8	23.0
	41-481	1/2	27.0
	TEE HANDLE MALE & FEMALE HEX SHOULDER		
	41-490	1/8	17.0
	41-500	1/4	15.0
	41-510	3/8	23.0
	41-511	1/2	25.0
	LEVER HANDLE MALE & FEMALE HEX SHOULDER		
	41-520	1/8	14.0
	41-530	1/4	15.0
	41-540	3/8	22.1
	41-541	1/2	27.0

COMMERCIAL PRODUCTS CATALOG

Air Cocks

41 SERIES (CONT.)

	Series Number	Size (in.)	Wt./100 (lbs.)
	TEE HANDLE DOUBLE FEMALE HEX SHOULDER		
	41-550	1/8	17.0
	41-560	1/4	17.0
	41-570	3/8	25.0
	41-571	1/2	28.3
	LEVER HANDLE DOUBLE FEMALE HEX SHOULDER		
	41-580	1/8	15.0
	41-590	1/4	18.2
	41-600	3/8	24.0
	41-601	1/2	28.8

	Series Number	Size (in.)	Wt./100 (lbs.)
	TEE HANDLE STRAIGHT NOSE HEX SHOULDER		
	41-630	1/8	15.7
	41-640	1/4	15.0
	LEVER HANDLE STRAIGHT NOSE HEX SHOULDER		
	41-650	1/8	14.0
	41-660	1/4	15.0

Air Cocks

41 SERIES HEAVY PATTERN



HEAVY AND EXTRA HEAVY PATTERN AIR AND STEAM COCKS

Heavy and extra heavy patterns for higher pressure applications.

FEATURES

- Satin brass finish
- Spring Bottom (-01) is tested at 100psi
- Rated for air pressure up to 250 psig with nut version
- Extra heavy pattern rated for 150 SWP - nut bottom only

Type	Suffix Code
Spring Bottom (Standard)	-01
Nut Bottom	-04

Series Number	Size (in.)	Wt./100 (lbs.)
HEAVY PATTERN TEE HANDLE DOUBLE FEMALE		
41-102-01	1/4	28.00
LEVER HANDLE DOUBLE FEMALE		
41-103-01	1/4	27.00
EXTRA HEAVY PATTERN TEE HANDLE DOUBLE FEMALE		
41-200-01	1/8	32.00
41-202-01	1/4	32.00
TEE HANDLE DOUBLE FEMALE HEXAGON SHOULDER		
41-222-01	1/4	38.00
TEE HANDLE MALE AND FEMALE		
41-250-01	1/4	20.00

PLUMBING SPECIALTIES

Drain Cocks

42-100 SERIES



DRAIN COCKS

Cast brass construction; rated for 25 psig.

FEATURES

- Sizes: 1/8", 1/4", 3/8" and 1/2"
- Cast brass finish
- Standard spring bottom (suffix code -01)

Series Number	Size (in.)	Orifice (in.)	Wt./100 (lbs.)
42-101-01	1/8	3/16	20.4
42-102-01	1/4	1/4	15.0
42-103-01	3/8	3/8	35.0
42-104-01	1/2	3/8	38.0

Steam Gauge Cocks

43-100 SERIES



STEAM GAUGE COCKS

Female fitting with male union for easy installation.

FEATURES

- Satin brass finish
- Rated 100 SWP for standard bottom, 150 SWP for nut version

Type	Suffix Code
Standard Spring Bottom	-01
Nut Bottom	-04

Series Number	Description	Size (in.)	Wt./100 (lbs.)
43-101-01	100 SWP	1/4 FNPT	45
43-101-04	150 SWP	1/4 FNPT	45

Air Cocks

44-100 SERIES



HOSE END COCKS

Interior diameter hose sizes: 3/8" to 7/16"

FEATURES

- 3/16" port; rated 25 psig
- Satin brass finish

Series Number	Size (in.)	Wt./100 (lbs.)
44-101-01	1/8	19
44-102-01	1/4	22
44-103-01	3/8	23
44-104-01	1/2	25

COMMERCIAL PRODUCTS CATALOG

Gas Cocks

GCB (50) SERIES



MANUAL MAIN CONTROL VALVES

CSA design certified for 1/2 psig and temperatures from 32° to 125°F. Complies to ANSI Z 21.15, CSA 9.1

FEATURES

- Factory tested 100% at 10 psig
- Bronze construction, stainless steel springs
- Capacities to 7.8 million BTU/hour
- Equal female inlet/outlet
- Bosses on both sides are drilled and tapped. Only one side is plugged

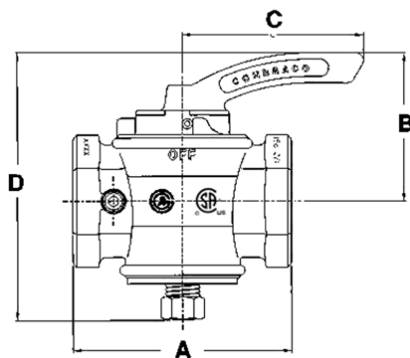

Series Number	Size (in.)	BTU/hr.	Wt./100 (lbs.)	Dimensions			
				A	B	C	D
50-203*	1/2	800,000	88	2.50	1.44	1.72	2.75
50-303	3/4	1,310,000	156	2.94	1.69	2.06	3.50
50-403	1	2,100,000	197	3.94	2.19	2.87	3.87
50-503	1-1/4	3,250,000	300	3.66	2.75	3.16	4.69
50-603	1-1/2	3,700,000	478	4.37	3.31	3.50	5.75
50-703	2	7,300,000	845	5.44	3.72	4.50	6.75
50-803	2-1/2	7,800,000	1000	5.87	3.72	4.50	6.75

* 1/2" size is not CSA certified

HANDLE SUFFIX POSITION

Size Pilot (in.)	W	X	Y	Z
1/8 NPT	01	02	03	04
1/4 NPT	05	06	07	08

All main burner valves furnished with 1/8" NPT pilot tapping. Valves 1" and larger can be furnished with 1/4" NPT pilot tapping.

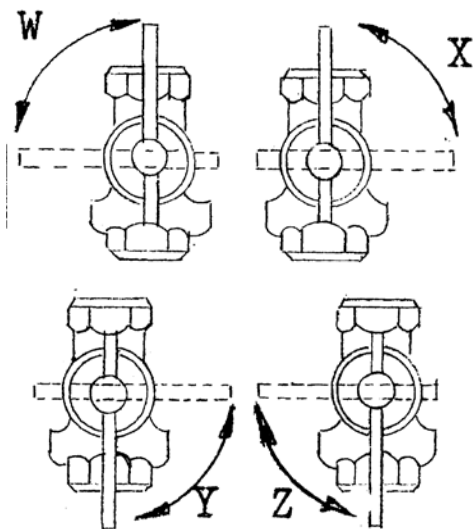

PLUMBING SPECIALTIES

Gas Cocks

GC (51) SERIES



GAS SERVICE COCKS

Tee or lever handle cocks; CSA design certified. In sizes 1/4" to 3/4".

FEATURES

- Capacities: 117,000 to 749,000 BTU/hour
- Certified to ANSI Z21.15 and CSA 9.1 (1/2 psig at temperatures from 32° F to 125°F)
- Accepted for use in City of New York Department of Buildings MEA 45-90-M

Series Number	Pipe Size (in.)	Wt./100 (lbs.)	Capacity (BTU/hr.)
T-HANDLE W/STOP			
51-103-01	1/4	35	117,000
51-104-01	3/8	47	274,600
51-105-01	1/2	54	274,000
51-106-01	3/4	83	749,000
LEVER HANDLE W/STOP			
51-107-01	3/8	50	274,600
51-108-01	1/2	56	274,600
51-109-01	3/4	87	749,000

Gas Cocks

GC2 (52) SERIES



GAS SERVICE COCKS

Available with tee head, flat head, square head or lever head in sizes from 1/4" to 1". Wrench operated and tested at 125 psig.

FEATURES

- High pressure rating
- Capacities: 117,000 to 749,000 BTU/hour
- Accepted for use in City of New York Department of Buildings MEA 45-90-M
- Max. temperature: 500°F

Series Number	Size (in.)	Wt./100 (lbs.)	Series Number	Size (in.)	Wt./100 (lbs.)
T-HEAD			SQUARE HEAD		
52-101-01	1/4	32.0	52-301-01	1/4	31.0
52-102-01	3/8	29.0	52-302-01	3/8	28.0
52-103-01	1/2	45.0	52-303-01	1/2	43.0
52-104-01	3/4	65.8	52-304-01	3/4	62.7
52-105-01	1	92.9	52-305-01	1	90.0
FLAT HEAD			LEVER HEAD		
52-201-01	1/4	30.0	52-401-01	1/4	34.3
52-202-01	3/8	28.0	52-402-01	3/8	31.0
52-203-01	1/2	43.0	52-403-01	1/2	46.0
52-204-01	3/4	57.0	52-404-01	3/4	66.7
52-205-01	1	90.6	52-405-01	1	97.0

COMMERCIAL PRODUCTS CATALOG

Gas Cocks

GC3 (53) SERIES



GAS COCKS

Available in male and female sizes: 1/8", 1/4" and 3/8".

FEATURES

- Capacities: 117,000 to 749,000 BTU/hour
- 200 CWP
- Certified to ANSI Z21.15 and CSA 9.1 (1/2 psig at temperatures from 32° F to 125°F)
- Accepted for use in City of New York Department of Buildings MEA 45-90-M

Series Number	Male Size (in.)	Female Size (in.)	Wt./100 (lbs.)
53-299-01*	1/8	1/8	14.0
53-300-01*	1/4	1/4	18.5
53-301-01	3/8	3/8	45.0

* Design certified by CSA to meet ANSI Z21.15.CSA 9.1 pressure requirements of 1/2 psig

Gas Cocks

GCA (54) SERIES



54-100



54-200



GAS HOSE COCKS & APPLIANCE CONNECTOR VALVES

FEATURES

- CSA design certified bronze gas valves with 56,500 BTU/hour capacity.
- Certified to ANSI Z21.15 and CSA 9.1 (1/2 psi at 32° F to 125°F)

Series Number	Pipe Size (in.)	Outlet (in.)	Wt./100 (lbs.)
54-101-01	3/8	1/8 MNPT	41.0
54-102-01	1/2	1/8 MNPT	34.8
54-103-01	3/4	1/8 MNPT	40.0

Series Number	Pipe Size (in.)	Outlet (in.)	Wt./100 (lbs.)
54-201-01	3/8	3/8 SAE	36.0
54-202-01	1/2	3/8 SAE	33.4
54-203-01	1/2	1/2 SAE	35.0
54-204-01	3/4	1/2 SAE	45.1
54-206-01	3/4	5/8 SAE	50.0
54-207-01	1/2	5/8 SAE	57.0
54-208-01	3/4	3/8 SAE	44.0
54-209-01	3/4	1/2 MNPT	44.0

PLUMBING SPECIALTIES

Gas Cocks

GCR (55) SERIES



GAS COCK WITH THROTTLE ADJUSTMENT DESIGN CERTIFIED BY CSA

FEATURES

- Certified to ANSI Z21.15 and CSA 9.1 (1/2 psig at 32° F to 125°F)
- Thread size: 1/4" male x 1/4" female

Series Number	Size (in.)	Wt./100 (lbs.)
55-302-01	1/4 M x 1/4 F	33

Gas Cocks

GCP (56) SERIES





PILOT COCKS

Wide variety of CSA design certified pilot cocks.



FEATURES

- Certified to ANSI Z21.15 and CSA 9.1 (1/2 psig at 32° F to 125°F)

	Model Number	Size (in.)	Wt./100 (lbs.)
	56-111-01	1/8 NPT x 1/4 Tube Plain	15.0
	56-112-01	1/8 NPT x 1/4 Tube Throttle Adjust.	14.0
	56-221-01	1/8 NPT x 1/8 FNPT Plain	16.1
	56-222-01	1/8 NPT x 1/8 FNPT Throttle Adjust.	16.1
	56-601-01	1/8 NPT x 1/4 Tube Right Hand	17.0
	56-602-01	1/8 NPT x 1/4 Tube RH Throttle Adjust	17.0
	56-603-01	1/8 NPT x 1/4 Tube Left Hand.	17.0
	56-604-01	1/8 NPT x 1/4 Tube LH Throttle Adjust.	17.0

COMMERCIAL PRODUCTS CATALOG

Compression Bibb Faucet

HB (35-200) SERIES



COMPRESSION BIBB FAUCET

Features heavy pattern with large flow path.

FEATURES

- Solid bronze construction
- Both models have 3/4" hose connection
- Aluminum handwheel
- Made in USA

Series Number	Pipe Size (in.)	Wt./100 (lbs.)
35-201-01	1/2	58.3
35-202-01	3/4	57.0

Water Heater Drain Valves

BD90 (31-200/31-500) SERIES



90° DRAIN VALVES

For deluxe water heaters and low pressure boilers.

FEATURES

- Max. rated pressure: 200 psig
- Max. rated temperature: 250°F
- Red aluminum wheel handle
- Optional plain finish handle (-04P)
- 31-200 Series heavy pattern, 3/4" MNPT inlet
- 31-500 Series standard pattern, 1/2" MNPT inlet with I.D. of NPT thread machined for 1/2" copper pipe
- Made in USA

Series Number	LF Series Number	Wt./100 (lbs.)	Shank Length (in.)	Inlet (in.)
31-202-04	31LF-202-04	43.00	5/8	3/4 MNPT
31-212-04	31LF-212-04	46.50	15/16	3/4 MNPT
31-501-04	31LF-501-04	31.00	5/8	1/2 MNPT/1/2 Sweat

Water Heater Drain Valves

BDT (31-400) SERIES



COMBINATION TEE & DRAIN VALVES

Permits supplying and draining of water through a single tank tapping and meets CSA requirements.

FEATURES

- All cast bronze bodies
- Aluminum handwheel
- No handle: Screwdriver slot stem option
- Max. rated pressure: 200 psig
- Max. rated temperature: 250° F
- 3/4" FNPT inlet x 3/4" male hose end x 3/4" FNPT side outlet
- Made in USA

Series Number	LF Series Number	Wt./100 (lbs.)	Handle
31-401-04	31LF-401-04	62.00	Aluminum Wheel - Red
31-401-04P	31LF-401-04P	62.00	Aluminum Wheel - Plain
31-401-13	31LF-401-13	62.00	Slotted Stem

PLUMBING SPECIALTIES

Water Heater Drain Valves

BD (31-600/31-700) SERIES



31-600
Male NPT



31-700
Female NPT

ANGLED BODY WATER HEATER DRAIN VALVES

All drains are equipped with Conbraco packing seal assuring easy turning stem and leak proof drain. Various shank lengths available. Meets CSA requirements.

FEATURES

- All cast bronze bodies
- Max. rated pressure: 200 psig
- Max. rated temperature: 250° F
- 31-600: 3/4" MNPT inlet
- 31-700: 1/2" or 3/4" FNPT inlet
- Made in USA

HANDLE SUFFIX KEY

-04	Aluminum Wheel - Red
-04P	Aluminum Wheel - Plain
-13	Slotted Stem

* Not all variations available in all sizes. Contact customer service.

Series Number	Shank Length (in.)	Inlet (in.)	Wt./100 (lbs.)
31-600	5/8"	3/4" MNPT	27.3
31-601	3/4"	3/4" MNPT	36.0
31-602	1"	3/4" MNPT	35.0
31-604	1-1/4"	3/4" MNPT	43.0
31-606	1-1/2"	3/4" MNPT	49.5
31-607	1-3/4"	3/4" MNPT	48.0
31-608	2"	3/4" MNPT	52.0
31-609	2-1/4"	3/4" MNPT	52.0
31-610	2-1/2"	3/4" MNPT	57.2
31-611	2-3/4"	3/4" MNPT	60.0
31-612	3"	3/4" MNPT	66.3
31-700		1/2" FNPT	39.0
31-701		3/4" FNPT	37.0

Water Heater Drain Valves

BD (35-300) SERIES

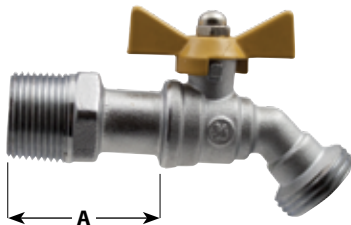

APOLLO INTERNATIONAL™ BALL VALVE BIBB FAUCET

Features heavy pattern with large opening. Ideal for boiler and water heater drains, general liquid dispensing and drainage. The new 45° spout design allows for easier hose connection access.

FEATURES

- Chrome plated finish; sizes 1/2" and 3/4"
- Pressure rating 200 psig liquid
- Maximum temperature 250°F

Series Number	Size (in.)	A (in.)	Inlet (in.)	Outlet (in.)	Wt./100 (lbs.)
35-301-03	1/2	1-1/2	1/2 sweat/thrd connector	0.75-11.5 NHR hose	38.4
35-302-03	3/4	1-3/4	3/4 thrd connector	0.75-11.5 NHR hose	44.5

WARRANTY INFORMATION

WARRANTY AND LIMITATIONS OF LIABILITY

Conbraco Industries, Inc. warrants, to its initial purchaser only, that its products which are delivered to this initial purchaser will be of the kind described in the order or price list and will be free of defects in workmanship or material for a period of **FIVE** years from the date of delivery to you, our initial purchaser. This warranty applies to Apollo brand product with "Made in the USA" markings only.

Should any failure to conform to this warranty appear within **FIVE** years after the date of the initial delivery to our initial purchaser, Conbraco will, upon written notification thereof and substantiation that the goods have been stored, installed, maintained and operated in accordance with Conbraco's recommendations and standard industry practice, correct such defects by suitable repair or replacement at Conbraco's own expense.

APOLLO INTERNATIONAL PRODUCTS: Conbraco Industries, Inc. warrants its International products, to its initial purchaser only, that its international products which are delivered to this initial purchaser will be of the kind described in the order or price list and will be free of defects in workmanship or material for a period of **TWO** years from the date of delivery to you, our initial purchaser.

THIS WARRANTY IS EXCLUSIVE AND IS IN LIEU OF ANY IMPLIED WARRANTY OF MERCHANTABILITY, FITNESS FOR A PARTICULAR PURPOSE OR OTHER WARRANTY OF QUALITY, WHETHER EXPRESSED OR IMPLIED, EXCEPT THE WARRANTY OF TITLE AND AGAINST PATENT INFRINGEMENT. Correction of non-conformities, in the manner and for the period of time provided above, shall constitute fulfillment of all liabilities of Conbraco to our initial purchaser, with respect to the goods, whether based on contract, negligence, strict tort or otherwise. It is the intention of Conbraco Industries, Inc. that no warranty of any kind, whether expressed or implied shall pass through our initial purchaser to any other person or corporation.

LIMITATION OF LIABILITY: Conbraco Industries, inc. SHALL NOT UNDER ANY CIRCUMSTANCES BE LIABLE FOR SPECIAL OR CONSEQUENTIAL DAMAGES SUCH AS, BUT NOT LIMITED TO, DAMAGES OR TO LOSS OF OTHER PROPERTY OR EQUIPMENT, LOSS OF PROFITS OR REVENUE, COST OF CAPITAL, COST OF PURCHASED OR REPLACEMENT GOODS, OR CLAIMS OF CUSTOMERS OF OUR INITIAL PURCHASER. THE REMEDIES OF OUR INITIAL PURCHASER, AND ALL OTHERS, SET FORTH HEREIN, ARE EXCLUSIVE, AND THE LIABILITY OF CONBRACO WITH RESPECT TO SAME SHALL NOT, EXCEPT AS EXPRESSLY PROVIDED HEREIN, EXCEED THE PRICE OF THE GOODS UPON WHICH SUCH LIABILITY IS BASED.

* It is the end user's responsibility to confirm that items intended for use satisfy local codes and standards.



TERMS AND CONDITION OF SALE

- Payment: 2% 10th prox. Net 30 days.
- All prices F.O.B. shipping point with freight allowed on shipments of 750 pounds and/or \$5,000 net minimum to all shipping points within the United States excluding Alaska and Hawaii. No freight allowed on Air Freight or Parcel Post shipments. Claims for shortages must be made within 10 days of receipt of material. Our responsibility ends when a receipt is furnished us by the carrier.
- No Invoice Rendered For Less Than \$50.00.
- No freight will be allowed on Air Freight, Air Express, Parcel Post or U.P.S. shipments.
- All Conbraco products may be combined to make sufficient weight for full freight allowance.
- Phone order quoted prices are subject to correction. Prices and designs are subject to change without notice.
- Orders for material or special design or specification are made to customer's order and are not subject to cancellation or return.
- All goods returned to us will not be accepted unless a full explanation has been made and our written authorized permission obtained in advance. All goods returned – if accepted – will be credited at invoice price, less 30% for service and rehandling charges, plus shipping expenses.
- We reserve the right to adjust orders to box quantities.

APOLLO VALVES & ELKHART PRODUCTS SALES MANAGERS & INTERNATIONAL SALES MANAGERS

	AREAS COVERED	EMAIL	PHONE	FAX
DIRECTOR OF INDUSTRIAL SALES				
Mike Green	Industrial	mike.green@conbraco.com	704-841-6039	704-841-6021
REGIONAL SALES MANAGERS – INDUSTRIAL				
Dave Eck	Northeast	david.eck@conbraco.com	302-268-4411	
JR Fortenberry	Mountain States	jr.fortenberry@conbraco.com	480-824-8288	
Ken Griffin	Southeast	ken.griffin@conbraco.com	704-621-9296	704-841-6021
Jim Todman	Canada	jim.todman@conbraco.com	905-407-8385	905-761-6666
Skip Wilson	West	skip.wilson@conbraco.com	760-518-2222	775-854-5722
COMMERCIAL SALES MANAGERS – APOLLO VALVES & ELKHART PRODUCTS				
Kevin Ashworth	National Project Mgr. - Commercial	kevin.ashworth@conbraco.com	757-272-6200	
Brian Blalock	Director of National Sales - Valves	brian.blalock@conbraco.com	704-614-3744	704-841-6021
Brian Fiorisi	Project Mgr. - Pex & Fittings	brian.fiorisi@conbraco.com	574-524-6675	
Todd Green	National Sales Mgr. - APOLLOXPRESS® - West	todd.green@conbraco.com	501-920-2029	
John Hembree	Sales Mgr. - Push Product	john.hembree@conbraco.com	678-618-8471	
Sean Perry	Sales Mgr. - Fire Protection & Waterworks	sean.perry@conbraco.com	704-641-9167	
Robert Purchia	National Sales Mgr. - APOLLOXPRESS® - East	robert.purchia@conbraco.com	704-960-3532	
Cary Wiley	Sales Mgr. - Fire Protection & Waterworks	cary.wiley@conbraco.com	678-642-3356	
REGIONAL SALES MANAGERS – COMMERCIAL				
Keith Baca	Southeastern	keith.baca@conbraco.com	615-630-3892	
Steve Brown	Northwestern	steve.brown@conbraco.com	425-985-5095	253-862-3548
Andy Fretz	Canada	andy.fretz@conbraco.com	647-281-3161	905-761-6666
Ben Lauletta	Northeastern	ben.lauletta@conbraco.com	518-795-4629	
Nick Shelley	Central	nick.shelley@conbraco.com	214-790-4157	
Jeremy Swirck	Southwestern	jeremy.swirck@conbraco.com	714-296-5346	
LASCO FITTINGS REGIONAL SALES MANAGERS – IRRIGATION				
David Beyer	Northeast	dbeyer@lascofittings.com	561-718-9379	
Don Caver	Central	dcaver@lascofittings.com	469-628-4918	
Ben Freeman	Southeast	bfreeman@lascofittings.com	205-919-4944	
Bryan Jackman	West	bjackman@lascofittings.com	714-673-5875	
Jimmy White	National Sales Manager	jwhite@lascofittings.com	731-234-2372	
Rick Williamson	Eastern Specifications Manager	rwilliamson@lascofittings.com	386-451-2307	
INTERNATIONAL SALES REPS				
Jose Arias	Mexico	jose.arias@conbraco.com	1-956-631-4542	1-956-631-4681
Erick de Miranda	Asia & the Caribbean	erick.demiranda@conbraco.com	1-720-383-8757	
JR Jefferson	Central & South America	jr.jefferson@conbraco.com	1-832-220-3783	
Luke Liu	China	luke.liu@conbraco.com	86-411-869-02498	
Brencliff Group	Australia, New Zealand	petermcl@brencliff.com	61 477 223110	
Pegler Yorkshire	United Kingdom	adrian.byrne@conbraco.com	44-7740-449858	
Pegler Yorkshire Mid East	Middle East/India	peter.pydubai@gmail.com	971-4-454-2353	971-4-454-2352
	Europe/Africa/Israel	customersupport@conbraco.com	1-704-841-6000	1-704-841-6021

current as of 5/28/14



For additional information, submittal sheets and manuals, visit www.apollovalves.com

Customer Service (704) 841-6000



SALES & CUSTOMER SERVICE:

Phone: (704) 841-6000 Fax: (704) 841-6020

www.apollovalves.com

APOLLO VALVES COMMERCIAL REPS

	AGENCY	AREAS COVERED	EMAIL	PHONE	FAX
SOUTHEAST	SOUTHEAST REGION REPS				
	Mid South Marketing, Inc.	VA/MD/Washington DC/WV-East	michael.uecker@msmsales1.com	804-213-3801	804-213-3802
	Midwest Spec	Southern OH, KY	rvsales@mwspec.com	800-755-7732	513-353-1589
	Pro Marketing, Inc.	NC/SC/TN-East	sales@promarketinginc.net	864-578-4334	864-578-4889
	Spirit Group	FL (except Panhandle)	info@spiritgroupinc.com	407-291-6035	407-299-0378
	Tim Morales & Associates, Inc.	AL/LA/FL Panhandle	sales@timmorales.com	251-602-8333	251-602-8339
	White Wolf Group	GA	info@whitewolfgroupinc.com	800-401-4870	888-908-9372
NORTHEAST	NORTHEAST REGION REPS				
	Conroy & Griese Sales, Inc.	NY-East/NJ-North	iezzi52@aol.com	856-429-2660	856-429-2230
	Layden Company	NY-Upstate/PA-East/DE/NJ-South	joejr@laydencompany.com	610-363-6657	877-529-3361
	Midwest Spec	Northern OH, Western PA, WV	glsales@mwspec.com	330-538-0406	330-538-0410
	Urell, Inc.	MA/New England States	apollo@urell.com	617-923-9500	617-926-9414
	V.E. Sales Co., Inc.	MI (Except Upper Peninsula)	tomv@vesalesinc.com	586-774-7760	586-774-1490
CENTRAL	CENTRAL REGION REPS				
	Big Rivers Marketing LLC	KS except Northeast	trosner@bigriversllc.com	800-727-3057	816-214-9017
	New Tech Marketing	Northern-IL/WI-East/IN/MI-UP/IA-River Counties	sales@new-techmarketing.com	630-378-4300	630-378-0343
	New Tech Marketing	MO/Southern IL/Northeast Kansas	ntm112@aol.com	618-394-0329	618-394-0427
	NSC Marketing Group Inc.	OK	nsc_tulsa@sbcglobal.net	918-627-5340	918-664-1408
	PEPCO Sales & Marketing	TX	is@pepcosales.com	972-823-8700	972-823-8717
	Southern Marketing Group	MS/TN-West/AR/Bowie Cty.-TX	SMG49@bellsouth.net	901-547-0042	901-547-0035
NORTHWEST	NORTHWEST REGION REPS				
	FourMation Sales	MN/ND/SD/WI-West	ryan@fourmationsales.com	763-420-6900	763-420-6993
	Gordon & Associates	WA, OR, AK, Northern counties ID, HI	laura@gordonandassoc.com	360-566-1470	360-566-1478
	Marshall-Rodeno Heartland	NE/IA (Except River Counties)	dnaylor@marshallrodeno.com	303-575-6701	303-575-6706
SOUTHWEST	SOUTHWEST REGION REPS				
	Elmco Duddy	CA - South	tduddy@elmcoduddy.com	626-333-9942	626-855-4811
	HC Fletcher	CA - North	apollosales@hcfletcher.com	800-432-7047	949-660-9072
	Marshall-Rodeno Associated	ID-SE, NV-NE, UT, CO, MT, NM	dnaylor@marshallrodeno.com	303-575-6701	303-575-6706
	Southwest Valves	CA (Waterworks)	c.burell@southwestvalve.com	559-261-2703	559-261-2711
	Southwestern Industrial Sales Co.	AZ, Nevada (except NE)	sales@sw-ind.com	480-458-5838	480-458-5843
CANADA	CANADA REPS				
	Barclay Sales Ltd.	British Columbia	jblair@barclaysales.com	604-945-1010	604-945-3030
	Conbraco Industries, Canada	178 Pennsylvania Ave., Unit 1, Concord, Ontario L4K 4B1	conbraco.canada@conbraco.com	905-761-6161	905-761-6666
	D & M Mechanical Sales	Ontario/East	don@dandmsales.ca	613-384-7084	613-384-3407
	Dynamic Agencies, Ltd.	Saskatchewan	doug.dynamicage@sasktel.net	306-343-1901	306-343-1901
	J. Levandier Sales, Inc.	NS, NB, PE & NL	vickie@jlevandiersales.com	506-858-1615	506-858-1084
	Kern Industries, Ltd.	Alberta-North	colin@kernind.com	780-451-2056	780-454-6687
	Kern Industries Calgary, Ltd.	Alberta-South	kerncalgary@telus.net	403-730-7791	403-239-8179
	Key to the North Sales Agency, Inc.	Ontario-North	office@keytothenorth.net	705-867-1401	
	Task Controls, Inc.	Ontario-South	infotoronto@taskcontrols.com	416-291-3004	416-754-3481
	Tom Beggs Agencies Ltd.	Manitoba/NW Ontario	tba@mymts.net	204-953-1900	204-774-6915
	Ventes Techniques Nimatec, Inc.	Quebec	nimatec@nimatec.com	450-691-9427	450-691-4949
IRRIGATION ONLY	IRRIGATION REPS				
	Active Sales Northwest, Inc.	OR, WA, Western ID	stevek@activesalesnw.com	541-726-0320	541-726-1148
	Biz Sales Company	OH, KY, MI, IN, parts of WI	dzavelson@bizpvf.com	216-595-2888	216-595-2899
	Blake Bradbury	TX - Southern, LA, MS - Southern	bbradbury@lascofittings.com	713-594-5603	
	Brandon Nairn	TX - Northern	bnairn@lascofittings.com	972-333-1855	
	Burnley & Associates	DC, PA, DE, VA, MD, and WV	kerryb@burnleyassociates.com	610-842-7381	
	Fourmation Sales	MN/ND/SD/WI-West	dean@fourmationsales.com	763-262-4700	763-262-4740
	Gentile & Associates	CA, HI, NV, Mexico	tgentile@gentileandassociates.com	951-461-0942	951-461-1643
	John Hart	FL	jhart@lascofittings.com	772-595-7773	
	Marel Enterprises	NH, ME, CT, RI, NY	marelenterprisegmail.com	631-271-1718	631-427-8558
	Marsh & Moore	GA	jaustin@marshmoore.com	352-321-7499	904-827-8795
	Marshall-Rodeno Associated	CO, WY, MT, ID-SE, UT, NV-NE, NE, IA	dnaylor@marshallrodeno.com	303-575-6701	303-575-6706
	NSC Marketing Group Inc.	OK	nsc_tulsa@sbcglobal.net	918-627-5340	918-664-1408
	Pro Marketing, Inc.	NC/SC/TN-East	sales@promarketinginc.net	864-578-4334	864-578-4889
	Ryan Schuler	MO, KS, AR, IL, WI, TN - West & Middle, MS - North	rschuler@lascofittings.com	502-468-0384	
	Tim Morales & Associates, Inc.	AL	sales@timmorales.com	251-602-8333	251-602-8339
		VPC Sales	AZ, NV	chudson@vpcsales.com	661-257-3923