

BLOCK & BLEED VALVE

High Technology Valve & Fitting Series



INTEGRAL BLOCK & BLEED VALVES



CONTENTS

Introduction	2
Application installaltions	3
Specification	4-6
Ball valve type	
OS&Y Needle type	
Glove Needle Valve type	
Block & Bleed valve	7-15
Monoflange valve	16-19



INTRODUCTION

SUPERLOK's response to the demand for reduction in leakage paths has been the combination of primary and secondary valves into one compact unit. The combining of piping and instrument valves into a single unit has benefitted various markets.

SUPERLOK can offer the special combination of double block and bleed valve systems together with fittings, both being designed and produced by BMT. Choise of this combination results in the elimination of taper thread connections and the need for thread sealant.

APPLICATION & INSTALLATION

SOLUTIONS

SUPERLOK instrumentation products provided the ultimate suitable solutions for a integral block & bleed valve, which is consist of one piece forged body it provide many merits, featuring a choice of end connections, body style and

Conventional Installation <1>

- A welded flange, connected to a primary ANSI class isolating valve. The primary valve will be connected to a secondary instrument valve. A pressure gauge or transmitter will then be installed downstream of the instrument valve.

SUPERLOK BLOCK & BLEED Valve <2>

- A one-piece integral forging incorporating up 3 ball valve or mixture of ball and needle design.
- Improved safety : leak paths reduced by up to 60%
- Reduced costs : installation and component costs reduced by up to 70%
- Reduced weight : by up to 80%
- Reduced susceptibility to problems caused by vibration.

SUPERLOK Monoflange <3>

- More compact then SUPERLOK DBB valve, adding further space and weight saving possibilities.
- Improved safety : leak paths reduced by up to 60%, less susceptibility to vibration
- Reduced costs : installation and component costs saving up to 80%
- Reduced weight : up to 85%

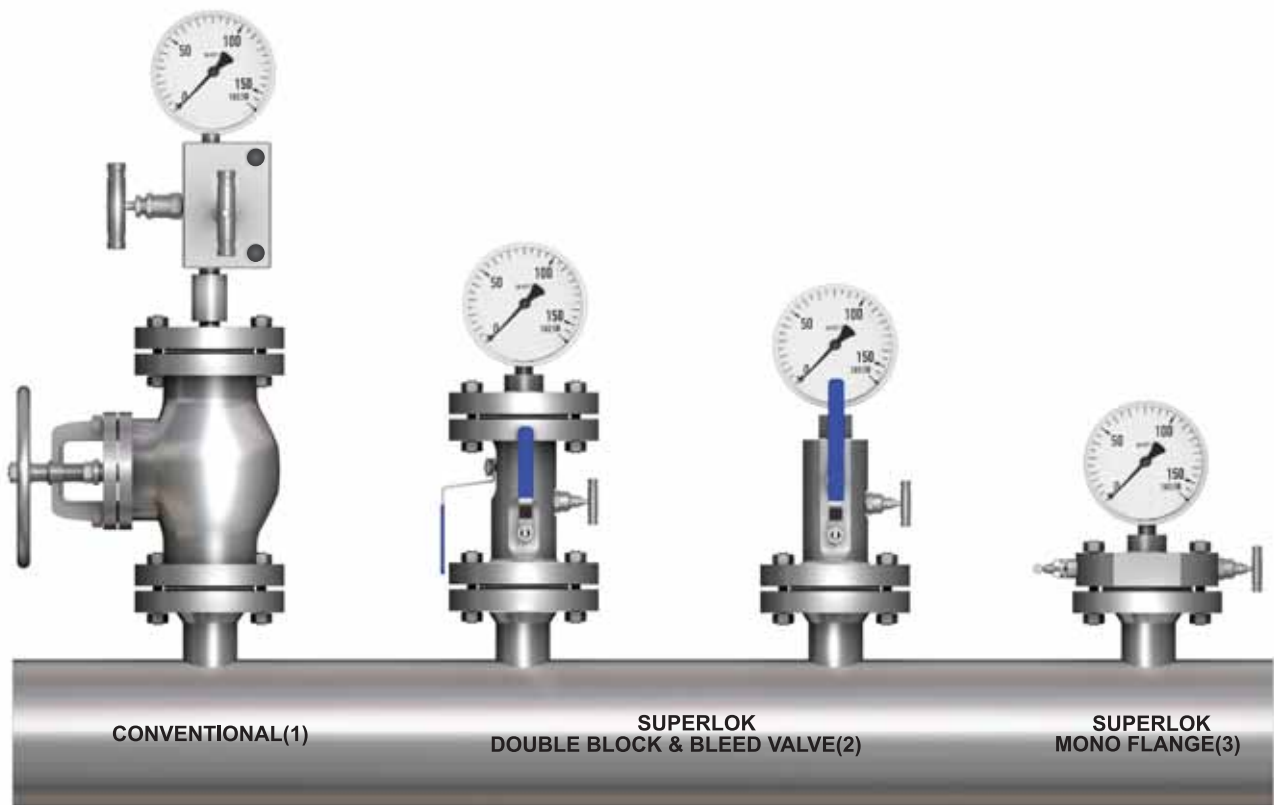

SPECIFICATION

Design codes

- ANSI / ASME B 16.34 - Designed to meet the pressure and temperature requirements
- ANSI / ASME B 16.5 - Flange dimensions
- ANSI / ASME B 1.20.1 - National pipe threads
- API 607 / BS 6755 - Fire safe designed

Ball Valve

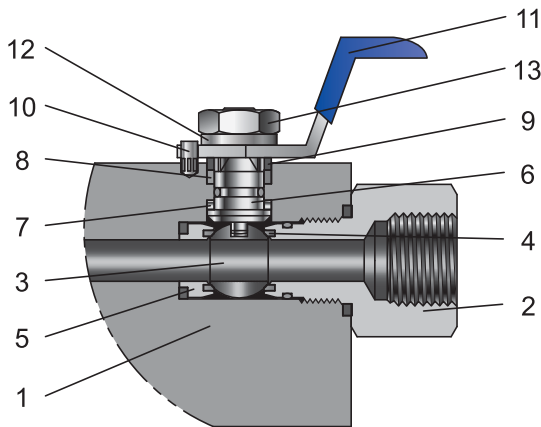

DESCRIPTION	BODY MATERIAL		
	STAINLESS STEEL	CARBON STEEL	DUPLEX STAINLESS STEEL
1 BODY	A182 F316	A350 LF2	A182 F51
2 OULET CONNECTOR	A182 F316	A350 LF2	A182 F51
3 BALL	A479 TP316		S31803
4 BALL SEAL	PTFE / R.PTFE / PEEK		
5 SEAT CAPSULE	A479 TP316		S31803
6 STEM	A479 TP316		S31803
7 LOWER STEM SEAL	PTFE		
8 UPPER STEM SEAL	GRAPHITE		
9 PACKING GLAND	A479 TP316		S31803
10 STOP PIN	SS 316		S31803
11 HANDLE	SS 316		
12 STEM WASHER	SS 316		
13 STEM NUT	A194 8M		

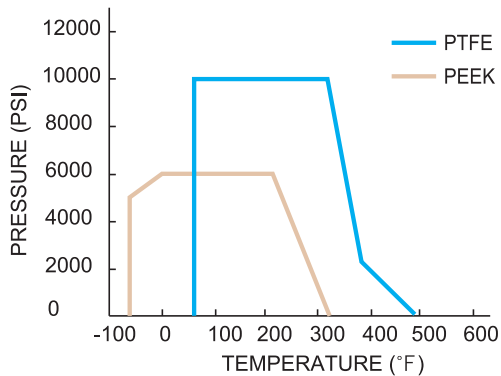

- 316 Stainless steel construction.
- Maximum cold working pressure rating 6,000 psig(414 bar) with PTFE seats.
- Temperature rating PTFE seats -54°C to 204°C (-65°F to 400°F)
- Maximum cold working pressure rating 10,000 psig(689 barg) with PEEK seats.
- Temperature rating PEEK seats -54°C to 232°C (-65°F to 450°F)

Features

- Two piece body design - minimize leakage paths.
- Designed to comply with requirements of ANSI/ASME B16.34.
- Bi-directional.
- Ball seats choice of seat materials : PTFE(virgin or filled)PVDF , NYLON or PEEK.
- Bubble tight shutoff.
- Floating ball principal with dynamic response seats featuring inherent self relief.
- Anti blowout stem.
- Integral compression ends available eliminating taper threads and thread sealants.
- Low torque operation.
- Connector thread environmentally sealed.
- Anti static design as standard.
- Firesafe designed to meet BS 6755 Part2 / API 607,(optional).

Outside screw and yoke(OS&Y) needle valve

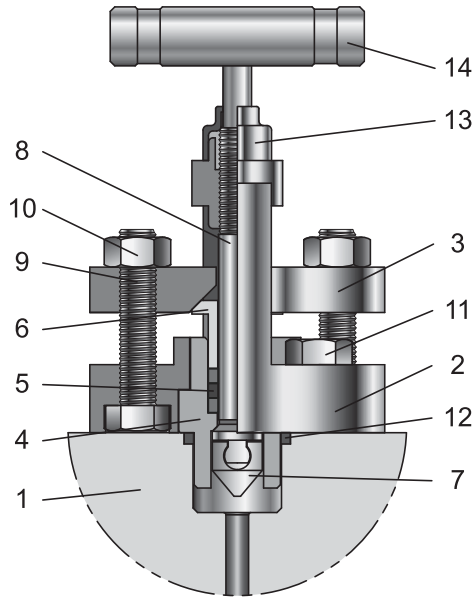

DESCRIPTION	BODY MATERIAL		
	STAINLESS STEEL	CARBON STEEL	DUPLEX STAINLESS STEEL
1 BODY	A182 F316	A350 LF2	A182 F51
2 OS & Y BONNET	A351 CF8M	A352 LCC	A182 F51
3 GLAND FLANGE	A351 CF8M	A352 LCC	A182 F51
4 INSERT	A479 TP316		S31803
5 PACKING	GRAPHITE		
6 BUSHING	A479 TP316		S31803
7 VEE TIP	SS630 + Hard Cr		
8 STEM	A479 TP316		S31803
9 FLANGE BOLT	A193 B8M	A320 L7M	A453 Gr.660
10 FLANGE NUT	A194 8M	A194 Gr.7	
11 BONNET BOLT	A193 B8M	A320 L7M	
12 BONNET SEAL	GRAPHITE		
13 DUST CAP	NYLON		
14 BAR HANDLE	A276 TP316		S31803

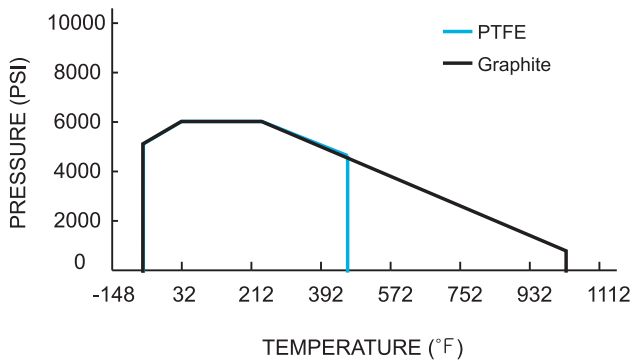

- 316 Stainless steel construction.
- Maximum cold working pressure rating 10,000 psig(690 bar).
- Temperature rating -54°C to 538°C (-65°F to 1000°F).

Features

- Externally adjustable gland.
- PTFE or Graphite packing for bubble tight sealing.
- Self centering crimped needle tip for bubble tight shut off and repeatability.
- All componets stainless steel .
- Firesafe certified to BS6755 part 2/API 607.
- Flange gasket seal ensures a bubble-tight between body and yoke.
- Back seat design provides secondary stem sealing and prevents stem blow out.
- Rolled stem operating threads.
- Independent stem thread bush with maximum female thread interface.
- Colour coded close contact dust cap and function label for easy indentification.

Glove style needle valve

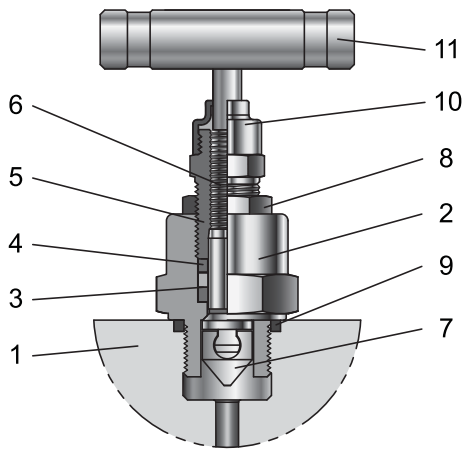

DESCRIPTION	BODY MATERIAL		
	STAINLESS STEEL	CARBON STEEL	DUPLEX STAINLESS STEEL
1 BODY	SS 316	A350 LF2	A182 F51
2 BONNET	SS 316	A350 LF2	A182 F51
3 PACKING	GRAPHITE		
4 PACKING GLAND	A479 TP316		S31803
5 PACKING BOLT	SS 316	A350 LF2	S31803
6 STEM	A479 TP316		S31803
7 VEE TIP	SS630 + Hard Cr		
8 LOCK NUT	SS 316	A350 LF2	S31803
9 BONNET SEAL	GRAPHITE		
10 DUST CAP	NYLON		
11 BAR HANDLE	A276 TP316		S31803

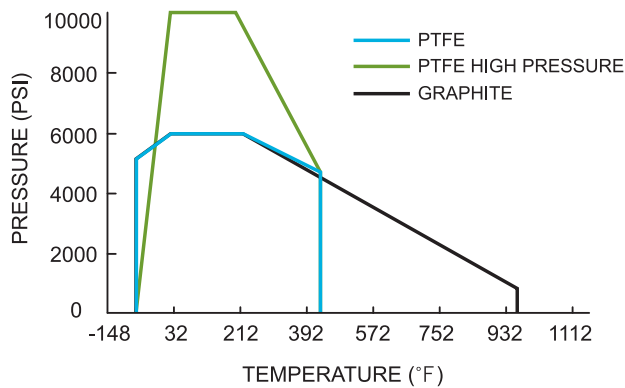

- 316 Stainless steel construction.
- Maximum cold working pressure rating 10,000 psig(690 bar).
- Temperature rating -54°C to 538°C (-65°F to 1000°F).

Features

- Rolled stem operating threads for low torque operation.
- Gland packing in PTFE or Graphite for bubble tight sealing.
- Colour coded close contact dust cap and function label for easy identification.
- Self centering crimped needle tip for bubble tight seat sealing.
- Close contact dust cap for operating thread protection.
- Packing bolt with easy access.
- Lock nut for vibration protection.

Block & Bleed valve

Features

- ANSI B16.5 flanged inlet connections 1/2" to 3" sizes.
- Class 150 rated to class 2500 rated.
- 1/2"-14 to 1"-11.5 NPT(female) standard outlet (depending on bore size).
- 1/2" NPT(female) standard vent.
- Standard materials of connection: Stainless steel ASTM A182 F316/F316L, Carbon steel ASTM A350 LF2/A105, Duplex ASTM A182 F51.
- Optional materials on request.
 Stainless steel ASTM A182 F316/F316L.
 Carbon steel ASTM A350 LF2/A105.
 Duplex ASTM A182 F51.
- Raised face and ring type joint flange face styles.
- One-piece forged construction flange as standard.
- Fire safe designed (and tested) to meet BS 6755 Part 2/API 607.
- 304 stainless steel handles and trim as standard to reduce the risk of corrosion.
- Designed to meet the pressure and temperature requirements of ASME/ANSI B16.34/B16.5.
- Pressure boundary designs calculated to ASME VIII Div 1 and verified by testing.
- Heat code traceable material to EN 10204.3.1.
- Bubble tight shut off.
- Locking and anti tamper devices for all valve types available option.
- Positive lever stop.
- User preferred handles.
- Permanent affixed reference label.



DB-S1/S2 SERIES

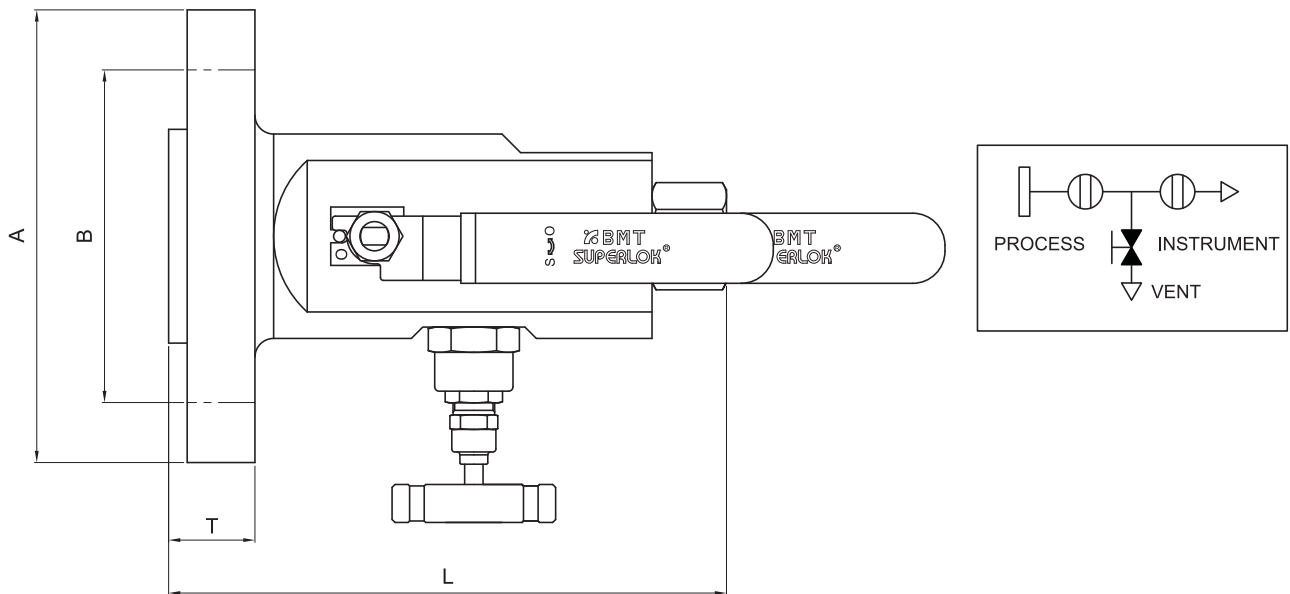

Dimensions

(10mm BORE)

SIZE (inch)	RATING (lb)	DIMENSION (mm)				
		DB - S1 L (RF)	A	B	T	
1/2 (DN15)	150	170	89	60.3	11.2	
	300		96		66.7	14.2
	600	20.6				
	900/1500	186		121		82.5
	2500		134	88.9	36.6	
3/4 DN(20)	150	175	99	69.8	12.7	
	300		118		82.5	15.7
	600					22.1
	900/1500	179	130	88.9	31.8	
	2500	186	140	95.2	38.2	
1 (DN25)	150	170	108	79.4	14.2	
	300		124		88.9	17.5
	600	23.9				
	900/1500	186		150		101.6
	2500		159	108.0	41.5	
1-1/2 (DN40)	150	170	127	98.4	17.5	
	300	179	156	114.3	20.6	
	600				27.0	
	900/1500	186	178	124.0	38.2	
	2500	200	203	146.1	50.9	
2 (DN50)	150	179	152	120.6	22.4	
	300		165		127.0	24.0
	600	186		30.4		
	900/1500	200		216		165.1
	2500	208	235	171.5	57.2	

*Dimensions are for reference only and are subject to change.

Dimensions

(14mm BORE)

SIZE (inch)	RATING (lb)	DIMENSION (mm)			
		DB - S1	A	B	T
		L (RF)			
3/4 DN(20)	150	208	99	69.8	12.7
	300		118	82.5	15.7
	600	22.1			
	900/1500	218			130
	2500	224	140	95.2	38.2
1 (DN25)	150	208	108	79.4	14.2
	300		124	88.9	17.5
	600	23.9			
	900/1500	224			150
	2500	227	159	108.0	41.5
1-1/2 (DN40)	150	208	127	98.4	17.5
	300		156	114.3	20.6
	600	27.0			
	900/1500	224			178
	2500	238	203	146.1	50.9
2 (DN50)	150	218	152	120.6	22.4
	300		165	127.0	24.0
	600	30.4			
	900/1500	238			216
	2500	246	235	171.5	57.2

*Dimensions are for reference only and are subject to change.

(20mm BORE)

SIZE (inch)	RATING (lb)	DIMENSION (mm)			
		DB - S1	A	B	T
		L (RF)			
1 (DN25)	150	235	108	79.4	14.2
	300		124	88.9	17.5
	600	23.9			
	900/1500	251			150
	2500	251	159	108.0	41.5
1-1/2 (DN40)	150	235	127	98.4	17.5
	300		156	114.3	20.6
	600	27.0			
	900/1500	251			178
	2500	265	203	146.1	50.9
2 (DN50)	150	244	152	120.6	22.4
	300		165	127.0	24.0
	600	30.4			
	900/1500	265			216
	2500	273	235	171.5	57.2

*Dimensions are for reference only and are subject to change.

DB-D1/D2 SERIES

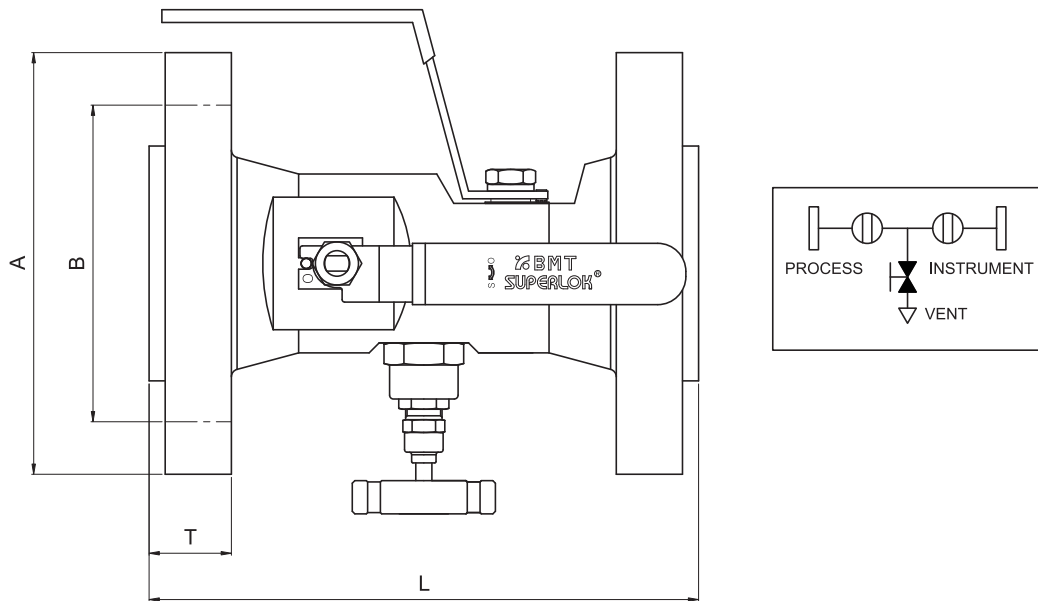

Dimensions

(10mm BORE)

SIZE (inch)	RATING (lb)	DIMENSION (mm)			
		DB - S1 L (RF)	A	B	T
1/2 (DN15)	150	235	89	60.3	11.2
	300		96	66.7	14.2
	600				20.6
	900/1500	254	121	82.5	28.8
	2500	267	134	88.9	36.6
3/4 DN(20)	150	235	99	69.8	12.7
	300		118	82.5	15.7
	600				22.1
	900/1500	254	130	88.9	31.8
	2500	267	140	95.2	38.2
1 (DN25)	150	235	108	79.4	14.2
	300		124	88.9	17.5
	600				23.9
	900/1500	267	150	101.6	34.8
	2500	267	159	108.0	41.5
1-1/2 (DN40)	150	235	127	98.4	17.5
	300	254	156	114.3	20.6
	600				27.0
	900/1500				267
	2500	314	203	146.1	50.9
2 (DN50)	150	254	152	120.6	22.4
	300		165	127.0	24.0
	600				30.4
	900/1500	314	216	165.1	44.5
	2500	334	235	171.5	57.2

*Dimensions are for reference only and are subject to change.

Dimensions

(14mm BORE)

SIZE (inch)	RATING (lb)	DIMENSION (mm)			
		DB - S1	A	B	T
		L (RF)			
3/4 DN(20)	150	235	99	69.8	12.7
	300		118	82.5	15.7
	600	22.1			
	900/1500	254	130	88.9	31.8
	2500	267	140	95.2	38.2
1 (DN25)	150	235	108	79.4	14.2
	300		124	88.9	17.5
	600	23.9			
	900/1500	267	150	101.6	34.8
	2500	273	159	108.0	41.5
1-1/2 (DN40)	150	235	127	98.4	17.5
	300		156	114.3	20.6
	600	27.0			
	900/1500	267	178	124.0	38.2
	2500	334	203	146.1	50.9
2 (DN50)	150	254	152	120.6	22.4
	300		165	127.0	24.0
	600	30.4			
	900/1500	334	216	165.1	44.5
	2500		235	171.5	57.2

*Dimensions are for reference only and are subject to change.

(20mm BORE)

SIZE (inch)	RATING (lb)	DIMENSION (mm)			
		DB - S1	A	B	T
		L (RF)			
1 (DN25)	150	235	108	79.4	14.2
	300		124	88.9	17.5
	600	23.9			
	900/1500	267	150	101.6	34.8
	2500	273	159	108.0	41.5
1-1/2 (DN40)	150	235	127	98.4	17.5
	300		156	114.3	20.6
	600	27.0			
	900/1500	268	178	124.0	38.2
	2500	334	203	146.1	50.9
2 (DN50)	150	254	152	120.6	22.4
	300		165	127.0	24.0
	600	30.4			
	900/1500	334	216	165.1	44.5
	2500		235	171.5	57.2

*Dimensions are for reference only and are subject to change.

Dimensions

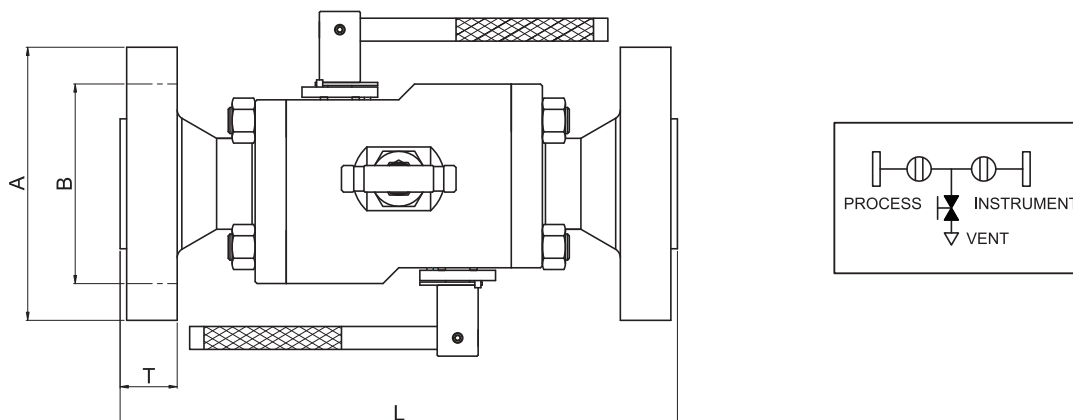

(REDUCER BORE)

SIZE (inch)	BORE (mm)	RATING (lb)	DIMENSION (mm)				A	T
			RF FLANGE		RTJ FLANGE			
			L	T	L	T		
1-1/2 (DN40)	25.4	150	279	19.5	292	25.9	298	132
		300	285	22.6	-	-		
		600	301	30.8	301	30.8		
		900/1500	370	40.2	370	40.2		
		2500	396	52.9	399	54.4		
2 (DN50)	38.1	150	364	21.1	377	27.5	325	147
		300	372	27.9	-	-		
		600	390	33.8	393	35.3		
		900/1500	415	46.5	418	48.0		
		2500	475	59.2	478	60.7		
3 (DN75)	50.8	150	400	25.9	413	32.3	452	170
		300	410	30.9	-	-		
		600	428	40.2	431	41.7		
		900/1500	441	46.5	444	48.0		
		2500	500	56.2	503	57.7		

*Dimensions are for reference only and are subject to change.

(FULL BORE)

SIZE (inch)	BORE (mm)	RATING (lb)	DIMENSION (mm)				A	T
			RF FLANGE		RTJ FLANGE			
			L	T	L	T		
1 (DN25)	25.4	150	272	16.2	285	22.6	298	132
		300	279	19.5	-	-		
		600	292	25.9	292	25.9		
		900/1500	364	36.8	364	36.8		
		2500	377	43.5	377	43.5		
1-1/2 (DN40)	38.1	150	361	19.5	374	25.9	325	147
		300	367	22.6	-	-		
		600	384	30.8	384	30.8		
		900/1500	402	40.2	402	40.2		
		2500	463	52.9	466	54.4		
2 (DN50)	50.8	150	390	21.1	403	27.5	452	170
		300	398	24.9	-	-		
		600	416	33.8	419	35.3		
		900/1500	481	46.5	484	48.0		

*Dimensions are for reference only and are subject to change.

SAMPLING VALVE

This manifold range is designed to replace conventional multiple-valve installations where sampling of the process stream is required. This design has been developed to remove a sample directly from the process stream at full system pressure.

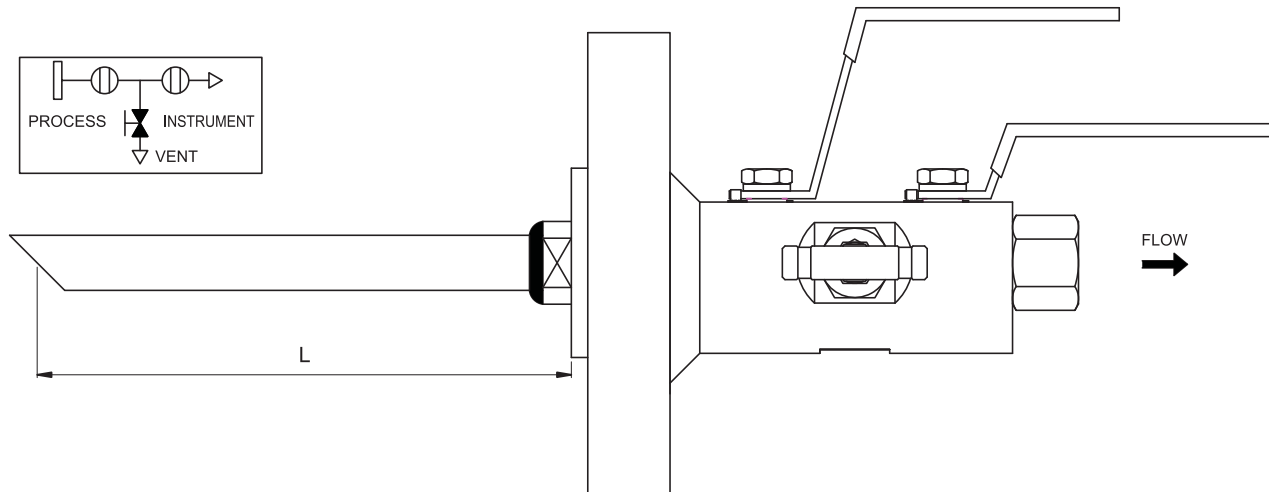

Sampling probe

The probe length must be specified from the raised face to the end of the probe in mm , to the nearest mm. Probes are supplied to suit the insertion length required by the pipeline and thus must be specified by the customer

CHEMICAL INJECTION VALVE

This manifold range is designed to replace conventional multiple-valve installations where injection into the process stream is required. This design has been developed to inject directly into the process stream at full system pressure.

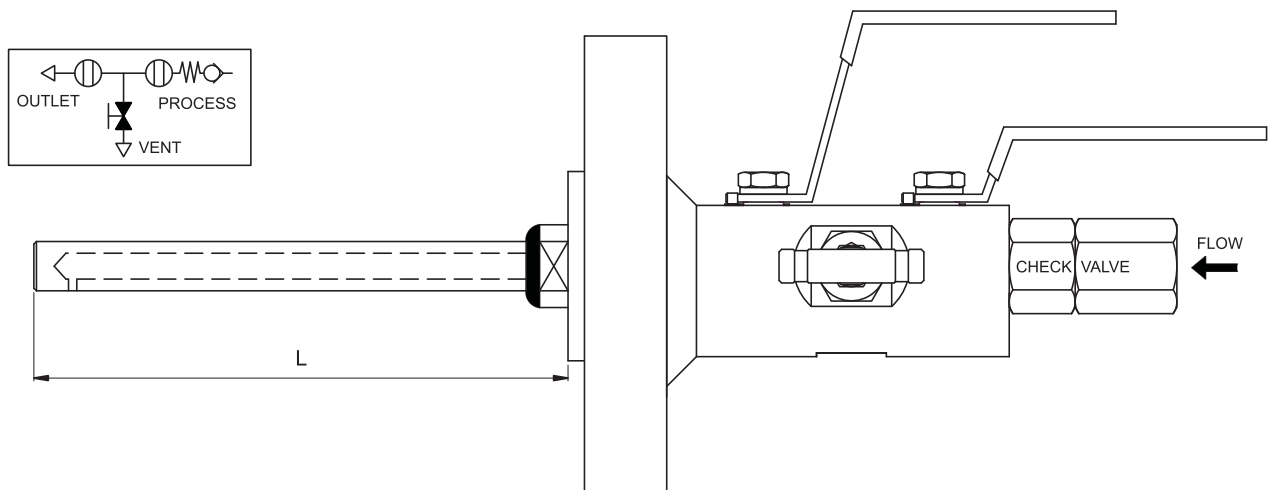

Injection quill

The probe length must be specified from the raised face to the end of the probe in mm . Probes length shall be decided in consideration of injection insert length in the pipeline and customer's request.

Non return check valve

This poppet type spring return valve has a viton soft seal(SUPERLOK standard)

FUGITIVE EMISSION

ISO 15848 parts 1&2 (defining a classification system and qualification procedures, and production acceptance test of industrial valves, respectively) specify new ultra low standards for emissions. This standard is becoming the requirement for oil and gas and petrochemical organizations worldwide. The standard was originally created for process valves and control valves but is now being applied to Instrument valves which include primary isolation valves, especially on environmentally sensitive projects. Meeting these low levels is a challenge, which BMT Instrument has solved with the new ball and needle valve designs used in these DBB valves and mono flanges. These designs meet the highest class 'A' level over the temperature range -29°C to +180°C, alongside the standard instrumentation manifold pressure ranges. Production testing and certification is available upon request. Please specify sample quantity required for production testing with your order.

Valve Specification

- Tightness class A $> 1 \times 10^{-6}$ mg.s-1.m-1.
- Maximum cold working pressure rating 6,000 psig.
- Temperature rating -29°C to 180°C (-20°F to 356°F)
- ISO15848-1 prototype tested using global helium vacuum method.
- Performance class -ISO FE AH-CO1-SSA1-t(RT, 180°C)-ANSI2500-ISO 15848-1

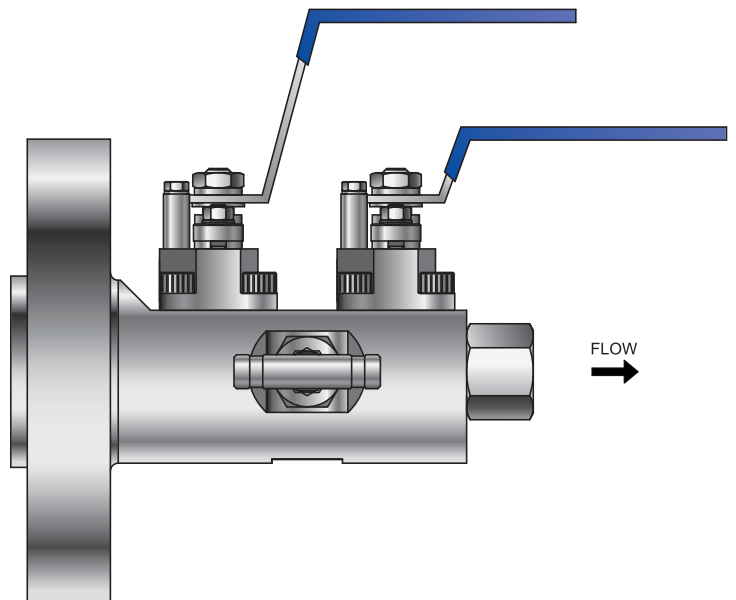
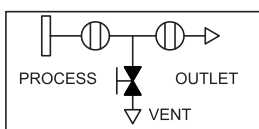
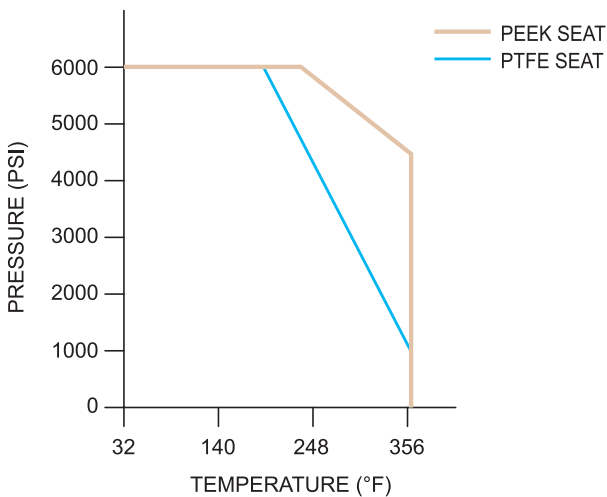

The ISO 15848 standard effectively sets a requirement for zero emissions for processes involving volatile air pollutants and hazardous fluids. This design has been developed to minimise fugitive emissions.

Monoflange valve

Features

- ANSI B16.5 flanged inlet connections 1/2" to 2" sizes.
- Class 150 rated to class 2500 rated.
- 1/2"-14 NPT(female) standard outlet.
- 1/4"-18 NPT(female) standard vent.
- Standard materials of connection: Stainless steel
- Optional materials on request.
 Stainless steel ASTM A182 F316/F316L
 Carbon steel ASTM A350 LF2/A105
 Duplex ASTM A182 F51, Super Duplex
 Monel, Hastelloy, 6Mo, Incoloy.
- Combined needle and OS & Y valves available.
- Raised face and ring type joint flange face styles.
- One-piece forged construction flange as standard.
- Fire safe designed to meet BS 6755 Part 2 / API 607.
 (As option)
- Pressure boundary designs calculated to ASME VIII Div 1 and verified by testing.
- Heat code traceable material to EN 10204.3.1.
- Bubble tight shut off valve seats 17-4 PH tips standard.
- Optional PEEK tips available.
- Colour coded functional valves.
- Locking and anti tamper devices for all valve types available. (as option)
- Permanent marked body with full order and specification details.



MF-V1 Series

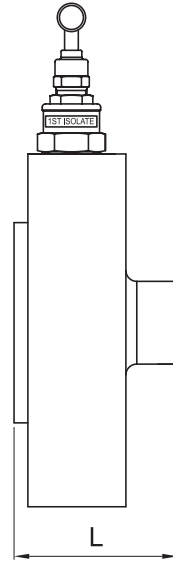
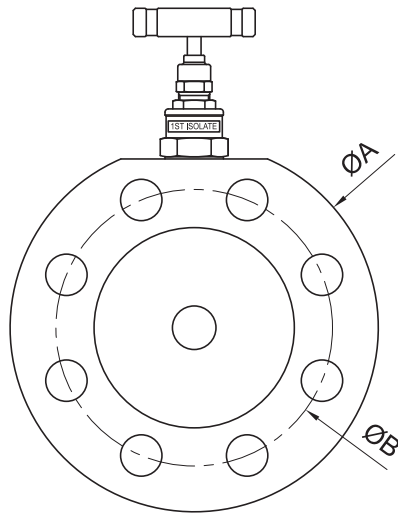
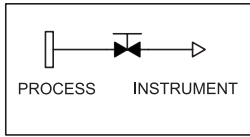

MF-V2 Series

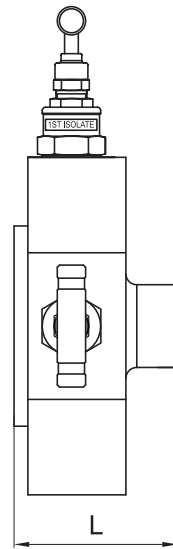
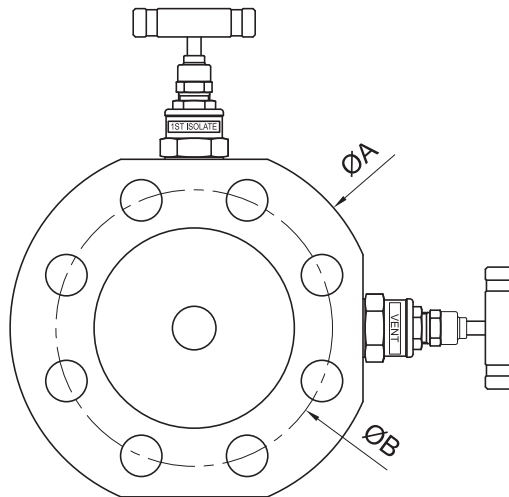
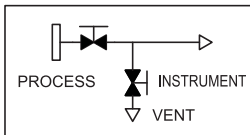

MF-V3 Series

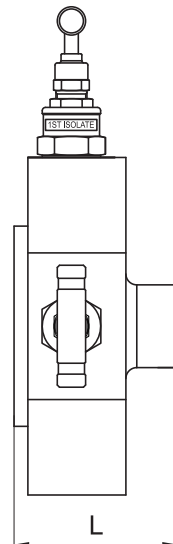
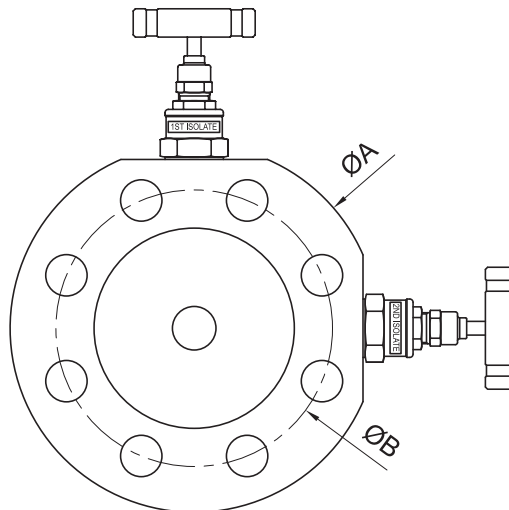
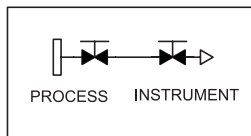

MF-V4 SERIES

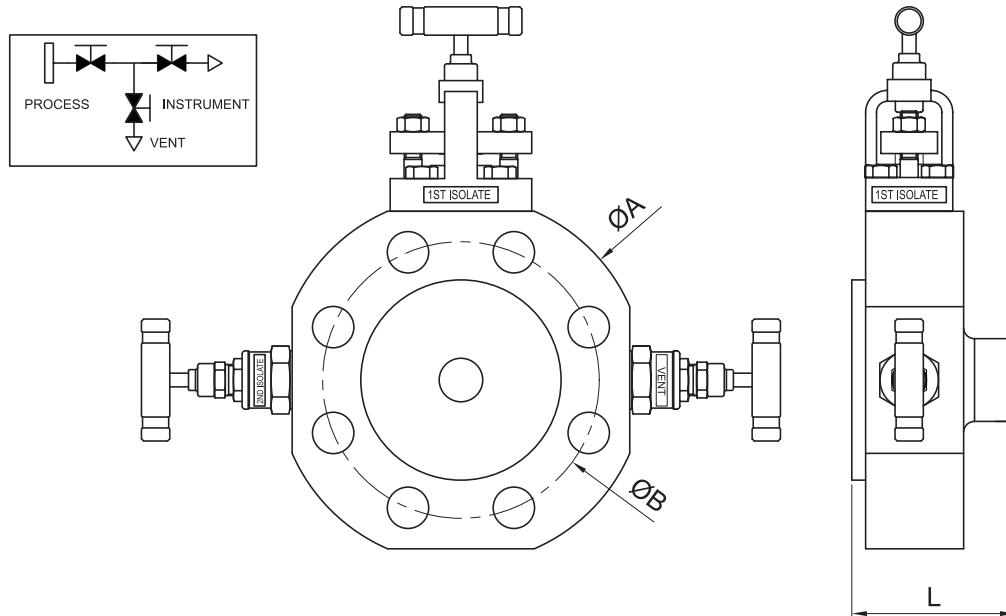

Dimensions

SIZE (inch)	RATING (lb)	DIMENSION (mm)			
		L(RF)	L(RTJ)	A	B
1/2 (DN15)	150	64	-	89	60.3
	300		64	96	66.7
	600	121		82.5	
	900/1500	134		88.9	
	2500	68	-	99	69.8
3/4 DN(20)	150	64	-	99	69.8
	300	68	68	118	82.5
	600			130	88.9
	900/1500	73	73	140	95.2
	2500	73	73	159	108.0
1 (DN25)	150	64	68	108	79.4
	300	68		124	88.9
	600	73	73	150	101.6
	900/1500			159	108.0
	2500	73	73	159	108.0
1-1/2 (DN40)	150	64	68	127	98.4
	300	69	69	156	114.3
	600	73	73		
	900/1500			73	73
	2500	82	84	203	146.1
2 (DN50)	150	69	73	152	120.6
	300		75	165	127.0
	600	73			
	900/1500	82	84	216	165.1

*Dimensions are for reference only and are subject to change.

Ordering Information

Example) : **LOK-MF - V11 - F8R1N8-SS-AT**

1
2
3
4
2
3
5
6

1. Valve Series

SERIES		1st ISOLATE	2st ISOLATE	VENT	
IDENTIFY					
MF	V1	1	NEEDLE	-	
		2	OS & Y		
	V2	1	NEEDLE	-	
		2	OS & Y		
	V3	1	NEEDLE	NEEDLE	
		2	OS & Y		
	V4	1	NEEDLE	NEEDLE	NEEDLE
		2		OS & Y	
		3	OS & Y	NEEDLE	
		4		OS & Y	

2. Connection type

F - RAISED FACE FLANGE
 J - RING TYPE JOINT FLANGE
 N - NPT
 BW - BUTT WELD
 SW - SOCKET WELD

3. Connection size (inch)

4 - 1/4" 16 - 1"
 6 - 3/8" 24 - 1-1/2"
 8 - 1/2" 32 - 2"
 12 - 3/4"

4. Flange rating (class)

R1 - 150 R4 - 900
 R2 - 300 R5 - 1500
 R3 - 600 R6 - 2500

5. Body Material

SS(NIL) - ASTM A 182 F316
 105 - ASTM A105
 LF2 - ASTM A350 LF2
 F51 - ASTM A182 F51
 M - MONEL ALLOY 400

6. Option

BB - BOLTED BONNET
 FE - FUGITIVE EMISSION
 LD - LOCKING DEVICE
 AT - ANTI TAMPER KEY
 FS - FIRE SAFETY

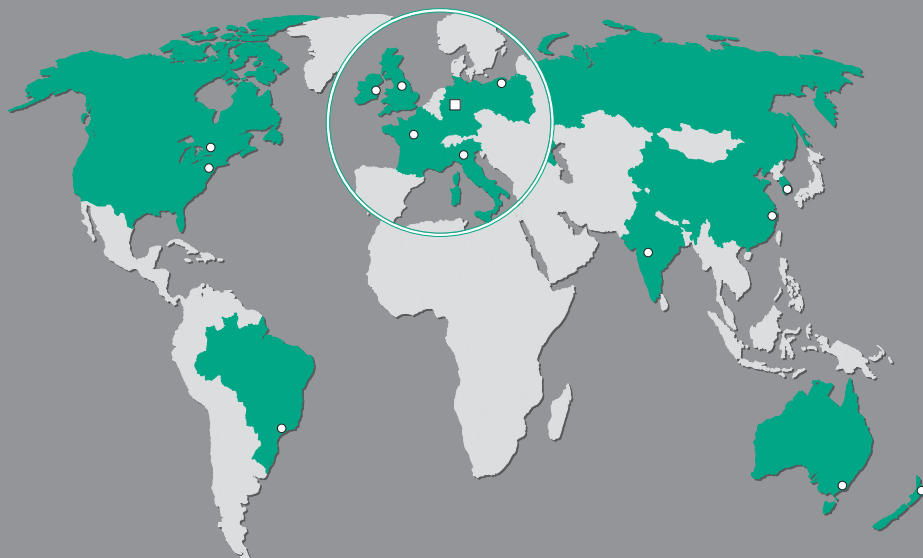

AUSTRALIA

STAUFF Corporation Pty. Ltd.
P. O. Box 227
Unanderra, NSW, 2526
24-26 Doyle Avenue
Unanderra, Wollongong, NSW, 2526
Tel.: +61 2 4271 18 77
Fax: +61 2 4271 84 32
sales@stauff.com.au

BRAZIL

STAUFF Brasil Ltda.
Avenida Gupê 10767
Galpão 2 - Bloco A
Barueri - São Paulo
CEP 06422-120
Tel.: +55 11 47 72 72 00
Fax: +55 11 47 72 72 10
stauff@stauffbrasil.com

CANADA

STAUFF Canada Ltd.
866 Milner Avenue
Scarborough
Ontario M1B 5N7
Tel.: +1 416 282 46 08
Fax: +1 416 282 30 39
sales@stauffcanada.com

CHINA

STAUFF International Trading
(Shanghai) Co., Ltd.
No. 41-42, Lane 369, Chuang Ye Road
Jushuo Industrial Zone, Kang Qiao
Shanghai, 201319
Tel.: +86 21 68 18 70 00
Fax: +86 21 68 18 71 36
info@stauff.com.cn

FRANCE

STAUFF S.A.S.
230, Avenue du Grain d'Or
Z.I. de Vineuil - Blois Sud
41354 Vineuil-cedex
Tel.: +33 2 54 50 55 50
Fax: +33 2 54 42 29 19
direction@stauffsa.com

GERMANY

WALTER STAUFFENBERG GmbH & Co. KG

P. O. Box 1745
D-58777 Werdohl
Im Ehrenfeld 4
D-58791 Werdohl
Tel.: +49 23 92 916-0
Fax: +49 23 92 2505
filtrationtechnology@stauff.com
www.stauff.com

INDIA

STAUFF India Pvt. Ltd.
Gat. No. 2340
Pune Nagar Road, Wagholi
Pune, 412207
Tel.: +91 20 6620 2473
Fax: +91 20 2705 1567
sales@stauffindia.com

ITALY

STAUFF Italia s.r.l.
Viale Nuova Valassina 78
angolo Via Baragiola sn
20033 Desio (MI)
Tel.: +39 0362 63 80 70
Fax: +39 0362 63 80 69
sales@stauff.it

IRELAND

STAUFF Ireland Ltd.
Unit B3
Weatherwell Business Park
Clondalkin
Dublin 22
Tel.: +353 1457 4936
Fax: +353 1467 0687
sales@stauff.ie

KOREA

STAUFF Korea Ltd.
1500-12, Dadae-Dong
Saha-Ku
Pusan, 604-826
Tel.: +82 51 266 6666
Fax.: +82 51 266 8866
info@stauff.co.kr

NEW ZEALAND

STAUFF Corporation (NZ) Ltd.
P. O. Box 58517
Greenmount, Auckland
Unit D, 103 Harris Road
East Tamaki, Auckland
Tel.: + 64 9 271 48 12
Fax: + 64 9 271 48 32
info@stauff.co.nz

POLAND

STAUFF Polska Sp. z o.o.
Miszewko 43 A
80-297 Banino
Tel.: +48 58 660 11 60
Fax: +48 58 629 79 52
sales@stauff.pl

RUSSIAN FEDERATION

STAUFF LLC
Office 205, Building 7
Scharikopodschipnikovskaya 11
Moscow, 115088
Tel.: +7 495 987 36 29
+7 495 223 89 61
Fax: +7 495 679 90 48
sales@stauff.ru

UNITED KINGDOM

STAUFF UK
Unit B3
500, Carlisle Street East
Off Downgate Drive
Sheffield, S4 8BS
Tel.: +44 114 251 85 18
Fax: +44 114 251 85 19
sales@stauff.co.uk

UNITED STATES

STAUFF Corporation
7 Wm. Demarest Place
Waldwick, 07463-1542
New Jersey
Tel.: +1 201 444 78 00
Fax: +1 201 444 78 52
sales@stauffusa.com

Globally available through
wholly-owned branches and
distributors in all industrial
countries.

STAUFF